

# SERVICE MANUAL

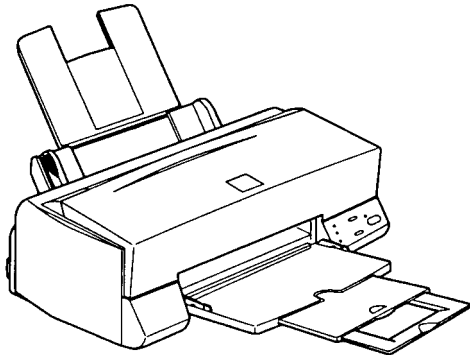

Color ink jet printer

**EPSON Stylus Color 440/640/740**

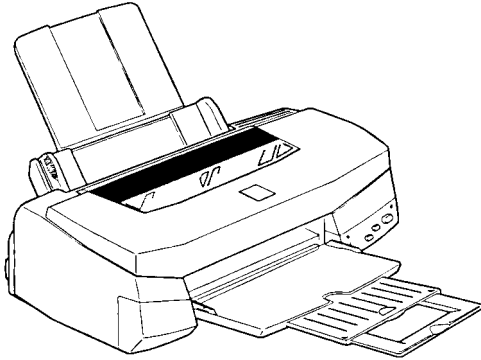

**EPSON®**

## Notice:

- All rights reserved. No part of this manual may be reproduced, stored in a retrieval system, or transmitted in any form or by any means, electronic, mechanical, photocopying, recording, or otherwise, without the prior written permission of SEIKO EPSON CORPORATION.
- The contents of this manual are subject to change without notice.
- All effort have been made to ensure the accuracy of the contents of this manual. However, should any errors be detected, SEIKO EPSON would greatly appreciate being informed of them.
- The above notwithstanding SEIKO EPSON CORPORATION can assume no responsibility for any errors in this manual or the consequences thereof.

EPSON is a registered trademark of SEIKO EPSON CORPORATION.

General Notice: Other product names used herein are for identification purpose only and may be trademarks or registered trademarks of their respective owners. EPSON disclaims any and all rights in those marks.

Copyright © 1996 SEIKO EPSON CORPORATION. Printed in Japan.

# PRECAUTIONS

Precautionary notations throughout the text are categorized relative to 1) Personal injury and 2) damage to equipment.

**DANGER** Signals a precaution which, if ignored, could result in serious or fatal personal injury. Great caution should be exercised in performing procedures preceded by DANGER Headings.

**WARNING** Signals a precaution which, if ignored, could result in damage to equipment.

The precautionary measures itemized below should always be observed when performing repair/maintenance procedures.

## **DANGER**

1. ALWAYS DISCONNECT THE PRODUCT FROM THE POWER SOURCE AND PERIPHERAL DEVICES PERFORMING ANY MAINTENANCE OR REPAIR PROCEDURES.
2. NOWORK SHOULD BE PERFORMED ON THE UNIT BY PERSONS UNFAMILIER WITH BASIC SAFETY MEASURES AS DICTATED FOR ALL ELECTRONICS TECHNICIANS IN THEIR LINE OF WORK.
3. WHEN PERFORMING TESTING AS DICTATED WITHIN THIS MANUAL, DO NOT CONNECT THE UNIT TO A POWER SOURCE UNTIL INSTRUCTED TO DO SO. WHEN THE POWER SUPPLY CABLE MUST BE CONNECTED, USE EXTREME CAUTION IN WORKING ON POWER SUPPLY AND OTHER ELECTRONIC COMPONENTS.

## **WARNING**

1. REPAIRS ON EPSON PRODUCT SHOULD BE PERFORMED ONLY BY AN EPSON CERTIFIED REPAIR TECHNICIAN.
2. MAKE CERTAIN THAT THE SOURCE VOLTAGES IS THE SAME AS THE RATED VOLTAGE, LISTED ON THE SERIAL NUMBER/RATING PLATE. IF THE EPSON PRODUCT HAS A PRIMARY AC RATING DIFFERENT FROM AVAILABLE POWER SOURCE, DO NOT CONNECT IT TO THE POWER SOURCE.
3. ALWAYS VERIFY THAT THE EPSON PRODUCT HAS BEEN DISCONNECTED FROM THE POWER SOURCE BEFORE REMOVING OR REPLACING PRINTED CIRCUIT BOARDS AND/OR INDIVIDUAL CHIPS.
4. IN ORDER TO PROTECT SENSITIVE MICROPROCESSORS AND CIRCUITRY, USE STATIC DISCHARGE EQUIPMENT, SUCH AS ANTI-STATIC WRIST STRAPS, WHEN ACCESSING INTERNAL COMPONENTS.
5. REPLACE MALFUNCTIONING COMPONENTS ONLY WITH THOSE COMPONENTS BY THE MANUFACTURE; INTRODUCTION OF SECOND-SOURCE ICs OR OTHER NONAPPROVED COMPONENTS MAY DAMAGE THE PRODUCT AND VOID ANY APPLICABLE

# PREFACE

This manual describes basic functions, theory of electrical and mechanical operations, maintenance and repair procedures of Stylus Color 440/640/740. The instructions and procedures included herein are intended for the experienced repair technicians, and attention should be given to the precautions on the preceding page. The chapters are organized as follows:

## **CHAPTER 1. PRODUCT DESCRIPTIONS**

*Provides a general overview and specifications of the product.*

## **CHAPTER 2. OPERATING PRINCIPLES**

*Describes the theory of electrical and mechanical operations of the product.*

## **CHAPTER 3. TROUBLESHOOTING**

*Provides the step-by-step procedures for troubleshooting.*

## **CHAPTER 4. DISASSEMBLY AND ASSEMBLY**

*Describes the step-by-step procedures for disassembling and assembling the product.*

## **CHAPTER 5. ADJUSTMENTS**

*Provides Epson-approved methods for adjustment.*

## **CHAPTER 6. MAINTENANCE**

*Provides preventive maintenance procedures and the lists of Epson-approved lubricants and adhesives required for servicing the product.*

## **APPENDIX**

*Provides the following additional information for reference:*

- *Connector pin assignments*
- *Electric circuit boards components layout*
- *Exploded diagram*
- *Electrical circuit boards schematics*

## REVISION STATUS

Rev.	Date	Page(s)	Contents
A	1998/07/15	All	First Release
B	1998/09/30	Page 188 Pages 195 to 212	The exploded diagrams and part list for the Stylus Color 740 has been added.

## ***Product Description***

---

Features .....	9
Specifications .....	11
Printing Specification .....	11
Paper Specification .....	15
Printing Area.....	17
Ink Cartridge Specifications.....	20
Environmental Condition .....	22
Electric Specification .....	23
Reliability .....	23
Safety Approvals .....	23
Acoustic Noise.....	24
CE Marking.....	24
Input Data Buffer .....	24
Interface.....	25
Parallel Interface (Forward Channel) .....	25
Parallel Interface (Reverse Channel) .....	27
Serial Interface (for Stylus Color 640, 740) .....	31
Control Panel.....	32
Indicators (LEDs).....	32
Panel Functions.....	33
Printer Condition and Panel Status .....	34
Error Status .....	35
Ink Out.....	35
Paper Out.....	35
Paper Jam.....	35
No Ink-Cartridge .....	36
Maintenance Request .....	36
Fatal Errors.....	36
Printer Initialization .....	37
Initialization Settings.....	37
Main Components .....	38
Printer Mechanism .....	38
C206 Main-B Board (Stylus Color 440) .....	39
C256 Main Board (Stylus Color 640).....	39
C257 Main Board (Stylus Color 740).....	40

Power Supply Board	
C206 PSB/PSE (Stylus Color 440, 640)	
C257 PSB/PSE (Stylus Color 740).....	40
C206 PNL Board (Stylus Color 440, 640).....	41
C209 PNL Board (Stylus Color 740).....	41

## ***Operating Principles***

---

Overview.....	43
Printer Mechanism.....	44
Electrical Circuit Operating Principles.....	56
C206 PSB/PSE and C257 PSB/PSE Power Supply Board (for Stylus Color 440, 640, 740) .....	57
C206 Main-B, C255 Main (for Stylus Color 440) .....	60
C256 Main (for Stylus Color 640) .....	62
C257 Main, (for Stylus Color 740) .....	64

## ***Troubleshooting***

---

Troubleshooting.....	82
Unit Level Troubleshooting .....	85
Printer does not operate at power on. ....	85
Error is detected .....	86
Failure occurs during printing .....	86
Printer does not feed paper correctly. ....	87
Control panel operation is abnormal.....	87
Unit Repair of Power Supply Board .....	88
Unit Repair of the Main Board .....	91
Repair of the Printer Mechanism .....	96

## ***Disassembly and Assembly***

---

Overview.....	100
Precautions for Disassembling the Printer .....	100
Tools.....	101
Specification for Screws .....	102
Service Checks After Repair .....	103

Disassembly Procedures.....	104
Removing the Housing.....	105
Removing the Board Assembly.....	106
Removing the Operation Panel.....	108
Disassembling the Printer Mechanism.....	109

## ***Adjustment***

---

Overview.....	130
Required Adjustments.....	130
Adjustment Tools Required.....	131
Adjustment.....	132
Parallelism Adjustment.....	132
Adjustment by Adjustment Program.....	134

## ***Maintenance***

---

Overview.....	154
Cleaning.....	154
Service Maintenance.....	154
Lubrication.....	155

## ***Appendix***

---

Connector Summary.....	161
Connector Summary (Stylus Color 440/640).....	162
Connector Summary for Stylus Color 740.....	166
EEPROM Address Map.....	169
EEPROM ADDRESS Map (Stylus Color 440/640).....	169
EEPROM Address Map (Stylus Color 740).....	174
Circuit Board Component Layouts.....	178
Exploded Diagrams.....	188
Part List.....	198
Part List for Stylus Color 440/640.....	198
Part List for Stylus Color 740.....	200
Circuit Diagrams.....	202

**CHAPTER**

**1**

**PRODUCT DESCRIPTION**



## 1.1 FEATURES

---

EPSON Stylus Color 440/640/740 are designed for PC users at home and low price for hat high performance. Also, Stylus Color 440 printer has the same high color print quality (720 X 720dpi) as Stylus ProXL, and Stylus Color 640,740 have the same high color print quality (1440 X 720) as Stylus Color 600 and Stylus Pro 5000. The major printer features are;

- High color print quality
  - 720 (H) x 720 (V) dpi printing (for Stylus Color 440)
  - 1440 (H) X 720 (V) dpi printing (for Stylus Color 640,740)
  - 4 color printing (YMCBk)
  - Traditional and New Microwave
  - Black 64 nozzles, CMY 21 nozzles (for Stylus Color 440)
  - Black 64 nozzles, CMY 32/color nozzles (for Stylus Color 640)
  - Black 144 nozzles, CMY 48/color nozzles (for Stylus Color 740)
- Built-in auto sheet feeder
  - Holds 100 cut-sheets (55g/m<sup>2</sup>)
  - Holds 10 envelopes
  - Holds 10 transparency films
  - Holds 65 special papers
- High-speed print
  - 200 cps (for Stylus Color 440, 740)
  - Normal 200 cps, Draft 400 cps (only for Stylus Color 640)
  - By using head drive frequency 14.4KHz, printing speed is twice faster than Stylus Color.
- Compact size
  - 429mm (W) x 231mm (D) x 155mm (H) (for Stylus Color 440)
  - 429mm (W) x 231mm (D) x 157mm (H) (for Stylus Color 640)
  - 429mm (W) x 261mm (D) x 157mm (H) (for Stylus Color 740)
  - Weight: 5.2Kg (for 3 models)
- Acoustic noise
  - Approximately 45 dB (for Stylus Color 440)
  - Approximately 47 dB (for Stylus Color 640, 740)
- Interface
  - Bi-directional parallel I/F IEEE-1284 level 1 device (for 3 models)
  - Serial I/F up to 1800 bps (only for Stylus Color 640)
  - USB
- One unit combined black and CMY head
- Windows exclusive (for Stylus Color 440, 640)
- Standard, NLSP, 5 Scaleable fonts (only for Stylus Color 740)

See Table 1-1 in the following page for the consumable list.

Table 1-1. Consumables Available for Stylus Color 440/640/740

Items	Codes	Remarks
Black Ink Cartridge	S020189	Stylus Color 740
Black Ink Cartridge	S020187	Stylus Color 440,640
CMY Ink Cartridge	S020191	Stylus Color 440,640,740
CMY Ink Cartridge		
EPSON 360 dpi Ink Jet Paper	S041025	Size: A4 (200 sheets)
EPSON 360 dpi Ink Jet Paper	S041059	Size: A4 (100 sheets)
EPSON 360 dpi Ink Jet Paper	S041060	Size: Letter (100 sheets)
Photo Quality Ink Jet Paper	S041026	Size: A4 (200 sheets)
Photo Quality Ink Jet Paper	S041061	Size: A4 (100 sheets)
Photo Quality Ink Jet Paper	S041062	Size: Letter
Photo Quality Ink Jet Paper	S041067	Size: Legal
Photo Quality Glossy Paper (New Release)	S041126	Size: A4
Photo Quality Glossy Paper (New Release)	S041124	Size: Letter
Photo Quality Glossy Film	S041071	Size: A4
Photo Quality Glossy Film	S041124	Size: Letter
Photo Quality Glossy Film	S041107	Size: A6
Ink Jet Transparencies	S041063	Size: A4
Ink Jet Transparencies	S041064	Size: Letter
Photo Quality Ink Jet Card	S041054	Size: A6
Photo Quality Ink Jet Card	S041121	Size: 5 x 8 inches
Photo Quality Ink Jet Card	S041122	Size: 10 x 8 inches
Photo Quality Self Adhesive Sheet	S041106	Size: A4

## 1.2 Specifications

This section describes each specification for Stylus Color 440, 640, and 740.

### 1.2.1 Printing Specification

- Print method
  - On demand ink jet (MACH type. One unit combined with black and CMY head)
- Nozzle configuration
  - Black 64 nozzles, CMY 21 nozzles (for Stylus Color 440)
  - Black 64 nozzles, CMY 32/color nozzles (for Stylus Color 640)
  - Black 144 nozzles, CMY 48/color nozzles (for Stylus Color 740)
- Print direction
  - Bi-direction with logic seeking
- Print speed and Printable columns, character pitch and print quality  
Refer to Table 1-2 and Table 1-3.

**Table 1-2. Character Mode Speed**

Model Name	Character Pitch	Printable Column	LQ Speed	Draft Speed
Stylus Color 440	10	80	200 CPS	---
Stylus Color 640	10	80	200 CPS	400 CPS
Stylus Color 740	10	80	200 CPS	---

**Table 1-3. Graphic Mode Speed**

Horizontal Resolution	Printable Area	Available dot	CR Speed
180 dpi	8.26	1488	20 IPS
360 dpi	8.26	2976	20 IPS
720 dpi	8.26	5952	20 IPS

- Nozzle Configuration:
  - Refer to Figure 1-1 for Stylus Color 440.
  - Refer to Figure 1-2 for Stylus Color 640.
  - Refer to Figure 1-3 for Stylus Color 740.

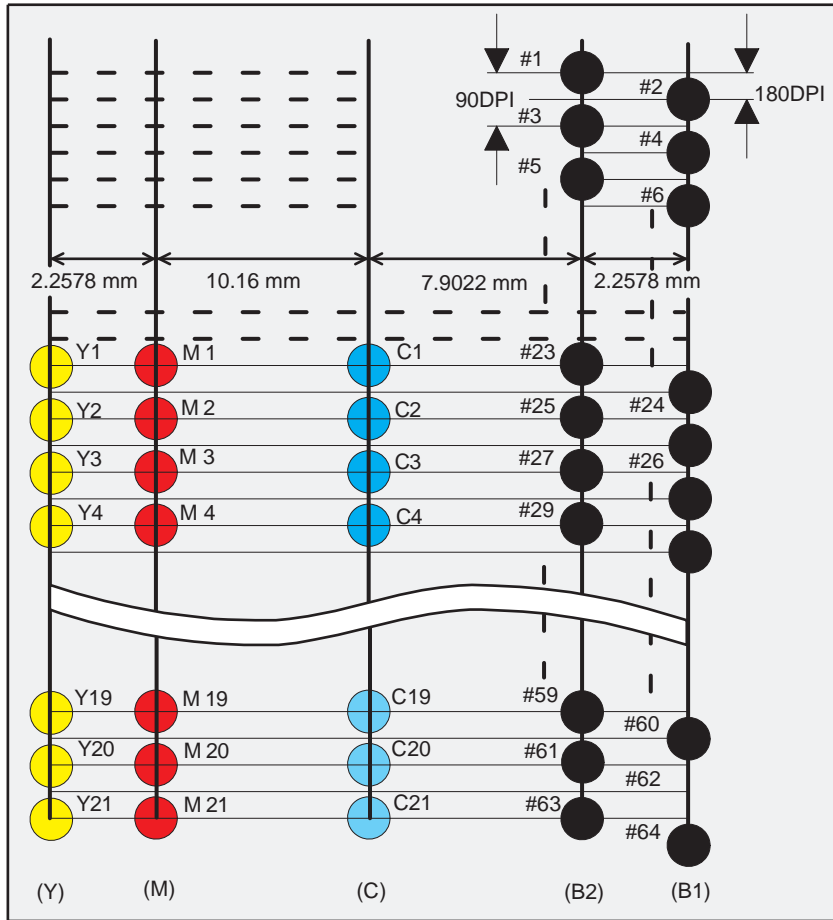

Figure 1-1. Nozzle Configuration for Stylus Color 440

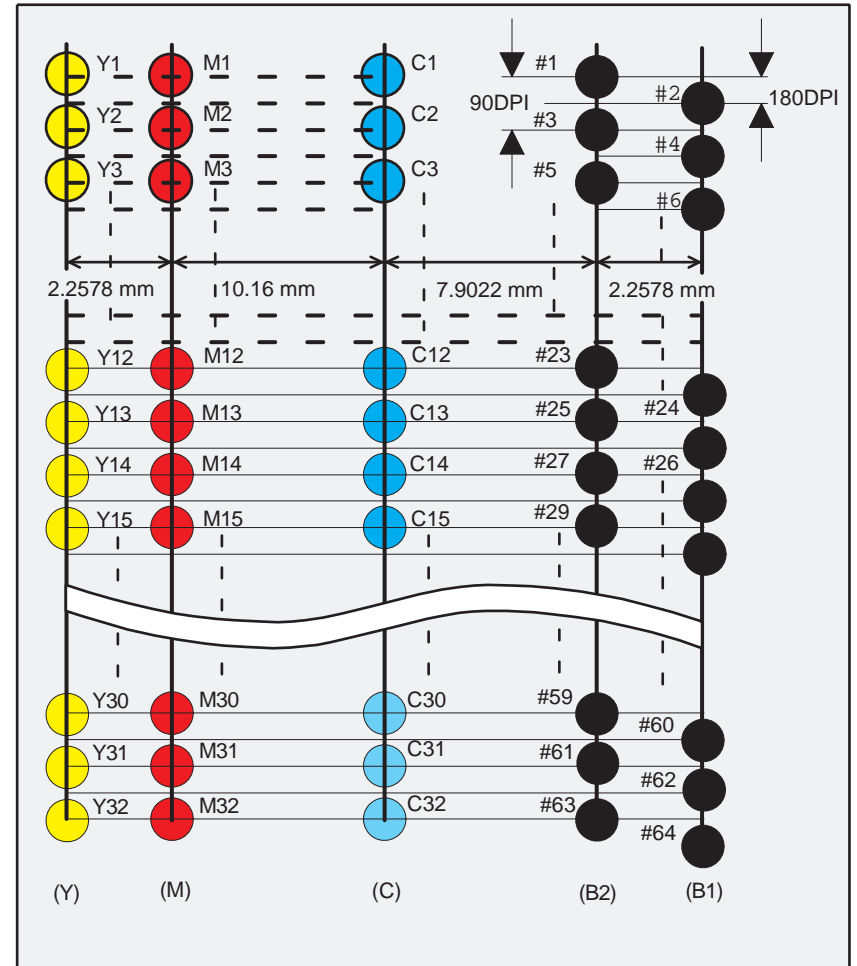

Figure 1-2. Nozzle Configuration for Stylus Color 640

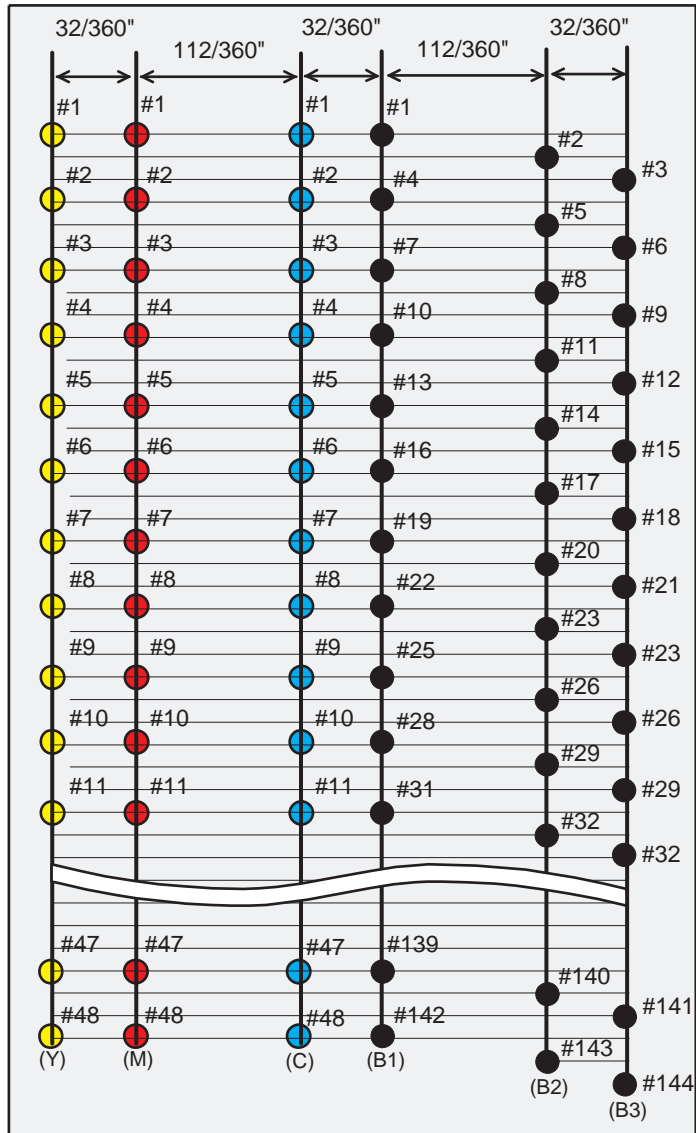

Figure 1-3. Nozzle Configuration for Stylus Color 740

- Feeding method
  - Friction feed with ASF
- Line spacing
  - 1/6 inches or programmable at 1/360 inches (only for Stylus Color 440)
  - 1/6, 1/8 inches or programmable at 1/360 inches (for Stylus Color 640,740)
- Paper path
  - Cut-sheet ASF (Top entry)
- Feeding speed
  - <Stylus Color 440, 640>
    - 190 ms (1/3 inch)
    - 2.0 inches/seconds (continuous)
  - <Stylus Color 740>
    - 110 ms (10.16 mm)
    - 114.3 mm/second (Continuous)
- Ink supply
  - Exclusive ink cartridge (Black and CMY)

- Paper holding capacity of Hopper
  - Size: Index card ~Legal
  - Thickness: Less than 8mm
  - Paper capacity: 100 Cut sheets  
10 Envelopes  
65 Coated papers (360 dpi)  
65 Coated papers (720 dpi)  
20 Glossy papers, Photo Paper  
10 Transparent sheets  
30 Index cards  
1 Panoramic Photo Paper, Iron-On Cool Peel Transfer Paper, and Photo Sticks, Glossy Film, Self Adhesive
- Character tables: 2 international character sets (Not Opened)
  - <Stylus Color 440, 640>
    - PC437 (US, Standard Europe)
    - PC850 (Multilingual)
- Typeface
  - Bit map LQ font: EPSON Courier 10CPI
    - <Stylus Color 740>
    - Standard version: 11 character tables  
Italic table, PC437 (US Standard, Europe), PC 850 (Multilingual), PC860 (Portuguese), PC861 (Icelandic), PC863 (Canadian-French), PC865 (Nordic), Abicomp, BRASCII, Roman 8, ISO Latin 1
    - NLSP Version: 30 character tables  
Italictable, PC437, PC437 Greek, PC 850, PC852, PC853, PC855, PC857, PC860, PC861, PC865, PC866, ISO8859-7, ISO Latin 1T,

Bulgaria,ic),PC774,Estonia,ISO8859-2,PC866-LAT,PC866UKR, PC AR864, PC APTEC, PC708, PC720, Hebrew7\*1 Hebrew8\*1, PC862\*1

**NOTE:** \*1 is not opened. These character tables can not be selected in the default setting mode.

- Typeface
  - Bit map LQ font:
 

EPSON Roman	10 CPI, 12 CPI, 15 CPI, Proportional
EPSON Sans Serif	10 CPI, 12 CPI, 15 CPI, Proportional
EPSON Courier	10 CPI, 12 CPI, 15 CPI
EPSON Prestige	10 CPI, 12 CPI, 15 CPI
EPSON Script	10 CPI, 12 CPI, 15 CPI
  - Scaleable font:
 

EPSON Roman	10.5pt., 8pt. to 32 pt. (every 2 pt. unit)
EPSON Sans Serif	10.5pt., 8pt. to 32 pt. (every 2 pt. unit)
EPSON Roman T	10.5pt., 8pt. to 32 pt. (every 2 pt. unit)
EPSON Sans Serif H	10.5pt., 8pt. to 32 pt. (every 2 pt. unit)

**NOTE:** The above typeface has 4 variations individually as follows;  
EPSON Roman, EASON Roman bold  
EPSON Roman Italic, EPSON Roman bold Italic

- Control code
  - <Stylus Color 440, 640>
    - ESC/P Raster
    - EPSON Remote command
  - <Stylus Color 740>
    - ESC/P2 and ESC/P Raster
    - EPSON Remote command

## 1.2.2 Paper Specification

This section describes the printable area and types of paper that can be used in this printer.

### 1.2.2.1 Cut Sheet

#### [Size]

A4: [Width 210mm (8.3") x Length 297mm (11.7")]  
 Letter: [Width 216mm (8.5") x Length 279mm (11.0")]  
 B5: [Width 182mm (7.2") x Length 257mm (10.1")]  
 Legal: [Width 216mm (8.5") x Length 356mm (14.0")]  
 Statement: [Width]139.7mm (5.5") x Length 215.9mm (8.5")]  
 Exclusive: [Width 190.5mm (7.5") x Length 254mm (10")]

#### [Thickness]

0.08mm (0.003") - 0.11mm (0.004")

#### [Weight]

64g/m<sup>2</sup> (17lb.) - 90g/m<sup>2</sup> (24lb.)

#### [Quality]

Exclusive paper, Bond paper, PPC

### 1.2.2.2 Transparency, Glossy Paper

#### [Size]

A4: [Width 210mm (8.3") x Length 297mm (11.7")]  
 Letter: [Width 216mm (8.5") x Length 279mm (11.0")]

#### [Thickness]

0.075mm(0.003") - 0.085mm(0.0033")

**NOTE:** Transparency printing is only available at normal temperature.

### 1.2.2.3 Envelope

#### [Size]

No.10 Width 241mm (9 1/2") x Length 104.8mm (4 1/8")  
 DL Width 220mm (8.7") x Length 110mm (4.3")  
 C6 Width 162mm (6.4") x Length 114mm (4.5")

#### [Thickness]

0.16mm (0.006") - 0.52mm (0.02")

#### [Weight]

45g/m<sup>2</sup> (12lb.) - 75g/m<sup>2</sup> (20lb.)

#### [Quality]

Bond paper, Plain paper, Air mail

**NOTE 1** Envelope printing is only available at normal temperature.

**NOTE 2** Keep the longer side of the envelope horizontally at setting.

#### 1.2.2.4 Index Card

**[Size]**

A6 Index card:       Width 105mm (4.1") x Length 148mm (5.8")

A5 Index card:       Width 148mm (5.8") x Length 210mm (8.3")

5x8" Index card:     Width 127mm (5.0") x Length 203mm (8.0")

10x8" Index card:    Width 127mm (5.0") x Length 203mm (8.0")

**[Thickness]** : Less than 0.23mm (0.0091")



### 1.2.3 Printing Area

**[Cut Sheet]**

See Figure 1-4 in the right column and the tables in the following page for the printable areas for Raster Graphics mode and Character mode.

**NOTE:** Character mode is only suitable for Stylus Color 740.

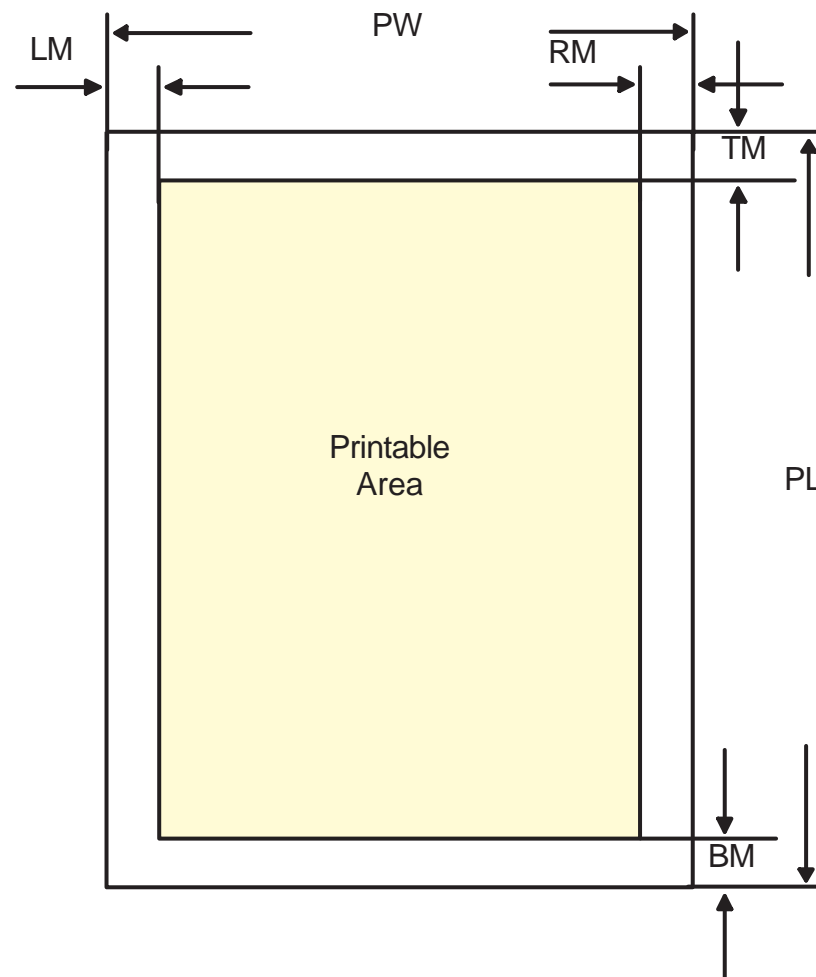

Figure 1-4. Printable Area for Cut sheet

Table 1-4. Raster Graphics Mode (for 3 models)

Paper Size	PW	PL	LM	RM	TM	BM/min.
A4	210 mm (8.3")	297 mm (11.7")	3 mm (0.12")	3 mm (0.12")	3 mm (0.12")	14 mm(0.54") 3 mm (0.12")
Letter	216 mm (8.5")	279 mm (11.0")	3 mm (0.12")	9 mm (0.35")	3 mm (0.12")	14 mm (0.54") 3 mm (0.12")
B5	182 mm (7.2")	257 mm (10.1")	3 mm (0.12")	3 mm (0.12")	3 mm (0.12")	14 mm (0.54") 3 mm (0.12")
Legal	216 mm (8.5")	356 mm (14.0")	3 mm (0.12")	9 mm (0.35")	3 mm (0.12")	14 mm (0.54") 3 mm (0.12")
Statement	139.7 mm (5.5")	215.9 mm (8.5")	3 mm (0.12")	3 mm (0.12")	3 mm (0.12")	14 mm (0.54") 3 mm (0.12")
Exclusive	190.5 mm (7.5")	254 mm (10")	3 mm (0.12")	3 mm (0.12")	3 mm (0.12")	14 mm (0.54") 3 mm (0.12")

Table 1-5. Character Mode (only for Stylus Color 740)

Paper Size	PW	PL	LM	RM	TM	BM/min.
A4	210mm (8.3")	297mm (11.7")	3mm (0.12")	3mm (0.12")	3mm (0.12")	14mm (0.54") 3 mm (0.12")
Letter	216mm (8.5")	279mm (11.0")	3mm (0.12")	9mm (0.35")	3mm (0.12")	14mm (0.54") 3 mm (0.12")
B5	182mm (7.2")	257mm (10.1")	3mm (0.12")	3mm (0.12")	3mm (0.12")	14mm (0.54") 3 mm (0.12")
Legal	216mm (8.5")	356mm (14.0")	3mm (0.12")	9mm (0.35")	3mm (0.12")	14mm (0.54") 3 mm (0.12")
Statement	139.7mm (5.5")	215.9mm (8.5")	3mm (0.12")	3mm (0.12")	3mm (0.12")	14mm (0.54") 3 mm (0.12")
Exclusive	190.5mm (7.5")	254mm (10")	3mm (0.12")	3mm (0.12")	3mm (0.12")	14mm (0.54") 3 mm (0.12")

[Envelope]

Table 1-6 and Figure 1-5 show the printable area for envelopes.

**Table 1-6. Envelopes Margin**

Paper Size	LM	RM	TM	BM/min.
#10	28 mm (1.10")	3 mm (0.12")	3 mm (0.12")	14 mm (0.54") 3 mm (0.12")
DL	7 mm (0.28")	3 mm (0.12")	3 mm (0.12")	14 mm (0.54") 3 mm (0.12")
C6	3 mm (0.12")	3 mm (0.12")	3 mm (0.12")	14 mm (0.54") 3 mm (0.12")

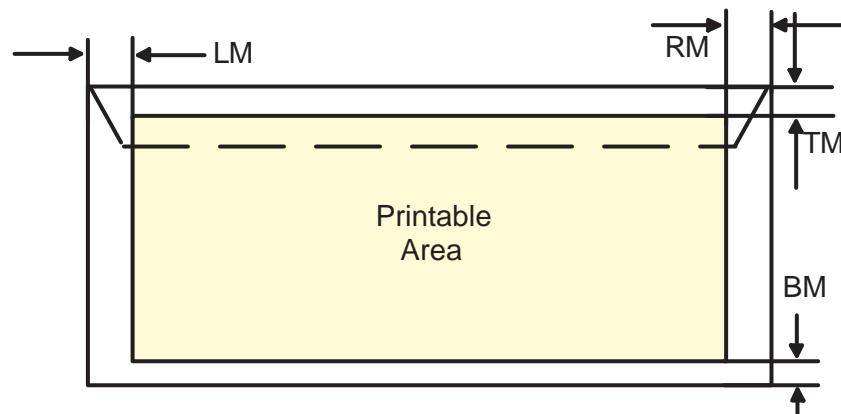

**Figure 1-5. Printable Area for Envelopes**

**1.2.3.1 Adjust Lever Setting**

The adjustment lever located on the right side (dark blue) under the printer cover needs to be set to the proper position according to the paper you print. (Refer to the Table 1-7.) Also, if there is any dirt caused by friction on the way or wrinkled paper, this can be prevented by changing the lever position to rear position (marked with “+”) in spite of paper types.

**Table 1-7. Adjust Lever Setting**

Lever Position	Clearance between head and platen
Plus Position	1.04 mm
Zero Position	1.74 mm (+0.7 mm)

**NOTE:** Return the adjust lever to the zero position, which is normal position, after you finish printing on all media. Leaving the lever in the plus position may cause the printed image to have gaps on other media.

## 1.2.4 Ink Cartridge Specifications

### [Black Ink Cartridge]

**Table 1-8. Black Cartridge Specifications**

Items	Specifications
Type	Exclusive Cartridge for Stylus Color 440, 640 Exclusive Cartridge only for Stylus Color 740
Color	Black
Print Capacity	<Stylus Color 440,640> 540 pages / A4 (ISO/IEC 10561 Letter Pattern at 360 dpi) <Stylus Color 740> 900 pages / A4 (ISO/IEC 10561 Letter Pattern at 360 dpi)
Validity	2 years (sealed in package) / 6 months (out of package)
Environmental conditions	<ul style="list-style-type: none"> <li>Temperature                             <ul style="list-style-type: none"> <li>- Storage: -20°C~40°C (within a month at 40 °C)</li> <li>- Packing storage: -30°C~40°C (within a month at 40 °C)</li> <li>- Transit: -30°C~60°C (within 120 hours at 60°C and within a month at 40°C)</li> </ul> </li> <li>Humidity                             <ul style="list-style-type: none"> <li>5% to 85% (without condensation)</li> </ul> </li> </ul> <p><b>Note:</b> Ink freezes below -3°C, but it returns to normal after 3 hours at room temperature. (25 °C)</p> <ul style="list-style-type: none"> <li>Dimension                             <ul style="list-style-type: none"> <li>&lt;Stylus Color 440,640&gt; 19.8 mm (W) X 52.7 mm (D) X 38.5 mm (H)</li> <li>&lt;Stylus Color 740&gt; 27.8 mm (W) X 52.7 mm (D) X 38.5 mm (H)</li> </ul> </li> </ul>
Weight	Total Ink Cartridge: 30 g Total Ink: 16.4 +/-0.5 g Consumable Ink weight: more than 12.1 g

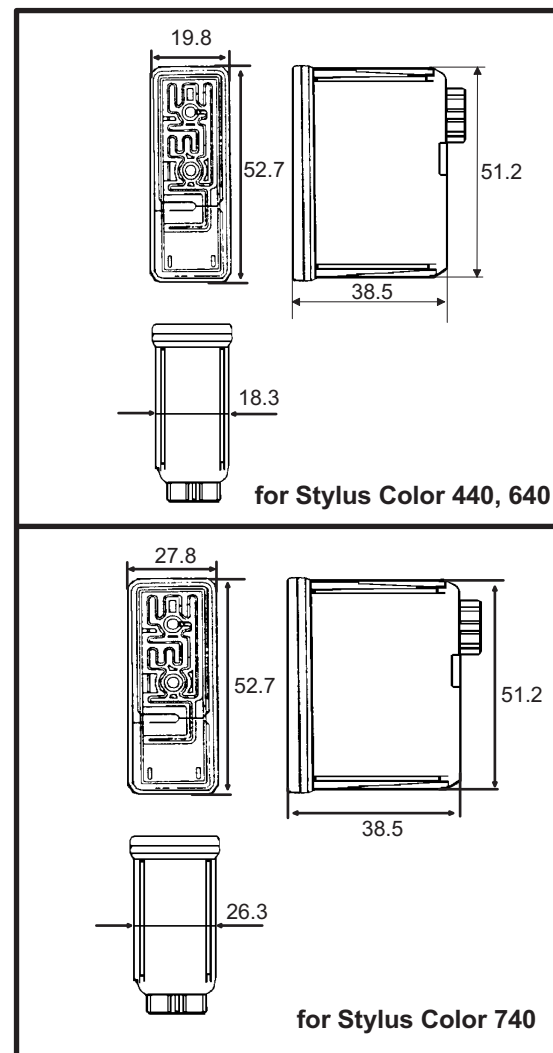

**Figure 1-6. Black Ink Cartridge Appearance**

[Color Ink Cartridge]

Table 1-9. Color I/C Specifications

Items	Specifications
Type	Exclusive Cartridge for Stylus Color 440, 640, 740
Color	CMY
Print Capacity	300 pages / A4 (360 dpi, 5% duty each colors)
Validity	2 years (sealed in package) / 6 months (out of package)
Environmental conditions	<ul style="list-style-type: none"> <li>Temperature                             <ul style="list-style-type: none"> <li>- Storage: -20°C~40°C (within a month at 40 °C)</li> <li>- Packing storage: -30°C~40°C (within a month at 40 °C)</li> <li>- Transit: -30°C~60°C (within 120 hours at 60°C and within a month at 40°C)</li> </ul> </li> <li>Humidity                             <ul style="list-style-type: none"> <li>5% to 85% (without condensation)</li> </ul> </li> </ul> <p><b>Note:</b> Ink freezes below -3°C, but it returns to normal after 3 hours at room temperature. (25 °C)</p> <ul style="list-style-type: none"> <li>Dimension                             <ul style="list-style-type: none"> <li>42.9 mm (W) X 52.7 mm (D) X 38.5 mm (H)</li> </ul> </li> </ul>
Weight	Total Ink Cartridge: 67 g Total Ink: 12.8 +/-0.5 g/colors Consumable Ink weight: more than 9.6 g/colors

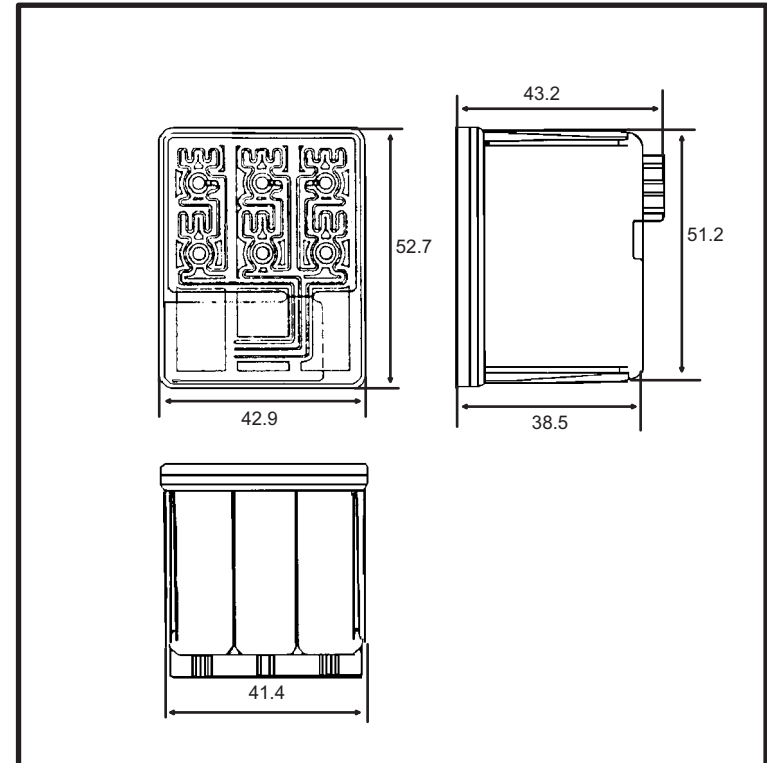

Figure 1-7. Color Ink Cartridge

## 1.2.5 Environmental Condition

### □ Temperature

- Operating :10 to 35 °C (Refer to Figure 1-8 for condition)
- Non-operating:-20 to 60 °C (with shipment container)

**NOTE:** 1 month at 40 °C and 120 hours at 60 °C

### □ Humidity

- Operating: 20% ~ 80% RH  
(without condensation Refer to Figure 1-8 for condition)
- Non-operating: 5% ~ 85% RH  
(without condensation and with shipment container)

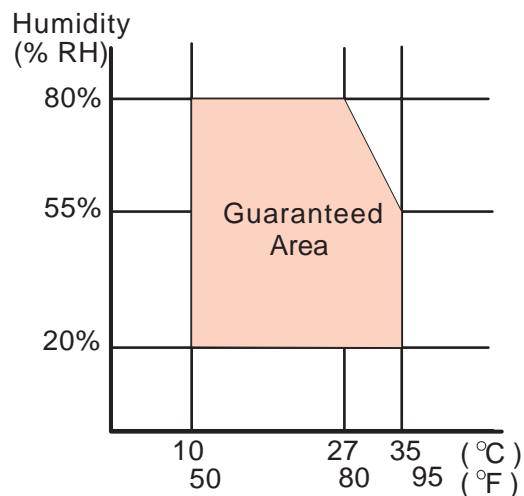

Figure 1-8. Temperature / Humidity of Range

### □ Resistance to shock

- Operating: 1G, within 1 ms  
X,Y,Z directions
- Non-operating:2G, within 2 ms  
X,Y,Z directions (with shipment container)

### □ Resistance to vibration

- Operating: 0.15G (Operating)
- Non-operating:0.50G (Non-Operating)

**NOTE 1:**During non-operating, make sure that the head is capped.

**NOTE 2:**During the transport, make sure that the head is capped and ink cartridge is installed to the printer.

**NOTE 3:** If the head is not capped at the power-off state, turn the power on with installed ink cartridge and turn off the power after confirming that Power on operation is completed and the head is capped.

**NOTE 4:** Ink will be frozen less than -3°C environment, however it will be usable after placing it more than 3 hours at 25°C.

## 1.2.6 Electric Specification

### [120V version]

[Rated voltage]	AC120V
[Input voltage range]	AC99~132V
[Rated frequency range]	50~60Hz
[Input frequency range]	49.5~60.5Hz
[Rated current]	0.4A (Max. 0.5A)
[Power consumption]	Approx.15W (ISO/IEC 10561 Letter pattern) Energy Star compliant
[Insulation Resistance]	10M ohms min. (between AC line and chassis, DC 500 V)
[Dielectric strength]	AC1000 V rms. 1 minute or AC1200 Vrms. 1 second (between AC line and chassis)

### [220~240V version]

[Rated voltage]	AC220V~240V
[Input voltage range]	AC198~264V
[Rated frequency range]	50~60Hz
[Input frequency range]	49.5~60.5Hz
[Rated current]	0.2 A (Max. 0.3A)
[Power consumption]	Approx.15W (ISO/IEC 10561 Letter pattern) Energy Star compliant
[Insulation Resistance]	10M ohms min. (between AC line and chassis, DC500V)
[Dielectric strength]	AC1500 V rms. 1 minute (between AC line and chassis)

## 1.2.7 Reliability

### [Total print volume]

Stylus Color 440:	10,000 pages (A4, Letter)
Stylus Color 640:	25,000 pages (A4, Letter)
Stylus Color 740:	75,000 pages (A4, Letter)

### [Print head life]

Stylus Color 440:	2000 million dots/nozzle
Stylus Color 640:	2000 million dots/nozzle
Stylus Color 740:	4000 million dots/nozzle

## 1.2.8 Safety Approvals

### [120V version]

Safety standard	UL1950 with D3 CSA22.2 No.950 with D3
EMI	FCC part 15 subpart B class B CSA C108.8 class B

### [220~240V]

Safety standard	EN 60950 (VDE,NEMKO)
EMI	EN55022 (CISPR Pub.22) class B AS/NZS 3548 class B

## 1.2.9 Acoustic Noise

Stylus Color 440: Approximately 45 dB

Stylus Color 640,740: Approximately 47 dB

## 1.2.10 CE Marking

[220~240 V version]

Low Voltage Directive 73/23/EEC:EN60950

EMC Directive 89/336/EEC :EN55022 Class B  
:EN61000-3-2  
:EN61000-3-3  
:EN50082-1  
:IEC801-2  
:IEC801-3  
:IEC801-4

## 1.2.11 Input Data Buffer

10 K byte (for Stylus Color 440)

32 K byte (for Stylus Color 640)

64 K byte (for Stylus Color 740)



## 1.3 Interface

---

This printer provides parallel interface as standard.

### 1.3.1 Parallel Interface (Forward Channel)

**[Transmission mode]** 8 bit parallel, IEEE-1284 compatibility mode

**[Synchronization]** By /STOPBE pulse

**[Handshaking]** BY BUSY and /ACKLG signal

**[Signal level]** TTL compatible level

**[Adaptable connector]** 57-30360 (amphenol) or equivalent

BUSY signal is set high before setting either/ERROR low or PE high and held high until all these signals return to their inactive state.

BUSY signal is at high level in the following cases.

- During data entry (see Data transmission timing)
- When input data buffer is full
- During -INIT signal is at low level or during hardware initialization
- During printer error (See /ERROR signal)

/ERROR signal is at low level when the printer is in one of the following states.

- Printer hardware error (fatal error)
- Paper-out error
- Paper-jam error
- Ink-out error

PE signal is at high level during paper-out error.

See Table 1-10 in the following page which shows the signal and connector pin assignments for parallel interface (forward channel \*1). In case of these signals, twist pair line is used and returning side is connected to signal GND.

*\*1: Forward channel is the mode when the ordinary data such as an order to print is sent from the PC to the printer.*

Table 1-10. Parallel I/F Forward Channel

Pin No.	Signal Name	Return GND Pin	In/Out	Functional Description
1	/STROBE	19	I	The strobe pulse. Read-in of data is performed at the falling edge of this pulse.
2-9	DATA0-7	20-27	I	The DATA0 through DATA7 signals represent data bits 0 to 7, respectively. Each signal is at high level when data is logical 1 and low level when data is logical 0.
10	/ACKNLG	28	O	This signal is a negative pulse indicating that the printer can again accept data.
11	BUSY	29	O	A high signal indicates that the printer cannot receive data.
12	PE	28	O	A high signal indicates paper-out error.
13	SLCT	28	O	Always at high level when the printer is powered on.
14	/AFXT	30	I	Not used.
31	/INIT	30	I	The falling edge of a negative pulse or a low signal on this line causes the printer to initialize. Minimum 50 us pulse is necessary.
32	/ERROR	29	O	A low signal indicates printer error condition.
36	/SLIN	30	I	Not used.
18	Logic H	----	O	Pulled up to +5V via 3.9K ohm resistor.
35	+5V	----	O	Pulled up to +5V via 3.9K ohm resistor.
17	Chassis GND	----	---	Chassis GND.
16,33, 19-30	GND	----	---	Signal GND.
15,34	NC	----	---	Not connected.

Note) In and Out refer to the direction of signal flow from the printer's point of view.

### 1.3.2 Parallel Interface (Reverse Channel)

[Transmission mode]	IEEE-1284 nibble mode
[Synchronization]	Refer to the IEEE-1284 specification
[Handshaking]	Refer to the IEEE-1284 specification
[Data trans. timing]	Refer to the IEEE-1284 specification
[Signal level]	IEEE-1284 level 1 device TTL compatible level
[Adaptable connector]	57-30360 (amphenol) or equivalent
[Extensibility request]	The printer responds affirmatively when the extensibility request values are 00H or 04H, that mean; 00H: Request Nibble Mode Reverse Channel Transfer. 04H: Request device ID; Return Data using Nibble Mode Rev Channel Transfer.

**NOTE:** The printer sends following device ID string when it is requested.

**Table 1-11. Details of Device ID**

00H	3CH	Contents
MGF	EPSON;	Production Maker
CMD	ESCPL2,BDC;	Command system
MDL	Stylus[SP]Color[SP] 440; Stylus[SP]Color[SP] 640; Stylus[SP]Color[SP] 740;	Model name
CLS	PRINTER;	Class

**NOTE:** [00H] denotes a hexadecimal value of zero. MDL value depends on the EEPROM setting.

**NOTE:** MDL value depends on the EEPROM setting. Model name can be changed by changing a certain address in the EEPROM.

Table 1-12 shows pin assignment for reverse channel (\*3). In these case of signals, twist pair line is used and returning side is connected to Signal GND.

\*3: Reverse channel is the mode that any data is transferred from the printer to the PC.

Table 1-12. Parallel I/F Reverse Channel

Pin No.	Signal Name	Return GND Pin	In/Out	Functional Description
1	HostClk	19	I	Host clock signal.
2-9	Data0-7	20-27	I	The DATA0 through DATA7 signals represent data bits 0 to 7, respectively. Each signal is at high level when data is logical 1 and low level when data is logical 0. These signals are used to transfer the 1284 extensibility request values to the printer.
10	PrtClk	28	O	Printer clock signal.
11	PtrBusy, Data Bit-3,7	29	O	Printer busy signal and reverse channel transfer data bit 3 or 7.
12	AckData Req, DataBit-2,6	28	O	Acknowledge data request signal and reverse channel transfer data bit 2 or 6.
13	Xflag, DataBit-1,5	28	O	X-flag signal and reverse channel transfer data bit 1 or 5.
14	HostBusy	30	I	Host busy signal.
31	/INIT	30	I	Not used.
32	/DataAvail, DataBit-0,4	29	O	Data available signal and reverse channel transfer data bit 0 or 4.
36	1284-Active	30	I	1284 Active Signal
18	Logic-H	----	O	Pulled up to +5V via 3.9K ohm resistor.
35	+5V	----	O	Pulled up to +5V via 3.3K ohm resistor.
17	Chassis GND	----	---	Chassis GND.
16,33, 9-30	GND	----	---	Signal GND.
15,34	NC	----	---	Not connected.

Note) In/Out refers to the direction of signal flow from the printer's point of view.

The following are the points to note when using the parallel Interface.

**NOTE 1:**“Return GND pin” in the table means twist pair return and is used for all control signals except for Logic H,+5V, Chassis, GND and NC. In this twist pair return, returning side is connected to GND (16,33, 19-30 pin) for twist pair return. Also, these cables are shielded wires and it is effective to connect to each chassis GND in the PC and printer for electrostatic noise.

**NOTE 2:**Conditions for Interface are based on TTL level. Rise and fall time should be within 0.2μs.

**NOTE 3:**Refer to Figure 1-9 for transmission timing of each signals.

**NOTE 4:**Do not perform data transmission ignoring /ACK or BUSY signal. (Perform the data transmission after confirming that /ACK and BUSY signals are Low.)

**NOTE 5:**It is possible to perform the printing test including interface circuit without using equipment from outside when 8-bit data signal (20-27 pin) is set to appropriate word code and connect them forcefully to /ACK and /STRB.

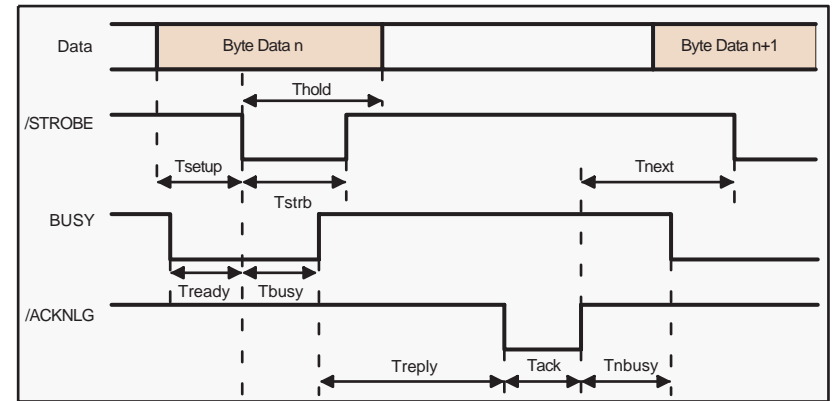

Figure 1-9. Data Transmission Timing for Forward Channel

Table 1-13. Maximum and Minimum Timing for Data Transmission

Parameter	Minimum	Maximum
tsetup	500ns	---
thold	500ns	---
tstb	500ns	---
tready	0	---
tbusy	---	500ns
tt-out*	---	120ns
tt-in**	---	200ns
treply	0	---
tack	500ns	10us
tnbusy	0	---
tnext	0	---

\* Rise and fall time of every output signal.

\*\* Rise and fall time of every input signal. Typical timing for the tack parameter is shown below.

Table 1-14. Typical Tack Timing

Parallel I/F Mode	Typical Tack Timing
High speed	2us (for Stylus Color 440,640) 1us (only for Stylus Color 740)
Normal speed	4us (for Stylus Color 440,640) 3us (only for Stylus Color 740)

Table 1-15. Signal level for TTL (IEEE-1284 level 1 device)

Parameters	Minimum	Maximum	COndition
VOH*	---	5.5V	
VOL*	-0.5V	---	
IOH*	---	0.32mA	VOH = 2.4V
IOL	---	12mA	VOL = 0.4V
CO	---	50pF	
VIH	---	2.0V	
VIL	0.8V	---	
IIH	---	0.32mA	VIH = 2.0V
IIL	---	12mA	VIL = 0.8V
CI	---	50pF	

**NOTE:** A low logic level on the Logic H signal is 2.0V or less when the printer is powered off and this signal is equal or exceeding 3.0V when the printer is powered on. The receiver shall provide an impedance equivalent to 7.5K ohm to ground.

### 1.3.2.1 Prevention Hosts from Data Transfer time-out

Generally, hosts abandon data transfer to peripherals when a peripheral is in the busy state for dozens of seconds continuously. To prevent hosts this kind of time-out, the printer receives data very slowly, several bytes per minute, even if the printer is in busy state. This showdown is started when the rest of the input buffer becomes several hundreds of bytes. Finally, the printer is in the busy state continuously when the input buffer is full.

### 1.3.2.2 Auto Interface Selection (for Stylus Color 640, 740)

- Manual Selection:  
One of two interfaces can be selected by the default setting mode.
- Automatic Selection:  
The automatic interface selection is enabled by the default setting mode. In this automatic interface selection mode, the printer is initialized to the idle state scanning which interface receives data when it is powered on. Then the interface that receives data first is selected. When the host stops data transfer and the printer is in the stand-by state for the seconds, the printer is returned to the idle state. As long as the host sends data or the printer interface is busy state, the selected interface is let as it is.

Following explains conditions of other interfaces when a particular interface is selected.

- When the parallel interface is not selected, the interface gets into BUSY state. At this time, LH signal is set to "L". That means blocking power supply and no responds from 1284. Therefore, it is necessary for the host, which requires Reverse transfer, to check LH state.
- When the serial interface is not selected, the interface sets the DTR signal MARK.
- When the printer is initialized or returned to the idle state, Parallel interface becomes the ready condition and DTR of serial interface becomes SPACE (Low) condition and reset off-line bit of Main Status Register (MNSTS)to, option interface.

### 1.3.3 Serial Interface (for Stylus Color 640, 740)

[Standard] Based on RS-423  
 [Synchronization] Synchronous  
 [Bit Rate] Approx.1800Kbps  
 [Handshaking] X-ON/X-OFF, DTR Protocol  
 [Word Format] Data Bit= 8 bits  
 Parity Bit= None  
 Start Bit= 1 bit  
 Stop Bit= 1 bit  
 [Connector] 8-pin mini-circular connector  
 [Recommended Cable] Apple System Peripheral-8 Cable

**Table 1-16. Pin Assignment**

Pin No.	Signal Name	I/O	Description
1	SCLK	O	Synchronous clock signal
2	CTS	I	Clear To Send
3	TXD-	O	Transmit Data (-)
4	SG	I	(Signal Ground)
5	RXD-	I	Receive Data (-)
6	TXD+	O	Balanced Transmit Data (+)
7	DTR	O	Data Terminal Ready
8	RXD+	I	Balanced Receive Data (+)

**Table 1-17. X-On/X-Off and DTR Status**

State	Buffer Space	X-ON/X-OFF	DTR
Busy	Less than 3072 bytes	Send X-OFF code	OFF
Ready	More than 5120 bytes	Send X-ON code	ON

### 1.3.3.1 USB Interface (Only for Stylus Color 740)

[Standard] Universal Serial Bus Specifications Rev. 1.0  
 Universal Serial Bus Device Class Definition  
 for Printing Device Version 1.0  
 [Bit Rate] 12 M bps  
 [Data Encoding] NRZI  
 [Connector] USB Series B  
 [Recommended Cable Length] 2 meters

**Table 1-18. Pin Assignment**

Pin No.	Signal Name	I/O	Description
1	Vcc	----	Cable power, Maxi. power consumption is 100 mA
2	-Data	Bi-D	Data
3	+Data	Bi-D	Data, pull up to +3.3 V via 1.5 K ohms resistor
4	Ground	----	Cable Ground

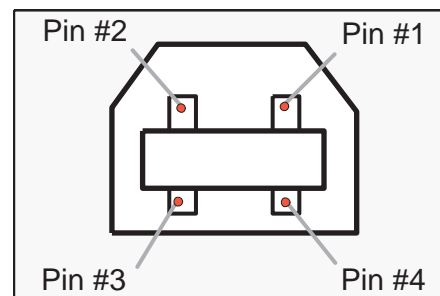

**Figure 1-10. USB Pin Assignment**

## 1.4 Control Panel

Since Stylus Color 440, 640, 740 does not require many buttons since printer driver can start various settings and motions. Therefore, there are only 2 non-lock type push switches, 1 lock type push switch and 4 LEDs. Figure 1-11 shows control panel of Stylus Color 440/640/740.

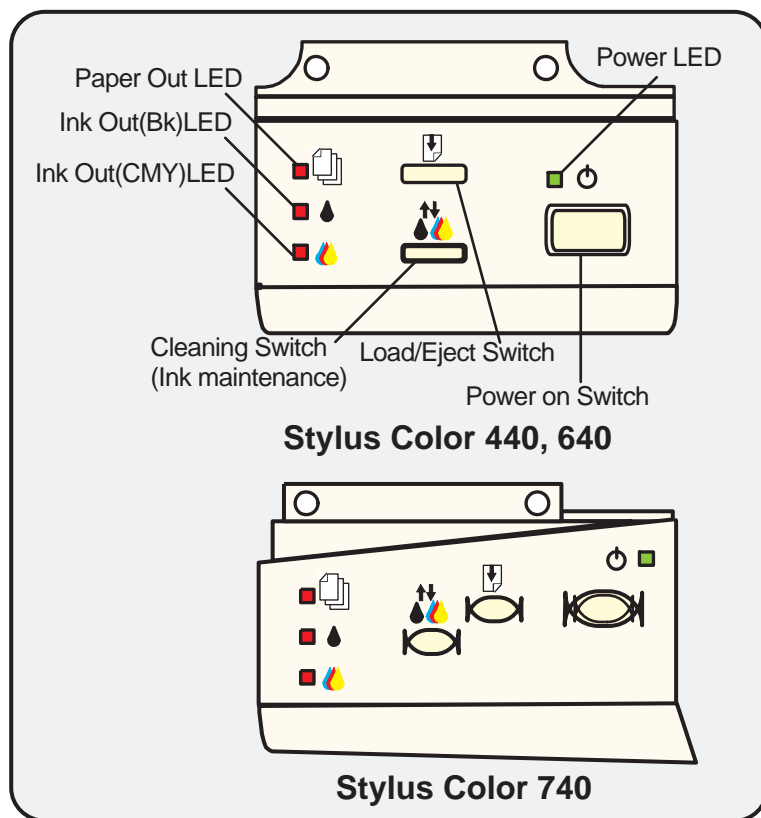

Figure 1-11. Control Panel Over Viewing

### 1.4.1 Indicators (LEDs)

- (1) **Power**  
Lights when the operate switch is "ON", and AC power is supplied.
- (2) **Paper out**  
Lights during the paper-out condition, and blinks during the paper-jam condition.
- (3) **Ink Out (Black)**  
Lights during no Black ink condition, and blinks during the Black ink low condition.
- (4) **Ink Out (Color)**  
Lights during no Color ink condition, and blinks during the Color ink low condition.



## 1.4.2 Panel Functions

Refer to Table 1-19 to Table 1-21.

**Table 1-19. Panel Functions**

Switch	Function
Load/Eject (within 2 sec.)	1. Loads or ejects a paper. 2. When the carriage is on the I/C replacement position, return the carriage to the capping position.
Load/Eject (for 2 sec.)	1. Starts the I/C replacement sequence.
Cleaning (for 2 sec.)	1. Starts the printhead cleaning sequence. 2. In case it's in the ink low or ink out condition, starts the I/C replacement sequence.
Cleaning (within 2 sec.)	1. When carriage is on the I/C replacement position, return the carriage to the capping position.

**Table 1-20. Panel Function with Power On**

Switch	Function
Load/Eject	1) Starts the status print. (*1)
Cleaning	<Stylus Color 440, 640> Changes the code page. (*2) <Stylus Color 740> Enters the Default setting mode. (*3)
Load/Eject + Cleaning	Enters the EEPROM Reset mode. (The Load/Eject LED blinks for a few seconds.) (Used only for resetting the maintenance error.) (*4)

**NOTE 1:** You can check the 1) firmware version, 2) protection counter and 3) nozzle check pattern by performing this function.

**NOTE 2:** The code pages for Stylus Color 440, 640 are not opened.

**NOTE 3:** Since Stylus Color 740 have 2 specifications both the standard and NLSP version, user can select some parameter and a character table by communicating with the printed list.

**NOTE 4:** After you enter this EEPROM reset mode, go to Table 1-21.

**Table 1-21. EEPROM Reset**

Switch	Function
Cleaning	Resets the EEPROM. (*5) 1. While the Load/Eject LED is blinking (for about 2 seconds), press down the Cleaning switch for 10 seconds.  The following steps vary depending on the printer. 2. [Stylus Color 440/640] After 10 seconds, both Bk and CMY ink LEDs come <b>ON</b> simultaneously. [Stylus Color 740] After 10 seconds, Load/Eject, Bk and CMY ink LEDs all <b>blink</b> simultaneously. 3. [Stylus Color 440/640] Confirming the both LEDs are <b>ON</b> , release the Cleaning switch. The printer automatically starts initialization operation to reset the specified addresses in the EEPROM. [Stylus Color 740] Confirming all 3 LEDs are <b>blinking</b> , release the Cleaning switch. The printer automatically starts initialization operation to reset the specified addresses in the EEPROM.

**NOTE 5:** Before you press the Load / Eject switch, be sure to enter the EEPROM reset mode, referring to Table 1-20.



You can reset the below addresses in a EEPROM by performing the EEPROM Reset operation.

- 1) Timer Counter (Power Off time) IC value
- I/F selection returns to Auto
- Protection Counter value



Even though you repeat the EEPROM reset operation, it does not perform initialization but only resets the EEPROM addresses. Whether or not to perform initialization depends on the power off time monitored by the timer IC.

### 1.4.3 Printer Condition and Panel Status

Table 1-22 shows printer condition and panel status. Since the table shows various error status and also indicates printer status, it enables you to find appropriate repair ways.

**Table 1-22. Printer Condition and LED Status**

Printer Status	Indicators				Priority
	Power	Ink Out (Black)	Ink Out (CMY)	Paper Out	
Power on condition	---	---	---	---	9
Ink Sequence mode	On	---	---	---	6
I/C replacement mode	Blink	---	---	---	5
Data processing	Blink	---	---	---	8
Paper out	Blink	---	---	On	4
Paper jam	---	Off	Off	Blink	3
No I/C, Ink out (bk)	---	On	---	---	7
Ink level low (bk)	---	Blink	---	---	7
No I/C, Ink out (CMY)	---	---	On	---	7
Ink level low (CMY)	---	---	Blink	---	7
Enters the EEPROM Reset	---	ON (for 3 seconds)			---
Maintenance Request	Blink	Blink	Blink	Blink	2
Fatal Error	Blink	On	On	Blink	1

## 1.5 Error Status

---

When following status occur, the printer goes to the error status and stops taking data, setting the /ERROR signal in the interface as “Low”, and Busy signal as “High”. At this time, the printer goes to non printable status. Refer to Section 1.4.3 for more details of LED Panel indicators during the various error status.

### 1.5.1 Ink Out

When the printer runs out the most part of the ink of any one color, it warns ink-low and keeps printing. When the printer runs out the whole ink of any one color, it stops printing and indicates ink-out error. User is requested to install a new ink-cartridge in this state. A ink-cartridge once taken out should never be used again. Re-installation of the cartridge not filled fully upsets the ink level detection and may cause a serious problem in the print head as a result.



**Never use the ink cartridge that has been removed.**

The following explains the warning sign above.

#### [Step 1]

After the cartridge is once taken out, bubbles come in from the ink supply hole located at the top of cartridge and are absorbed into the head during printing. AS a result, the head is unable to discharge ink properly. Also, inevitable entry of bubbles created during installation of a new ink cartridge can be absorbed to ink itself since the ink in the cartridge is deaerated during the production process. However, this ability for absorption can last only about one hour after the cartridge is installed.

#### [Step 2]

Even after the bubble absorbing ability described above stops, there is problem about entering bubbles as long as the ink cartridge is installed in the printer. However, if the ink cartridge which does not have absorbing ability any more is once removed from the printer, new coming bubbles into the cartridge will never disappear naturally. These bubbles may cause not only printing malfunction but also thickening ink. This thickened ink goes into the head and clogs ink path in the head or nozzle and may cause serious head damage.

#### [Step 3]

As standard specification for Stylus Color 400, ink consumption counter is reset when the ink cartridge is removed. If an ink cartridge is removed and re-installed unnecessarily the value on the ink consumption monitor which the user can check will be wrong and printer may keep printing even though the ink cartridge is installed empty. This may cause head damage.

### 1.5.2 Paper Out

When the printer fails to load a sheet after power on operation including timer-cleaning is done and Load/Eject button on the FF command or operation panel is pressed, it goes into a paper out error.

### 1.5.3 Paper Jam

When the printer fails to eject a sheet even after feeding motion is completed or Load/Eject button on the FF command or operation panel is pressed, it goes into a paper jam error.

## 1.5.4 No Ink-Cartridge

Following reasons can be the causes when printer goes this error mode.

1. When the printer is turned on for the first time. (This is a normal error state and it returns to the normal state after installing an ink cartridge according to the ink cartridge exchange operation.)
2. Ink cartridge exchange operation is done correctly. After the position of carriage is moved by exchange operation, if the cleaning switch is pushed without installing ink cartridge or if the carriage returns to the home-position automatically without doing any operation, it is considered as handling mistake. However, it returns to normal state by performing ink exchange operation again and installing cartridge correctly.
3. If “No ink-cartridge error” appears even after the ink cartridge is installed, the printer must be something wrong and around the sensor area in the carriage need to be repaired.
4. If sometimes printer can print normally but also sometimes “No ink-cartridge error” appears, the printer must be something wrong. (Same reason as above)

## 1.5.5 Maintenance Request

When the total quantity of ink wasted through the cleanings and flushing reaches to the limit, printer indicates this error and stops. The absorber in the printer enclosure is needed to be replaced with new one by a service person. The ink quantity that is absorbed by the absorber (waste ink pad) is monitored by the software counter as “total ink counter”. This counter is added by point system and absorber’s maximum ability is set at the following reference value.

<b>Stylus Color 440 Maximum Counter Point:</b>	<b>21000 Point</b>
<b>Stylus Color 640 Maximum Counter Point:</b>	<b>19800 Point</b>
<b>Stylus Color 740 Maximum Counter Point:</b>	<b>40900 Point</b>

*NOTE: Since 1 point of counter point equals 0.02 ml, the actual ink amount becomes;*

<b>Stylus Color 440 Maximum Ink Capacity:</b>	<b>420 ml</b>
<b>Stylus Color 640 Maximum Ink Capacity:</b>	<b>396 ml</b>
<b>Stylus Color 740 Maximum Ink Capacity:</b>	<b>818 ml</b>

## 1.5.6 Fatal Errors

When the printer detects fatal errors such as carriage control error or CG access error, it enters a fatal error mode, as described below.

### 1) Carriage control Error:

- Parallel adjustment malfunction
- Home-position malfunction
- Timing belt tension malfunction, shortage of lubricant on the carriage guide shaft, etc.

### 2) CG Access Error:

- Short circuit, etc.

## 1.6 Printer Initialization

---

Stylus Color 440, 640, 740 have three kinds of initialization methods. Following explains each initialization.

### [1.Power-on initialization]

This printer is initialized when turning the printer power on, or printer recognized the cold-reset command (remote RS command). When printer is initialized, following action is performed.

- (a) Initializes printer mechanism.
- (b) Clears input data buffer.
- (c) Clears print buffer.
- (d) Sets default values.

### [2.Operator initialization]

This printer is initialized when turning the printer power on again within 10 seconds from last power off, or printer recognize the /INIT signal (negative pulse) of parallel interface. When printer is initialized, following action is performed.

- (a) Cap the printer head.
- (b) Eject a paper.
- (c) Clears input data buffer.
- (d) Clears print buffer.
- (e) Sets default values.

### [3. Software initialization]

The ESC@ command also initialize the printer. When printer is initialized, following action is performed.

- (a) Clears print buffer.
- (b) Sets default values.

## 1.7 Initialization Settings

---

Stylus Color 440, 640, 740 initializes following settings when the initialization is performed. Also, if the user changes the settings in the Panel setting mode, Default setting or Remote command setting, values or settings which are possible to be stored are initialized as initialization settings.

- Page position: Page heading location for current page
- Line spacing: 1/6 inch
- Right margin position: 80 lines
- Left margin position: First line
- Character pitch: 10CPI
- Printing mode: Text mode (Not Raster graphics mode)

## 1.8 Main Components

---

Stylus Color 440, 640, 740 have following major units. Also, it is one of the major characteristics that the bottom of the Printer mechanism serves as the Lower case at the same time. Each unit from 2) to 5) are simply explained below:

- 1) Upper Case
- 2) Printer Mechanism
- 3) Main Control Board
  - Stylus Color 440:C206 Main-B Board, C255 Main Board
  - Stylus Color 640:C256 Main Board
  - Stylus Color 740:C257 Main Board
- 4) Power Supply Board
  - Stylus Color 440:C206 PSB/PSE Board
  - Stylus Color 640:C206 PSB/PSE Board
  - Stylus Color 740:C257 PSB/PSE Board
- 5) Control Panel Board
  - Stylus Color 440:C206 PNL Board
  - Stylus Color 640:C206 PNL Board
  - Stylus Color 740:C209 PNL Board

### 1.8.1 Printer Mechanism

Like the previous printer mechanism such as for Stylus Color 400, 600, and Stylus Photo, one of the major characteristics of Stylus Color 440, 640, 740 is that the printers have no Engage/Disengage mechanism to change between the pump mechanism and paper feeding mechanism. In stead, this change-over control is done by the distinction between turning direction of PF/Pump motor and position of present carriage unit. Also, another major characteristic is that printhead is on unit combining black and color.

### 1.8.2 C206 Main-B Board (Stylus Color 440)

C206 Main-B board controls Stylus Color 440 and consists of following major electric elements. This board will be changed to new board called C255 Main board.

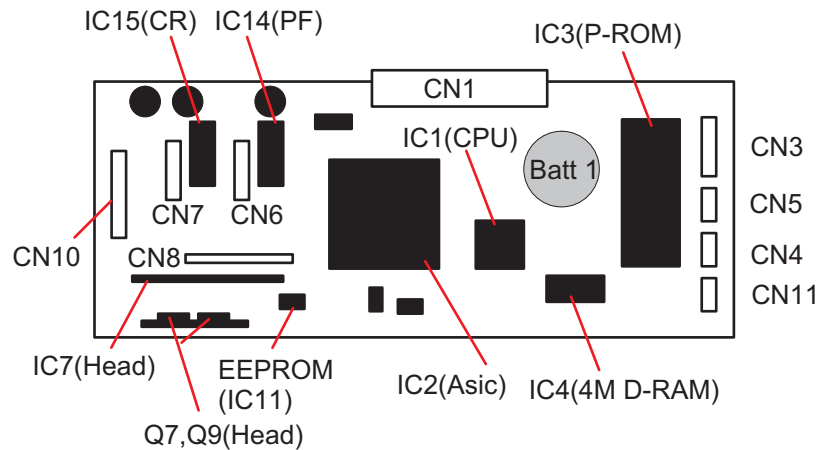

Figure 1-12. C206 Main-B Major Electric Elements

### 1.8.3 C256 Main Board (Stylus Color 640)

C256 Main board controls Stylus Color 640 and consists of following major electric elements.

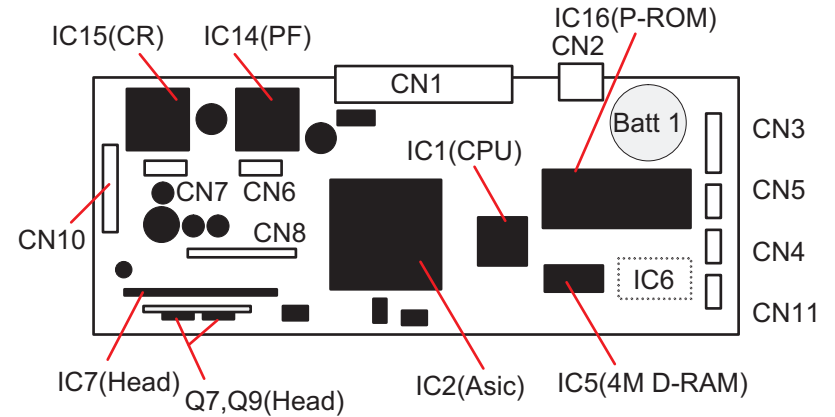

Figure 1-13. C256 Main Board Major Electric Elements

### 1.8.4 C257 Main Board (Stylus Color 740)

C257 Main board controls Stylus Color 640 and consists of following major electric elements.

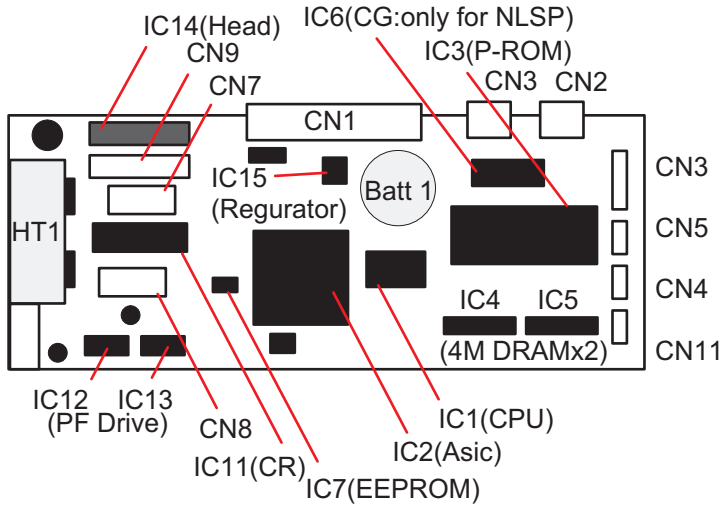

Figure 1-14. C257 Main Board Major Electric Elements

### 1.8.5 Power Supply Board C206 PSB/PSE (Stylus Color 440, 640) C257 PSB/PSE (Stylus Color 740)

In the electric boards for Stylus Color 440, 640, 740, a switching regulator method is used and supplies stable logic and power voltages constantly. Also, since this C206/C257 PSB board has a secondary type switch for its circuit system, it is possible to keep supplying electricity to the C206main-B/C255/C256/C257 main control board for 30 seconds even after the power switch is turned off. Using this time difference, even when mis-operation is done by the user such as turning off the power during the middle of printing work, it prevents thickened ink from attaching around the nozzle plate by transferring the head to cap position.

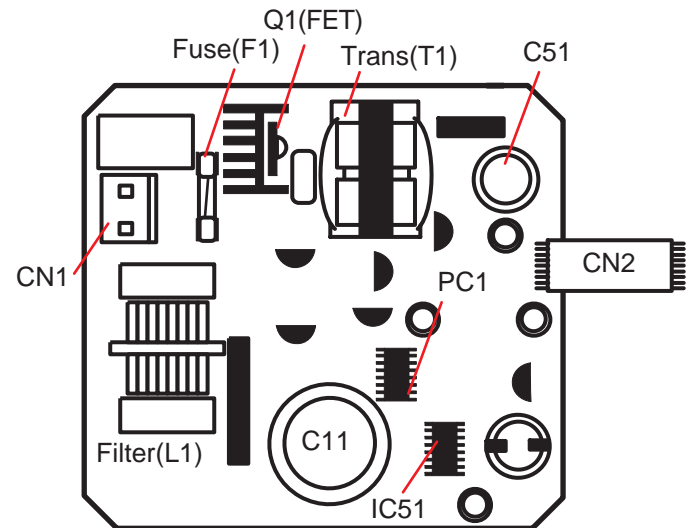

Figure 1-15. C206/C257 PSB/PSE Board Major Electric Elements



### 1.8.6 C206 PNL Board (Stylus Color 440, 640)

Panel board (C206 PNL board) is located in the panel case where is in the right bottom of the front printer and consists of 3 switches, 4 LEDs and 1 connector.

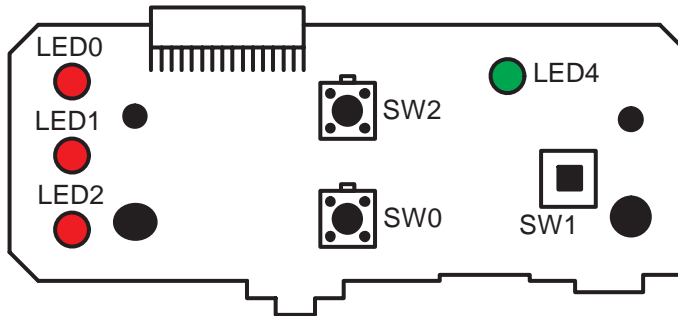

Figure 1-16. C206 PNL Board

### 1.8.7 C209 PNL Board (Stylus Color 740)

Panel board (C209 PNL board) is located in the panel case where is in the right bottom of the front printer and consists of 3 switches, 4 LEDs and 1 connector.

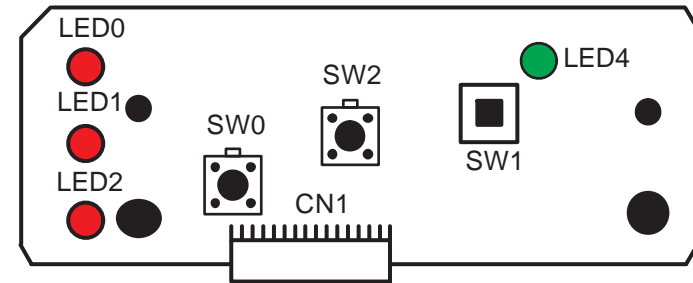

Figure 1-17. C209 PNL Board

**CHAPTER**

**2**

**OPERATING PRINCIPLES**

## 2.1 Overview

---

This section describes the operating principles of the printer mechanism and the electric circuit board.

- Electronic Boards for Stylus Color 440 are;
  - Main: C206 Main-B, C255 Main Board
  - Power Supply: C206 PSB,PSE Board
  - Panel: C206 PNL Board
  
- Electronic Boards for Stylus Color 640 are;
  - Main: C256 Main Board
  - Power Supply: C206 PSB,PSE Board
  - Panel: C206 PNL Board
  
- Electronic Boards for Stylus Color 740 are;
  - Main: C257 Main Board
  - Power Supply: C257 PSB,PSE Board
  - Panel: C209 PNL Board

## 2.1.1 Printer Mechanism

Like previous EPSON Ink Jet printers such as Stylus Color 400, 600, Photo, Photo 700, Photo EX, the printer mechanism of Stylus Color 440/640/740 does not have an exclusive mechanism to change over paper feeding and pumping operation. In stead, this control is done by the turning direction of paper feed/pump motor and position of the carriage at that time. Also, the print heads of these printers combine the black and CMY heads in one unit. The followings indicate the nozzle configurations of these 3 models.

- Stylus Color 440:  
 Black Nozzle: 64 nozzles(90 dpi x 2 rows in staggered)  
 CMY Nozzle: 21 nozzles/colors(90 dpi x 1 row)
- Stylus Color 640:  
 Black Nozzle: 64 nozzles(90 dpi x 2 rows in staggered)  
 CMY Nozzle: 32 nozzles/colors(90 dpi x 1 row)
- Stylus Color 740:  
 Black Nozzle: 144 nozzles(120 dpi x 3 rows in staggered)  
 CMY Nozzle: 48 nozzles/colors(120 dpi x 1 row)

Among these printers, the Stylus Color 640 and 740 can print 1440 (H) x 720(V) resolution like Stylus Color 800 and Pro5000. On the other hand, the Stylus Color 440 can print real 720 dpi(720 (H) x 720(V)) resolution like Stylus Pro XL.

Figure 2-1 in the in the right column shows the outline of the printer mechanism.

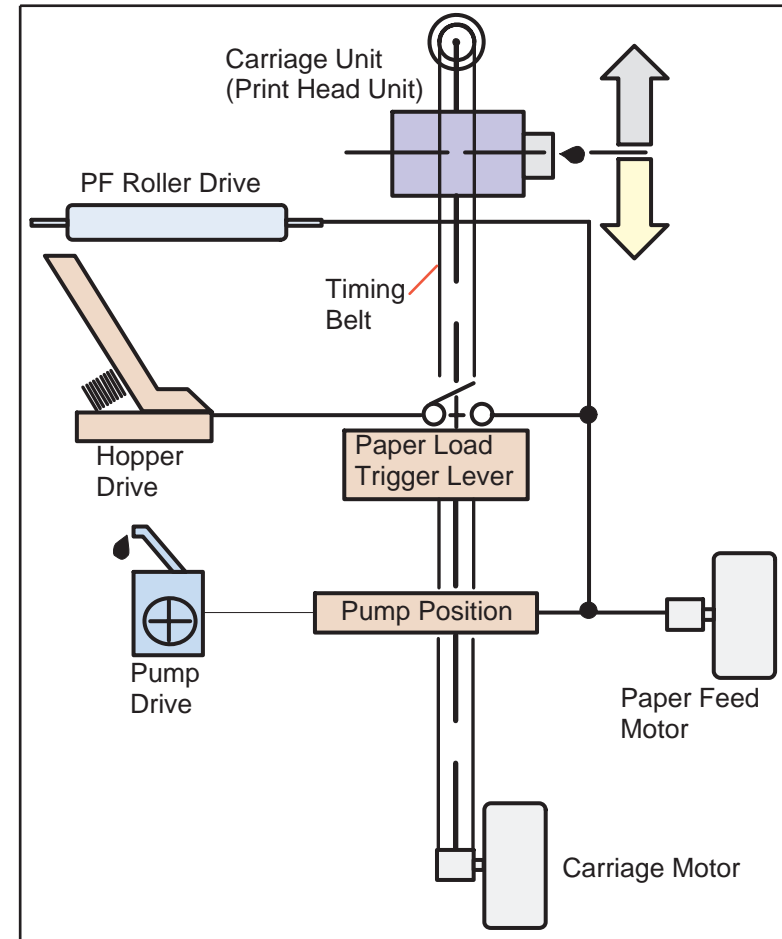

Figure 2-1. Printer Mechanism Block Diagram

### 2.1.1.1 Printing Mechanism

Basic principles of the print head which plays major role of printing mechanism is the same as previous models; on demand type MACH head method, but there is some difference in the resolution. (Refer to figure1-1)

Also, unlike Stylus Color IIs, 820, 200 automatic correction type, in order to fix the dispersion of multi layer piezo electric element which is used for driving each nozzles, it is necessary to input the VH value written on the side of print head by using exclusive program when you replace print head, control board, or the printer mechanism. (However, there are no resistor array to decide the VH voltage on the main control board.) Following explains print head.

- PZT
 

PZT is an abbreviation of Piezo Electric Element. Print signal from the PSB/PSE board is sent through the driver board on the print head unit and to the PZT. Then, the PZT pushes the top cavity which has ink stored, and make the ink discharge from each nozzle located on the nozzle plate.
- Cavity Set
 

Ink which is absorbed from ink cartridge go through the filter and will be stored temporarily in this tank, which is called "cavity" until PZT is driven.
- Nozzle Plate
 

The board with nozzle holes on the printer head surface is called Nozzle Plate.
- Filter
 

When the ink cartridge is installed, if any dirt or dust around the cartridge needles are absorbed into the head inside, there is a great possibility of causing nozzle clog and disturbance of ink flow and finally causing alignment failure and dot-missing. In order to prevent this, filter is set at cartridge needle below and ink is once filtered here.

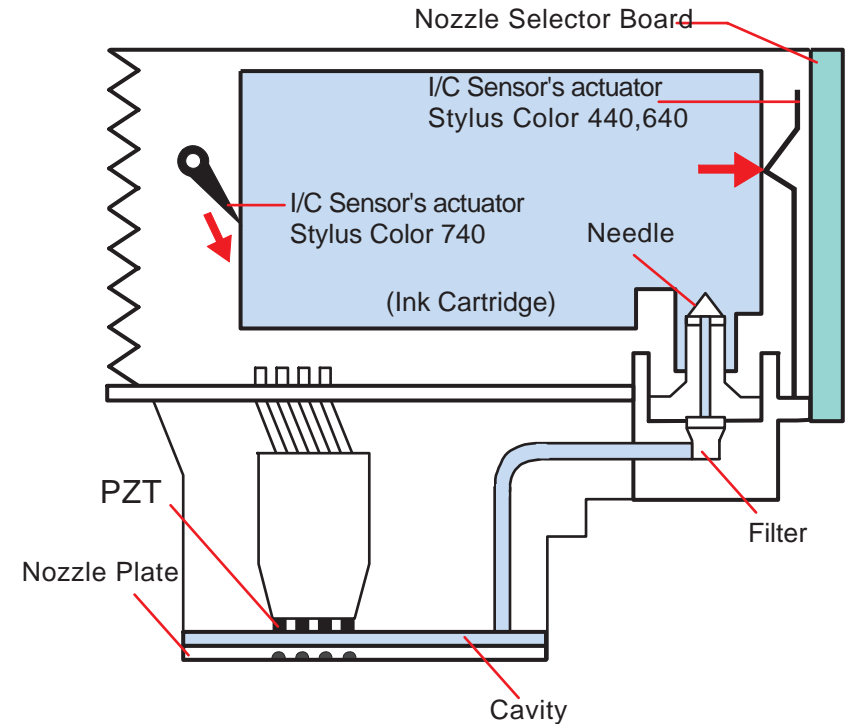

Figure 2-2. Print Head Sectional Drawing

### 2.1.1.2 Printing Process

Following figures show the sectional drawings of normal state and ejecting state of the printhead.

#### 1. Normal State:

When the print signal is not output, PZT also does not move in the waiting state (normal state). (Refer to Figure 2-3.)

#### 2. Ejecting State:

When the print signal is output from the C206 main-B/C255/C256/C257 main board, IC (IR2C72C:Nozzle Selector) located on the Print head unit latches the data once by 1-byte unit. Appropriate PZT latched by nozzle selector is pushed into the cavity by applying common voltage from the main board. By this operation, ink that is stored in the cavity pops out from nozzles. (Refer to figure 2-4.)

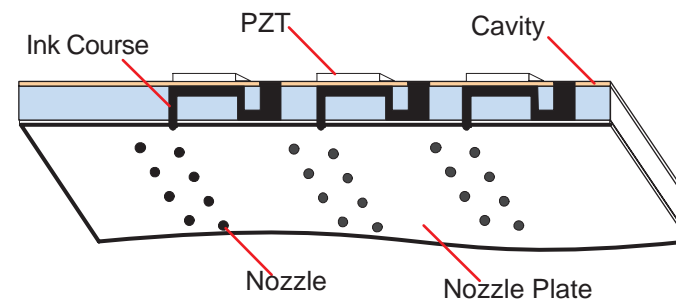

Figure 2-3. Print Head Normal State

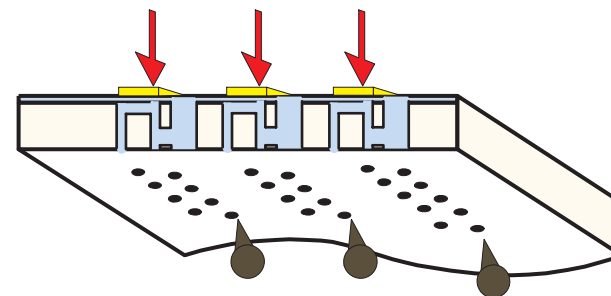

Figure 2-4. Print Head Ejecting State

### 2.1.1.3 Carriage Mechanism

Carriage mechanism is to drive the carriage with print head mounted from left to right or vice versa. The carriage drive motor in these printers are a 4-phase, 200-pole, stepping motor and is driven by 1-2 phase, 2-2 phase and W1-2 phase drive method for Stylus Color 440, 460, and by 2-2 phase 1-2 phase, W1-2 phase, 2W1-2 phase and 4W1-2 phase drive method for Stylus Color 740. This stepping motor allows the carriage to move freely to the particular positions which is necessary for various operation, such as paper feeding, ink absorbing, flashing, ink exchange and cleaning operations. The tables below show carriage motor specifications and motor controls at each mode.

**Table 2-1. Carriage Motor Specifications**

Items	Description
Motor type	4-Phase/200-pole Stepping motor
Drive voltage Range	42VDC $\pm$ 5%
Internal coil resistance	7.8 Ohms $\pm$ 10%(per phase under 25 °C environment)
Driving Speed(frequency) Range[csp(Hz)]	5(60)~340(4080)
Control method	Bi-Pola Drive

**Table 2-2. Motor Control at Each Modes (Stylus Color 440, 640)**

Printing mode	Drive Speed [CPS]	Drive frequency [PPS]	Drive method
High Speed Skip	340	4080	W1-2, 2-2,1-2 phase drive*
Normal Printing	200	2400	W1-2, 2-2 phase drive
Capping	80	960	W1-2, 2-2 phase drive
Wiping	40	480	W1-2, 2-2 phase drive
Cap (Valve Release)	20	240	W1-2, 2-2 phase drive
Withdrawal of cap	5	60	W1-2, 2-2 phase drive

**Table 2-3. Motor Control at Each Modes (Stylus Color 740)**

Printing mode	Drive Speed [CPS]	Drive frequency [PPS]	Drive method
High Speed Skip	340	4080	W1-2, 2-2,1-2 phase drive*
Normal Printing	200	2400	W1-2, 2-2 phase drive
Capping	80	960	2W1-2, 2-2 phase drive
Wiping	40	480	2W1-2, 2-2 phase drive
Cap (Valve Release)	20	240	4W1-2, 2-2 phase drive
Withdrawal of cap	5	60	4W1-2, 2-2 phase drive

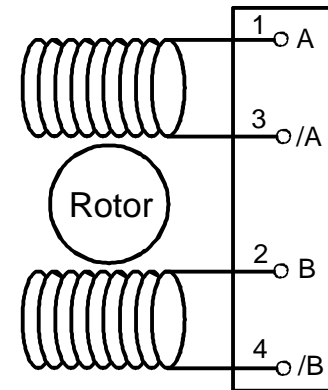

**Figure 2-5. CR (PF) Motor Internal Circuit Diagram**

See Figure 2-6 which shows the carriage mechanism.

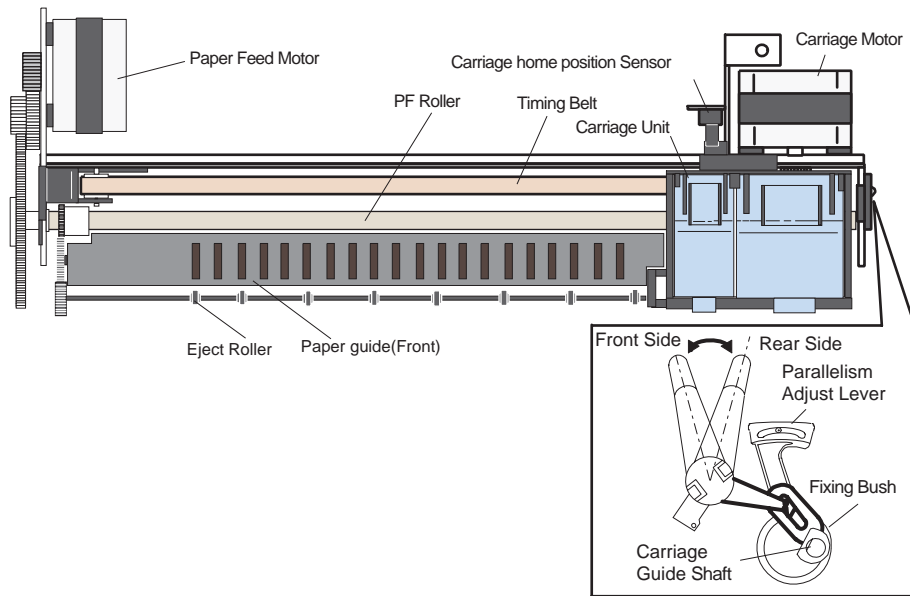

**Figure 2-6. Carriage Mechanism (Top view)**

The printhead, a core of the printing mechanism, is stored in the carriage unit. When the adjustment lever is moved up and down, this printhead maintains the printhead tilt in a flexible and adjustable structure, using a tilt adjustment mechanism. Also, the parallelism adjustment lever, mounted on the left and right sides of the carriage guide shaft, adjusts parallelism between the platen and shaft when the shaft is installed to the printer mechanism. After this adjustment is completed, moving PG adjustment lever changes space between the platen surface and the print head surface to one of two possibilities: either 1.04 mm or 1.74mm. It is possible to vary the space between platen surface and print head by rotating the shafts of the carriage guide shaft which itself is decentralized, with the operation of PG lever. This is the mechanism that the user can use to adjust the appropriate PG value

according to the printing result or any other environmental conditions such as paper curl.

Carriage lock mechanism is to prevent the carriage from being left at an uncapped position for a long time because of vibration during the printer transport or mishandling by the users. If the carriage is left uncapped for long time, ink on the print head surface gradually becomes thick. As a result, the nozzle will be unable to discharge ink.

To make matters worse, the holes (crater) of nozzle may be completely clogged by the thick ink and it may not be able to return to the normal condition just by cleaning operation. In order to prevent this, printer goes to carriage lock state at the following conditions. (See the following page.)

**After Power OFF operation:**

If the power is turned off on the way of printing or any other performance, carriage lock will be performed in the end after completing initialize operation.

**After power ON operation:**

After power is turned on and automatic P-On Cleaning is performed, then carriage lock will be performed. P-On Cleaning is an automatic head cleaning that is performed when the power is turned on. The timer IC always calculates printer's power OFF time by the power of lithium battery mounted on the C206 Main-B/C255/C256/C257 Main board. P-on cleaning function automatically selects the cleaning level according to the time which the printer is not in used.

**After Eject the paper:**

After Load/Eject button is pressed and the paper is ejected, if the data is not input, the printer performs carriage lock and goes to standby state. However, if the paper is loaded to the printer inside by Load/Eject button, the printer does not perform carriage lock operation.



### 2.1.1.3.1 Platen Gap Adjust Mechanism and Parallel adjustment Mechanism

This mechanism can be set by the users and can prevent various problems related to low image density or print with any dirt by changing the positions of PG lever according to the paper types.

**Table 2-4. Platen Gap Adjust Lever Setting**

Paper	Lever Position	PG adjustment value
All Media	Front	0 mm (1.04mm between head and platen)
If you find any print problems	Rear	0.7mm (1.07mm between head and platen)

It is a major premise that parallel adjustment is done correctly for the space between head and platen (PG adjustment value above) which can be changed by platen gap adjustment. Parallel adjustment should be done when the serviceman mounts the carriage guide shaft on the printer mechanism during the production process or repair service. In the adjustment, the space between parallel adjustment lever and gage should be 1.04 mm.

### 2.1.1.4 Paper Feed Mechanism and Pump Mechanism

Mechanisms that send the paper in the hopper to inside the printer and perform constant paper feed in order to perform printing on the sent paper are called paper feed mechanism as generic name. In the Stylus Color 440/640/740, 4 phase hybrid type pulse motor is used in the PF motor as a motive power motor as a motive power of the paper mechanism and driving is done at 2-2, 1-2 phase drive method for Stylus Color 440, 640 and at 2W1-2, W1-2, 1-2 and 2-2 phase drive method for Stylus Color 740. This motor is not only used as a power source for paper feed mechanism but also used as power source of pump mechanism which is necessary for print head cleaning. By using this pulse motor, it becomes possible to use high speed driver or intermittent drive for the various paper feeds and pump operations such as paper feed, slight paper feed, high and low speed absorption of pump operations. Following tables show PF motor specifications and control method at each mode.

**Table 2-5. PF Motor Specifications (Stylus Color 440, 640)**

Item	Description
Motor type	4-phase/48-pole Stepping motor
Drive voltage	42VDC $\pm$ 5%
Coil Resistance	7 Ohms $\pm$ 10%(per 1 phase under 25°C environment)
Drive frequency [Hz]	100-1990 Hz
Control method	Bi-Pola Drive

**Table 2-6. PF Motor Specifications (Stylus Color 740)**

Item	Description
Motor type	4-phase/200-pole Stepping motor
Drive voltage	42VDC $\pm$ 5%
Coil Resistance	8.8hms $\pm$ 10%(per 1 phase under 25°C environment)
Drive frequency [Hz]	100-3240 Hz
Control method	Bi-Pola Drive

Papers on the ASF (auto-sheet-feeder) supplied by the user are carried to the printer inside by paper pick up sequence. Unlike the previous models, ASF of Stylus Color 440/640/740 has multi feed prevention mechanism. Following explains this function and figure below shows its mechanism.

### [1. Multi-feed prevention mechanism]

When the Load/Eject button is pressed, reversed rotation of PF motor is performed. The return lever resets papers which are already in the out of stand by position in the stand by position and make it possible to perform stable paper feeding by picking up the paper again. Following explains process of multi-feed prevention step by step. Refer to the figure above and confirm its operation.

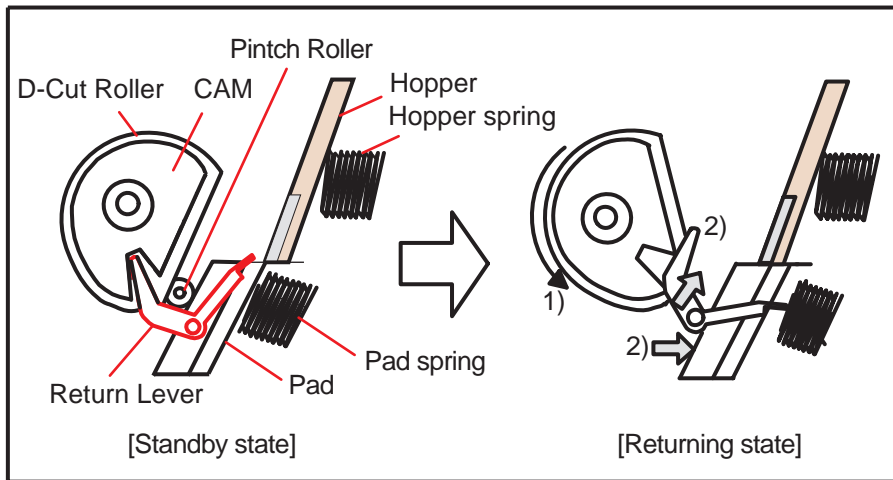

Figure 2-7. ASF Unit Operation

### [Step 1]

When the load/Eject switch is pressed or printing order is input from the PC, PF motor rotates counterclockwise and makes the CAM rotate towards direction of 1 in the figure above.

### [Step 2]

When the CAM covers the notch by the return lever, that position is considered as home position, being monitored by ASF sensor.

### [Step 3]

When the CAM rotates toward 1 in the figure above, the return lever is pushed by the notch of CAM and falls towards 2. At this time, the return lever moves to direction 3 by this motion, and push down the pad which is waiting in the below part. At this time, friction of pinch roller and pad will be canceled.

### [Step 4]

The papers which are out of stand by position by the previous paper feed motion are returned to the paper stand by position by flip over strength of return lever. After this, PF motor rotates clockwise and the printer goes to pick up sequence.

In the paper pick up mechanism of Stylus Color 440/640/740, same mechanism as Stylus Color 400, 600, Photo, Photo EX are applied. This mechanism changes adjoined lines of gear by colliding trigger lever with carriage unit and convey the motive power on the platen to the ASF side (paper roller). The figure below shows mechanism with explanation.

**[2. Paper pick up mechanism]**

When the Load/Eject switch is pressed or printing order is input, the carriage unit moves until the left edge and collides with paper pick up trigger lever. When the carriage collides with this trigger level, a planetary gear located on the same axis is also pushed at the same time and conveys the motive power on the platen to the adjoined gear line side for ASF drive.

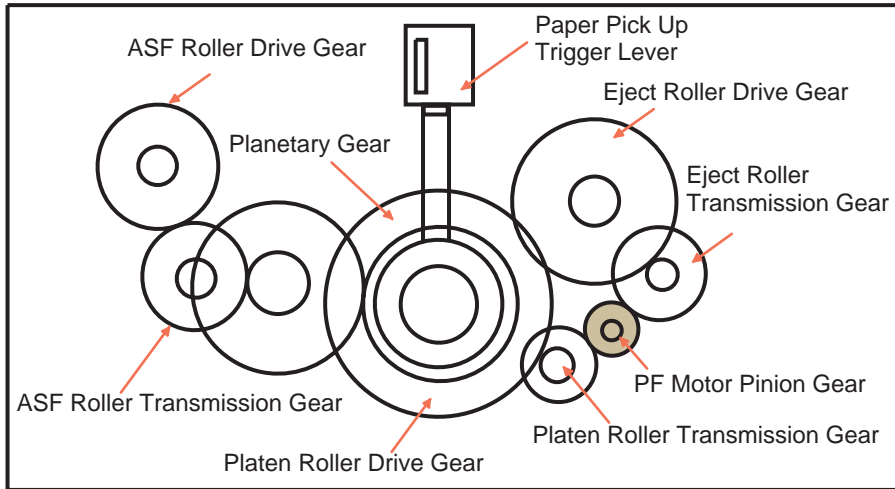
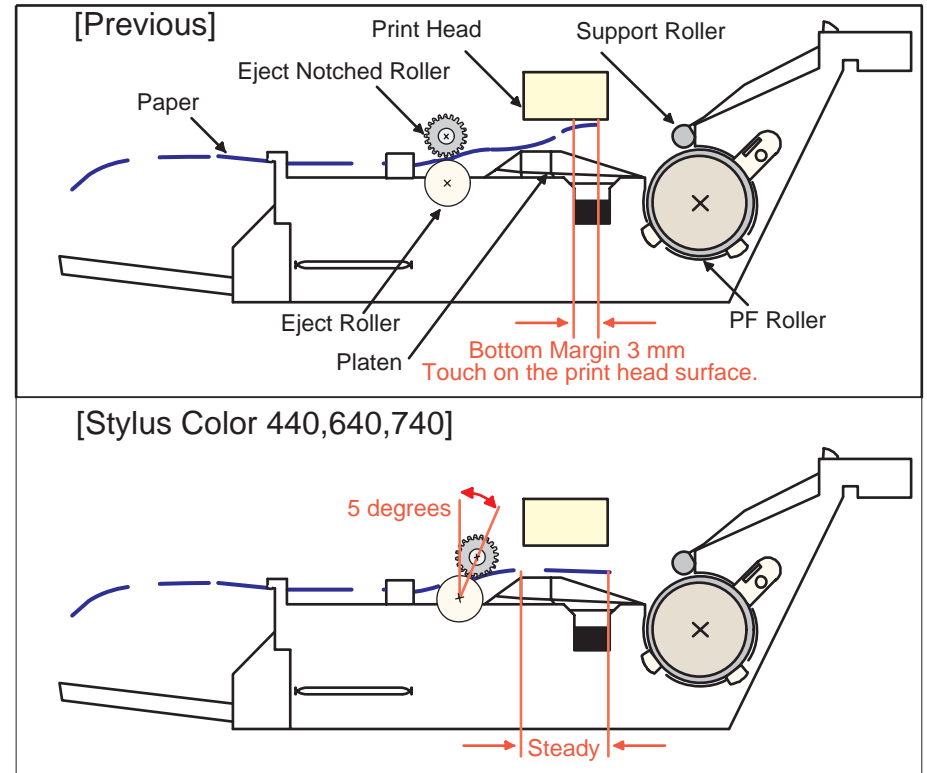

**Figure 2-8. Paper Pick up Mechanism**

**[3. Paper feed mechanism]**

After papers in the ASF receive controls from pick up and multi feed prevention mechanism, they are sent to the printer inside. The papers picked up by paper roller in the ASF goes to between platen and roller support. Also, the eject roller pushes out the paper completely until the end and the roller support drops the paper in the eject tray. The eject roller is driven with an eject paper notched roller as pair where is located on the paper eject roller.

Paper eject notched roller solves the deflection of paper that is in the between platen eject notched roller and paper eject roller and always keep a certain space between print head and paper surface. For an unique point, the securing angle of Eject Notched Roller has been changed by 5 degrees compared with the previous products. Due to this change, the bottom margins of these printers are expanded from 14 mm to 3 mm.



**Figure 2-9. Paper Feed Mechanism**

### 2.1.1.5 Ink System

Ink system mechanism consists of 1)cap mechanism, 2)pump mechanism, carriage lock mechanism, 4)waste ink absorber and 5)ink sequence. Out of these mechanism, from 1) to 4) are physical mechanism and parts which are mounted on the printer mechanism and 5) ink sequence is performed automatically by firmware. Also, unlike previous models, since Stylus Color 440/640/740 has no engage/disengage mechanism to change over pump mechanism and paper feed mechanism, it is one of the major characteristics that pump and platen are always at work whenever the PF motor is driven. The figure below shows head positions when the ink system and various ink sequence are performed.

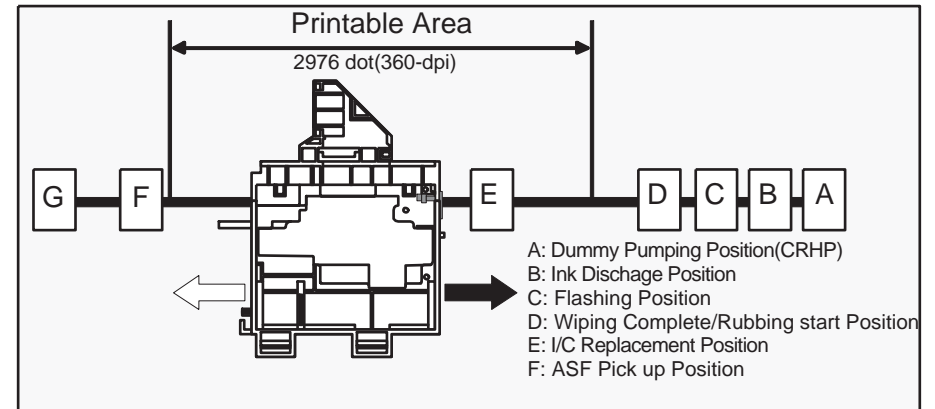

**Figure 2-11.**  
Major Ink Sequence Position on Carriage Working Area

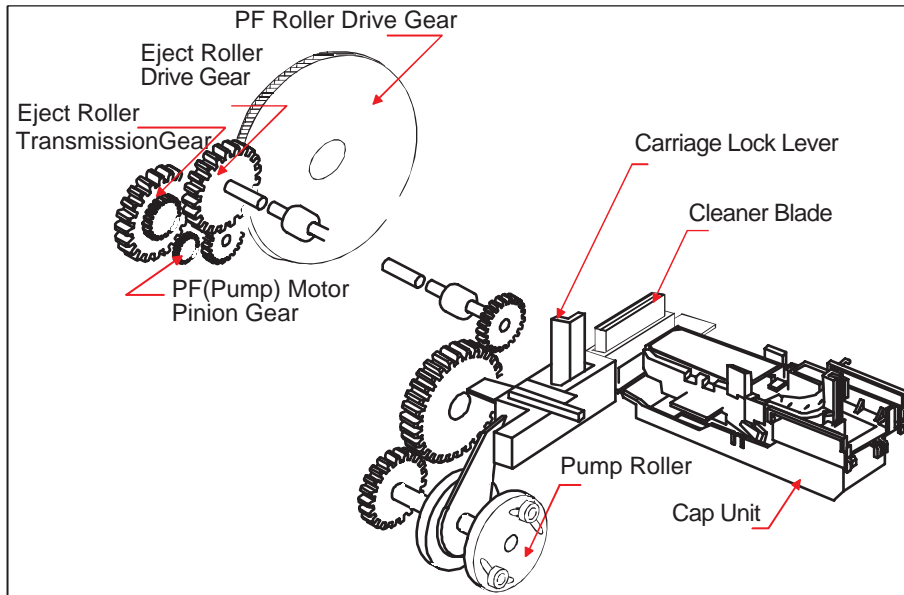

**Figure 2-10.** Ink System Mechanism

### 2.1.1.6 Pump, Carriage Lock, Head Cleaner Mechanism

In the Stylus Color 440/640/740, there is no switch or mechanism to change over the pump/paper feed mechanism. Therefore, whenever the paper feed/pump motor rotate, pump drive roller in the pump unit inside rotates. However, ink absorption/non ink absorption are separated by the roller rotational direction. Also, even if the pump driver rotates toward ink absorption and the carriage position is in the false absorption position, only driving in the pump mechanism is performed and actual ink attraction is not done. Figure 5-2 shows process of conveying motive power to the pump drive roller.

See Figure 1-12. The process of conveying the motive power to the paper eject roller by rotating the pinion of PF motor is described in figure 2-10. This motive power is conveyed to the Gear C through the Gear B. In the figure above, although the lever in order to drive Gear C, carriage lock, head cleaner mechanism is shown separately, it is constructed as one unit. Since the engagement of these two parts depends on the tension of the compression spring, if the lever is burdened, only Gear C and pump roller rotate and no more motive power is conveyed to the lever part.

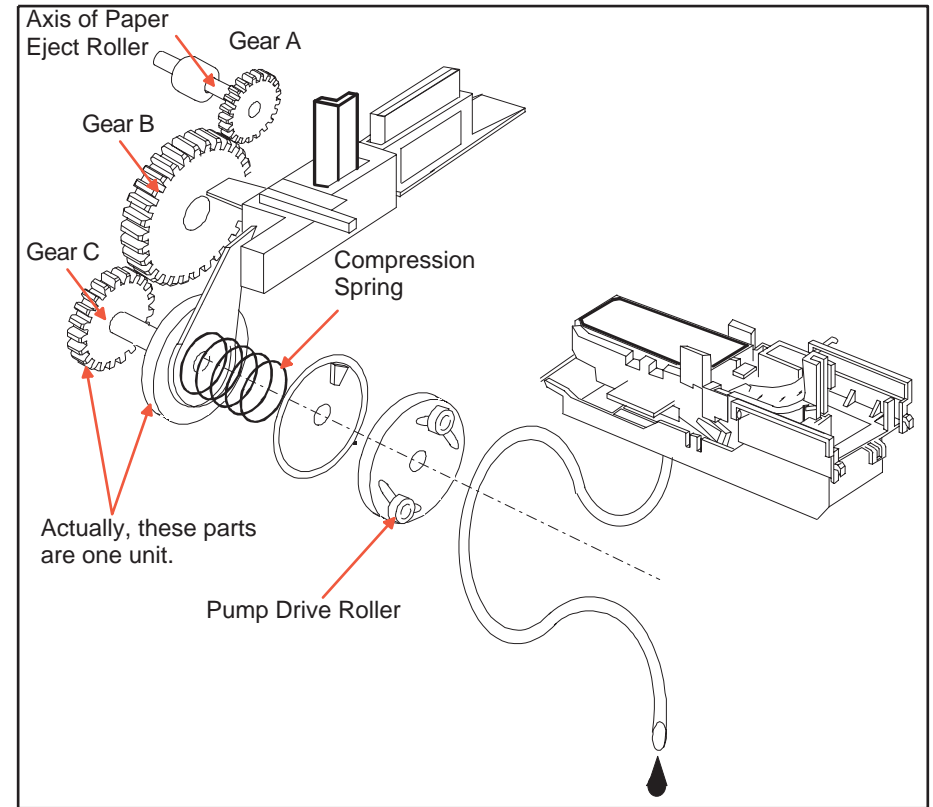

Figure 2-12. Pump Mechanism Power Transmission Process

The table below shows PF/Pump motor rotational direction and pump system operation.

**Table 2-7. Relationship between Pump Motor Rotation and it's Work**

PF/Pump motor rotational direction	Pump unit operation
Clockwise (CW) forward rotation	1)Release from the Pump pressure welding 2)Head cleaner reset 3)Carriage lock reset
Counterclockwise (CCW) backward rotation	1)Rotation towards pump pressure welding 2)Head cleaner set 3)Carriage lock set

Refer to Figure 1-13 in the right column which shows the pump operations at clockwise and counterclockwise rotation.

In the ink absorptive operation such as cleaning, flushing and initial ink charge except for printing operation, ink in the ink cartridge drains to the waste ink absorber(pad) through the cap by the pump unit drive. In case of printing and flashing drive, ink is popped out by the PZT in the print head, but in case of absorptive operation such as cleaning and initial ink charge, ink absorption is performed only by the pump drive without PZT drive after the head surface is adhered to the cap. The next page explains cap mechanism and relation between printer operation and cap.

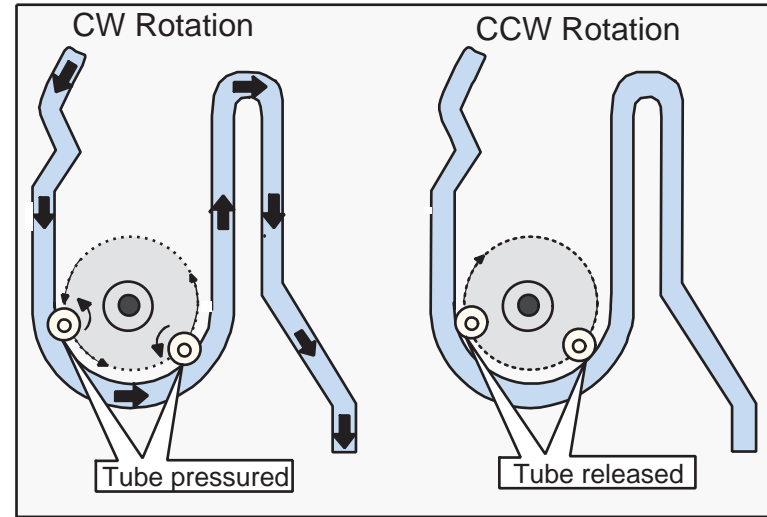

**Figure 2-13. Pump Roller Rotation and it's Operation**

### 2.1.1.6.1 Cap Mechanism

In the cap mechanism, in order to prevent ink from being thickened on the head surface, it is controlled that the head surface stays adherent to the rubber frame of the cap surface when the power is off. The absorber is spread in the cap and can hold a certain amount of ink which is absorbed from the head without draining it to the waste ink pad. Also, in the bottom of absorber, there are two valves in order to control adhesion of head and cap surface, and one exit to drain ink to the waste ink pad. If the carriage is out of HP (in this case, in the printable area or paper feed position), the valves on the cap mechanism stays in the position A in the figure above and are always closed. In this condition, the carriage collides with flag, actual ink absorption and slight ink absorption are performed. Also, by moving the carriage to further right side and colliding the flag for opening the valves with the frame, negative pressure is released in the state that head surface and cap are adhered. This makes it possible for ink on the nozzle plate surface to be ready for leaving from the cap in the stable condition.

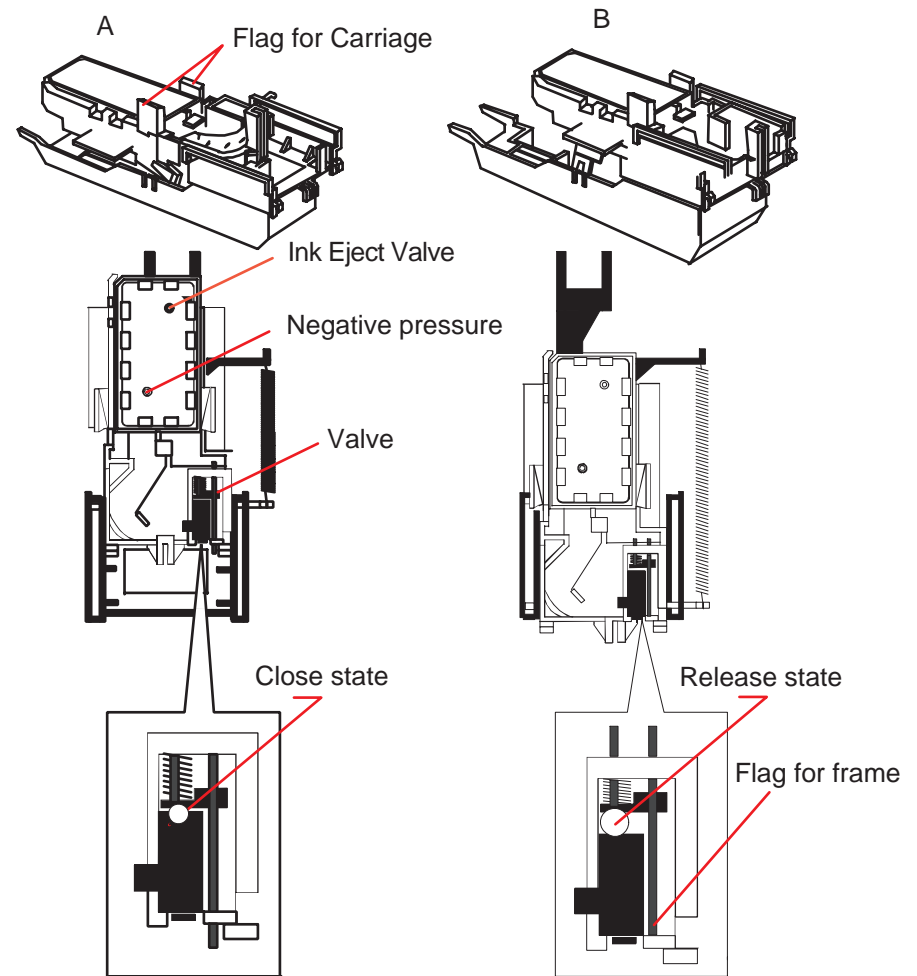

Figure 2-14. Cap Mechanism and Operation Principle

## 2.2 Electrical Circuit Operating Principles

Stylus Color 440/640/740 contains the following three electric circuit boards.

- Electronic Boards for Stylus Color 440 are;
  - Main: C206 Main-B, C255 Main Board
  - Power Supply: C206 PSB,PSE Board
  - Panel: C206 PNL Board
- Electronic Boards for Stylus Color 640 are;
  - Main: C256 Main, Main Board
  - Power Supply: C206 PSB,PSE Board
  - Panel: C206 PNL Board
- Electronic Boards for Stylus Color 740 are;
  - Main: C257 Main, Main Board
  - Power Supply: C257 PSB,PSE Board
  - Panel: C209 PNL Board

Refer to Figure 2-15 for the major connection of the 3 boards and their roles.

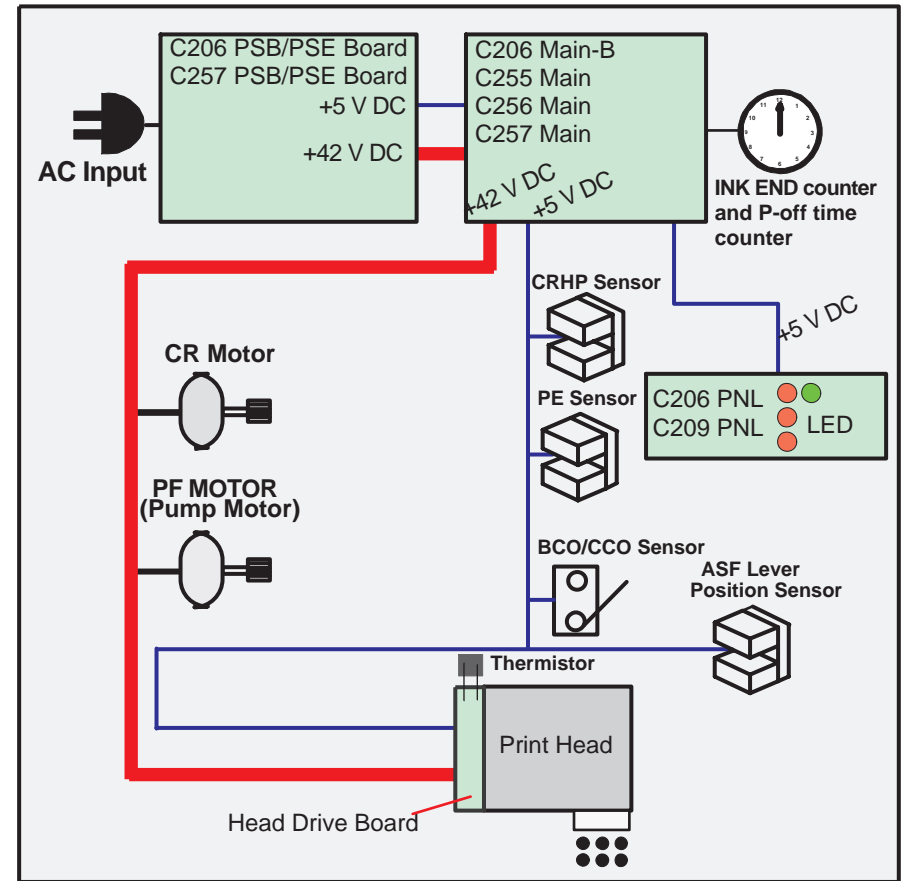

Figure 2-15. Electric Circuit of Stylus Color 440, 640, 740



### 2.2.1 C206 PSB/PSE and C257 PSB/PSE Power Supply Board (for Stylus Color 440, 640, 740)

There are 2 types of power supply boards for Stylus Color 440/640/740. The main components of the boards are the same, but the +5V regulator ICs which create steady +5V are different. These boards are power supply board with a RCC switching regulator, which generates +42VDC for drive part and +5VDC for logic part to drive the printer. One of the major characteristic of this board is that the same secondary switch is used as Stylus Color series printer. By using this switch, the following difference can be seen as superficial phenomena compared with products applied with primary switch method, such as Stylus Color IIs, II and Stylus 800/1000 series printer. The table below shows application of voltages generated by C206 PSB/PSE board.

1. Even if the switch is turned off during the middle of printer operation, since the driving power is turned off after the carriage goes back to the carriage lock position, the possibility of clogging ink nozzle will be decreased.
2. If the switch is turned off when the papers in the printer are still being carried except for the papers in the hopper, the same operation mentioned above is performed and the driving power is turned off after the paper is completely ejected.

**Table 2-8. Application of DC Voltage**

Voltage	Application
+42VDC	CR Motor PF/Pump Motor Head driving power supply
+5VDC	Power supply for logic control System control signal Sensor circuit power supply voltage LED panel drive power supply Nozzle selector control signal power supply voltage

Figure 2-16 shows block diagram of C206 PSB/PSE board. The process from the input of AC voltage to the output of 42 V DC and 5 V is explained in the following pages.

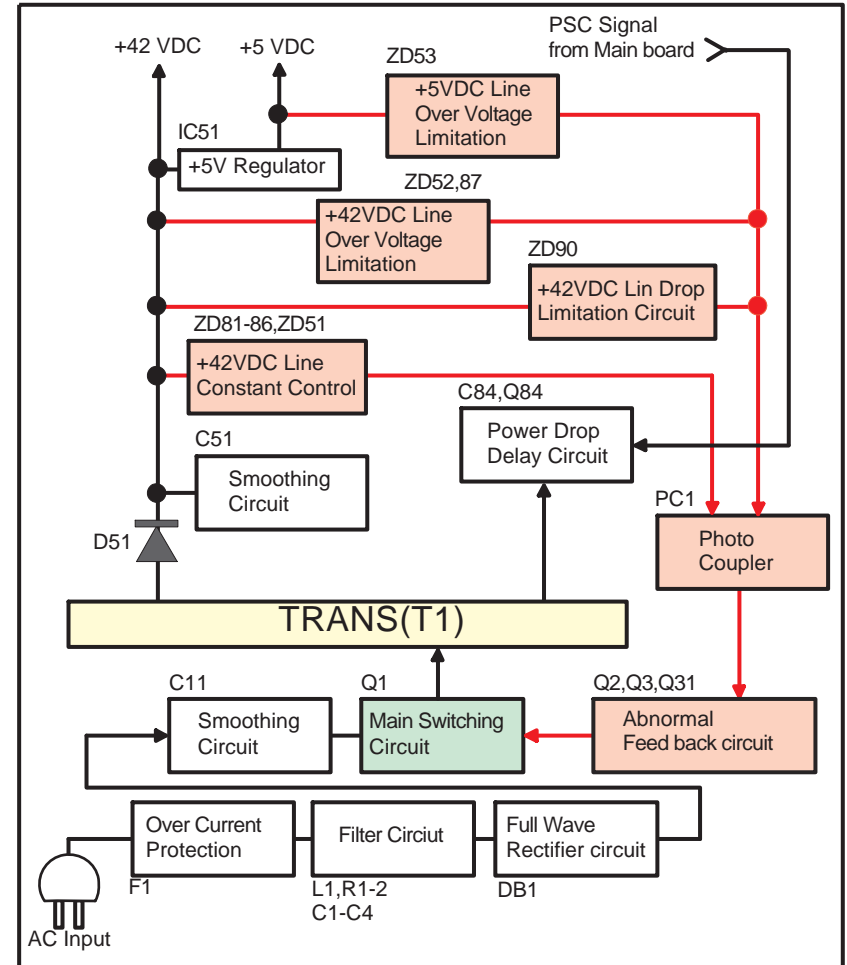

**Figure 2-16. C206/C257PSB, PSE Board Block Diagram**

- 1) Regardless of the state of power switch (On or OFF), the voltage is always applied in the primary side of the power supply board from the moment or at the state that AC-plug is plugged in. At this time, F1 plays a role of preventing AC100V from coming into the F1. L1 and R1-R2 also prevent high harmonic wave noise generated in the RC circuit filter which consist of C1~C4 and R1~R2 from going out, and eliminate the noise from outside here.
- 2) The AC is full-wave rectified by diode bridge DB1, and converted to  $\sqrt{2}$  x AC in voltage by smoothing electrolytic capacitor C11.
- 3) The pressured up direct current makes Q1 On through the starting resistor R31 and starts the primary side of the circuit.
- 4) When the primary side is On state, the energy(current) led by the electromagnetic induction through the trans (T1) does not flow to the secondary side since the diode(D51) on the secondary side is installed in the opposite direction.
- 5) When the energy which is charged in the trans is reaching the saturated state, the voltage which makes the Q1 On becomes weak gradually. At the point that this voltage drops at the certain voltage, C13 absorbs the current in the opposite direction and Q1 is quickly shut off by the resulting sharp drop.
- 6) When the primary side is turned off, the energy charged in the T1 is opened according to the diode(D51) direction which is installed on the secondary side. Basically, 42 V DC is output by these circuit operations and the number of T1 spiral coil.
- 7) +5VDC is generated by pressured down this +42VDC as power supply. IC51 pressures down the +42VDC and generates precise +5VDC by chopping off the output, forming the standard santooth wave form by the outer RC integration circuit.

The C206 PSB/PSE board has various control circuits to stop output if malfunction on the power supply board, on the main board or on the duty of printer mechanism happen. Following explains each control and protection circuits.

- +42V Line Constant Voltage Control Circuit:  
The output level of the +42V line is monitored by a detection circuit consisting of seven Zener diodes. This circuit prevents voltage from dropping for constant output voltage.
- +5V Line Over voltage Protection Circuit:  
This protection circuit is in the same line as +42V over voltage protection circuit is located. The output voltage level of the +5V line is monitored by a Zener diode. This circuit shuts down the circuit operation forcefully when the voltage level exceeds +9V.
- +42VDC Line Drop Limitation Circuit:  
This protection circuit is in the same line as +42V over voltage protection circuit is located. The output voltage level of the +42V line is monitored by a Zener diode. This circuit shuts down the circuit operation forcefully when the voltage level drops +36V.
- +42VDC Line Over voltage Circuit:  
This circuit is in the same line as +5V line over voltage protection circuit is located. The output level is monitored by two Zener diodes. If the voltage level exceeds +48VDC, this circuit stops circuit operation forcefully.
- +5V Line Constant Voltage/Constant Current Control Circuit:  
The output current is monitored by a +5VDC generation switching control IC(IC51), which also monitors the output voltage. This information is input to the internal comparator and stabilizes +5V line. Operation of the secondary side switch is explained in the following page.

- When the power is turned on, Q1 repeats ON/OFF automatically along with the increase and decrease of energy on the trans coil at the primary side. While the power is being on, PSC signal is input to the power supply board from the C206 Main-B/C255/C256/C257 Main board.
- This signal turns Q84 on and it becomes possible to discharge energy between 8-9 of T1. At this time, even if the power is turned off, the electrolytic capacitor keeps Q84 on for a while. By this electrolytic capacitor, output is hold at least 30 seconds even after the power is turned off. This time helps the printer to complete the P-Off operation.

### 2.2.2 C206 Main-B, C255 Main (for Stylus Color 440)

Various DC voltage generated on the C206 PSB/PSE board is added various signals in order to drive the printer function on the C206 main-B, C255 main, board the drive of CR/PF (Pump) motor and printing head is performed. Following figure shows the circuit diagram for Stylus Color 440.

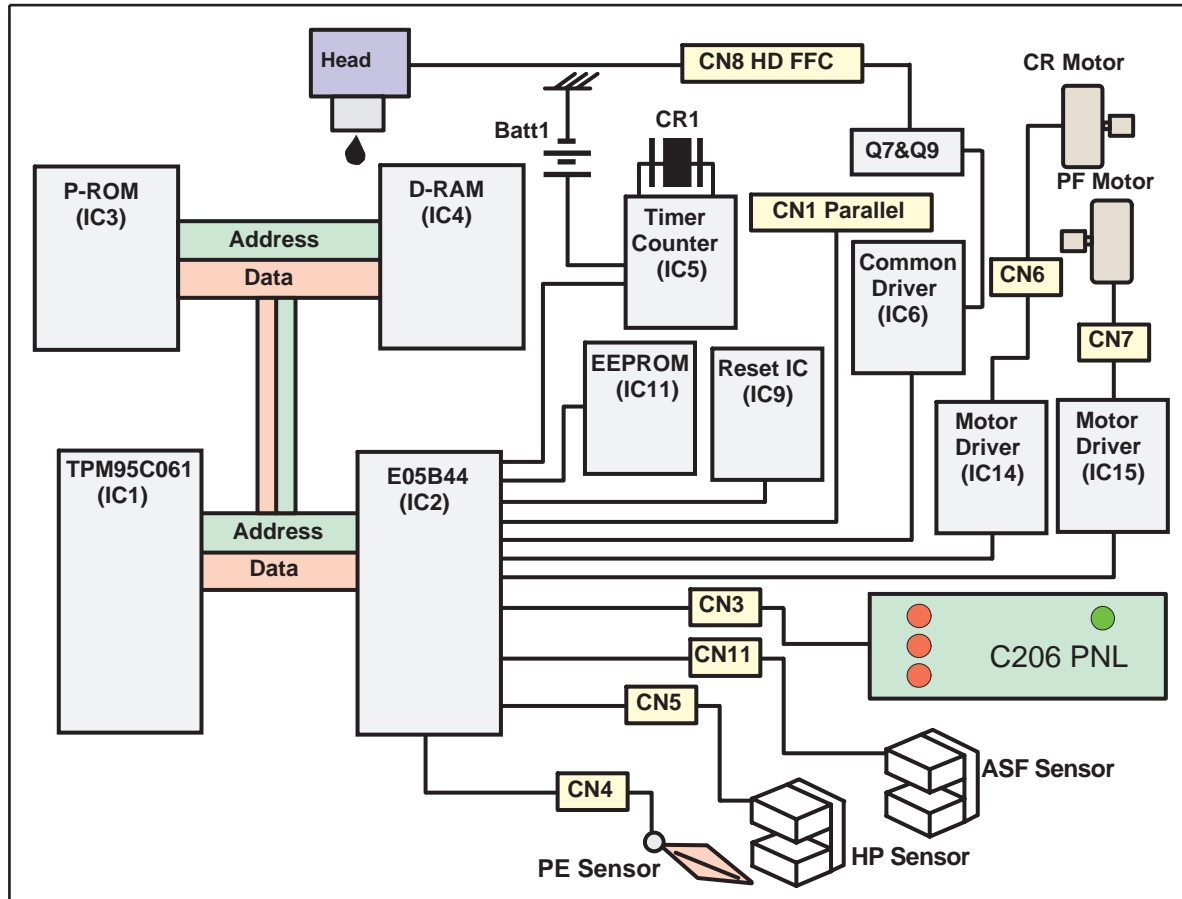

Figure 2-17.  
C206 Main-B, C255 Main Board Block for Stylus Color 440

**[CPU]**

The 16-bit CPU which is mounted on Stylus Color 440 is running at 25Mhz. Gate array manages most of controls and monitors. Likewise the Stylus Color, the D-RAM is applied for RAM which is used as work area for receiving data and developing the data and CPU manages its control such as CE, RAS/CAS controls.

**[Gate Array]**

E05B44 controls the following functions.

- Motor control  
Each motor performs data transmission that motives Micro-Step.
- Head voltage control  
In the ink jet printers, drive voltage wave form (trapezoidal wave form) in order to drive PZT is formed in the various shapes according to the types of the printers. Therefore, it is necessary to form appropriate drive form for each head. Head voltage control forms necessary wave form for each control signals and outputs them.
- EEPROM control  
The correction value to eliminate the error of each printers at production process is installed in the fixed address of IC. When the power is turned off, the contents set by users is written instantly, and is red to the RAM when the power is turned on.
- Sensor Data  
The sensor detects information at the various conditions, which is necessary for the printer operation. The gate array recognizes signals and changes over to the next control.
- Timer Data  
The timer IC that uses lithium battery as power source monitors how long the power is off. When the power is turned on, it is changed to appropriate cleaning level according to the time that the power is off.

- Parallel I/F control

With the use of IEEE1284 Nibble mode, it became possible not only to receive the data from the host but also to return various information which the printer possesses to the host.

**[Common Driver IC]**

The trapezoidal wave form circuit for the head drive is HIC, an improvement from the previous discrete structure. Because of this, it is not necessary to adjust the adjustable VR on the board during production process. Various electric charge/discharge control signals are all processed in the HIC.

**[CR/PF Motor Drive Circuit]**

Constant current drive is performed by the HIC. Out of this, only CR Motor is controlled for Micro-Step control and HIC becomes possible to flow the appropriate current value at each steps. (PF Motor has only 1-2, 2-2 phase drive method). Also, bipolar drive is performed on the 4 cables individually.

### 2.2.3 C256 Main (for Stylus Color 640)

Various DC voltage generated on the C206 PSB/PSE board is added various signals in order to drive the printer function on the C256 main board, and the drive of CR/PF (Pump) motor and printing head is performed. Following figure shows the circuit diagram for Stylus Color 640.

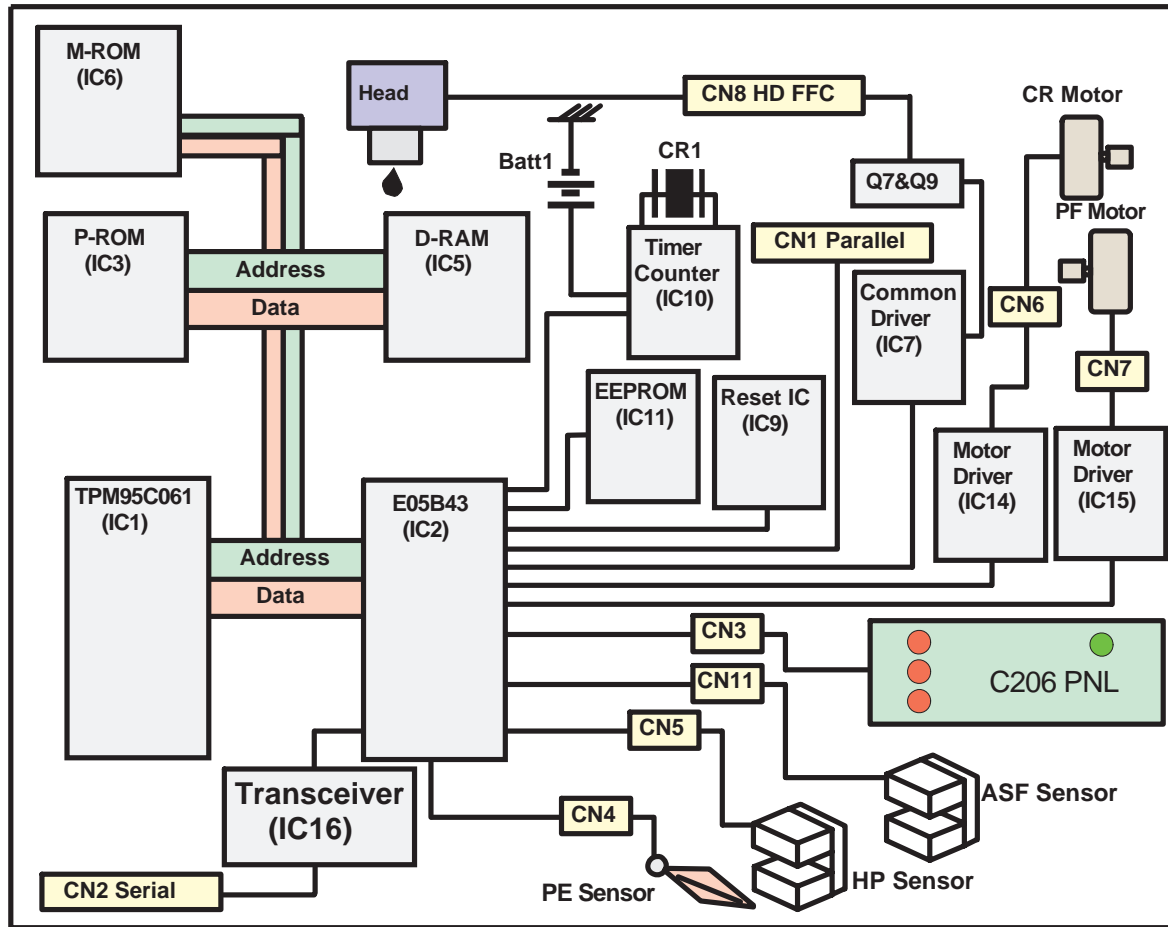

Figure 2-18. C256 Main Board Block for Stylus Color 640

**[CPU]**

The 16-bit CPU which is mounted on Stylus Color 640 is running at 25Mhz. Gate array manages most of controls and monitors. Likewise the Stylus Color, the D-RAM is applied for RAM which is used as work area for receiving data and developing the data and CPU manages its control such as CE, RAS/CAS controls.

**[Gate Array]**

E05B43 controls following functions.

- Motor control  
Each motor performs data transmission that motives Micro-Step.
- Head voltage control  
In the ink jet printers, drive voltage wave form (trapezoidal wave form) in order to drive PZT is formed in the various shapes according to the types of the printers. Therefore, it is necessary to form appropriate drive form for each head. Head voltage control forms necessary wave form for each control signals and outputs them.
- EEPROM control  
The correction value to eliminate the error of each printers at production process is installed in the fixed address of IC. When the power is turned off, the contents set by users is written instantly, and is red to the RAM when the power is turned on.
- Sensor Data  
The sensor detects information at the various conditions, which is necessary for the printer operation. The gate array recognizes signals and changes over to the next control.
- Timer Data  
The timer IC that uses lithium battery as power source monitors how long the power is off. When the power is turned on, it is changed to appropriate cleaning level according to the time that the power is off.

- Serial I/F Control  
The gate array receives serial data through the transceiver IC.
- Parallel I/F control  
With the use of IEEE1284 Nibble mode, it became possible not only to receive the data from the host but also to return various information which the printer possesses to the host.

**[Common Driver IC]**

The trapezoidal wave form circuit for head drive is became to HIC from the previous discrete structure. Because of this, it is not necessary to adjust the adjustable VR on the board during production process. Various electric charge/discharge control signals are all processed in the HIC.

**[CR/PF Motor Drive Circuit]**

Constant current drive is performed by the HIC. Out of this, only CR Motor is controlled for Micro-Step control and HIC becomes possible to flow the appropriate current value at each steps. (PF Motor has only 1-2, 2-2 phase drive method). Also, bipolar drive is performed on the 4 cables individually.

### 2.2.4 C257 Main, (for Stylus Color 740)

Various DC voltage generated on the C257 PSB/PSE board is added various signals in order to drive the printer function on the C257 main board the drive of CR/PF (Pump) motor and printing head is performed. Following figure shows the circuit diagram for Stylus Color 740.

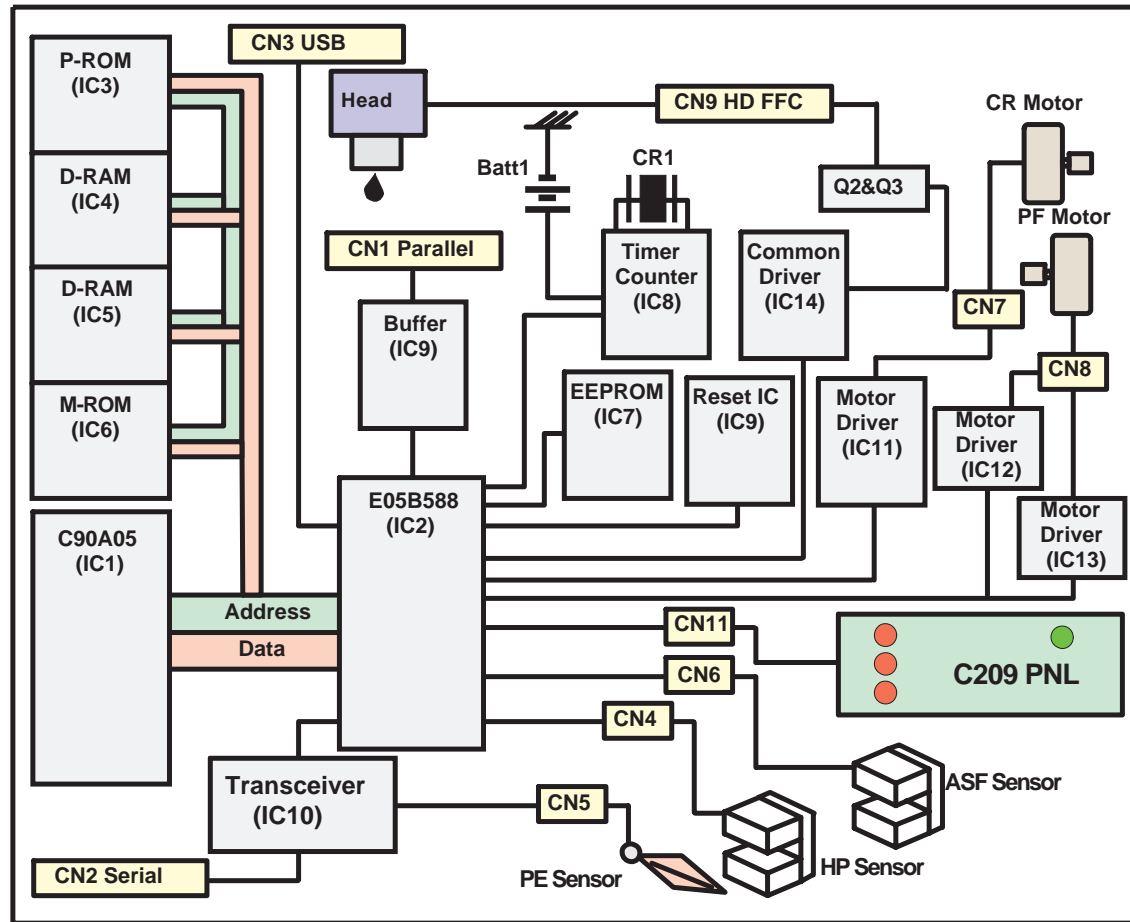

Figure 2-19. C257 Main Board Block for Stylus Color 740



**[CPU]**

The 16-bit CPU which is mounted on Stylus Color 740 is running at 24Mhz. Gate array manages most of controls and monitors. Likewise the Stylus Color, the D-RAM is applied for RAM which is used as work area for receiving data and developing the data and CPU manages its control such as CE, RAS/CAS controls.

**[Gate Array]**

E05B588 controls following functions.

- Motor control  
Each motor performs data transmission that motives Micro-Step.
- Head voltage control  
In the ink jet printers, drive voltage wave form (trapezoidal wave form) in order to drive PZT is formed in the various shapes according to the types of the printers. Therefore, it is necessary to form appropriate drive form for each head. Head voltage control forms necessary wave form for each control signals and outputs them.
- EEPROM control  
The correction value to eliminate the error of each printers at production process is installed in the fixed address of IC. When the power is turned off, the contents set by users is written instantly, and is red to the RAM when the power is turned on.
- Sensor Data  
The sensor detects information at the various conditions, which is necessary for the printer operation. The gate array recognizes signals and changes over to the next control.

- Timer Data  
The timer IC that uses lithium battery as power source monitors how long the power is off. When the power is turned on, it is changed to appropriate cleaning level according to the time that the power is off.
- Serial I/F Control  
The gate array receives serial data through the transceiver IC.
- Parallel I/F control  
With the use of IEEE1284 Nibble mode, it became possible not only to receive the data from the host but also to return various information which the printer possesses to the host.
- USB I/F Control  
The transceiver circuit which control the USB interface has been incorporated into this gate array.

**[Common Driver IC]**

The trapezoidal wave form circuit for head drive is became to HIC from the previous discrete structure. Because of this, it is not necessary to adjust the adjustable VR on the board during production process. Various electric charge/discharge control signals are all processed in the HIC.

**[CR/PF Motor Drive Circuit]**

Constant current drive is performed by the HIC. Out of this, only CR Motor is controlled for Micro-Step control and HIC becomes possible to flow the appropriate current value at each steps. (PF Motor has only 1-2, 2-2 phase drive method). Also, bipolar drive is performed on the 4 cables individually.

### 2.2.4.1 Reset Circuits

#### [C206 Main-B, C255 Main for Stylus Color 440]

The reset circuit prevents the CPU from running away, which is caused by the unstable voltage in the logic line during the power ON/OFF operation. And reset IC(IC9) monitors level of power voltage at the over loading or malfunction on the circuit and manages the printer to operate normally, keeping the damage to the printer minimum during the abnormal situations. On the C206 main-B and C255 main board.

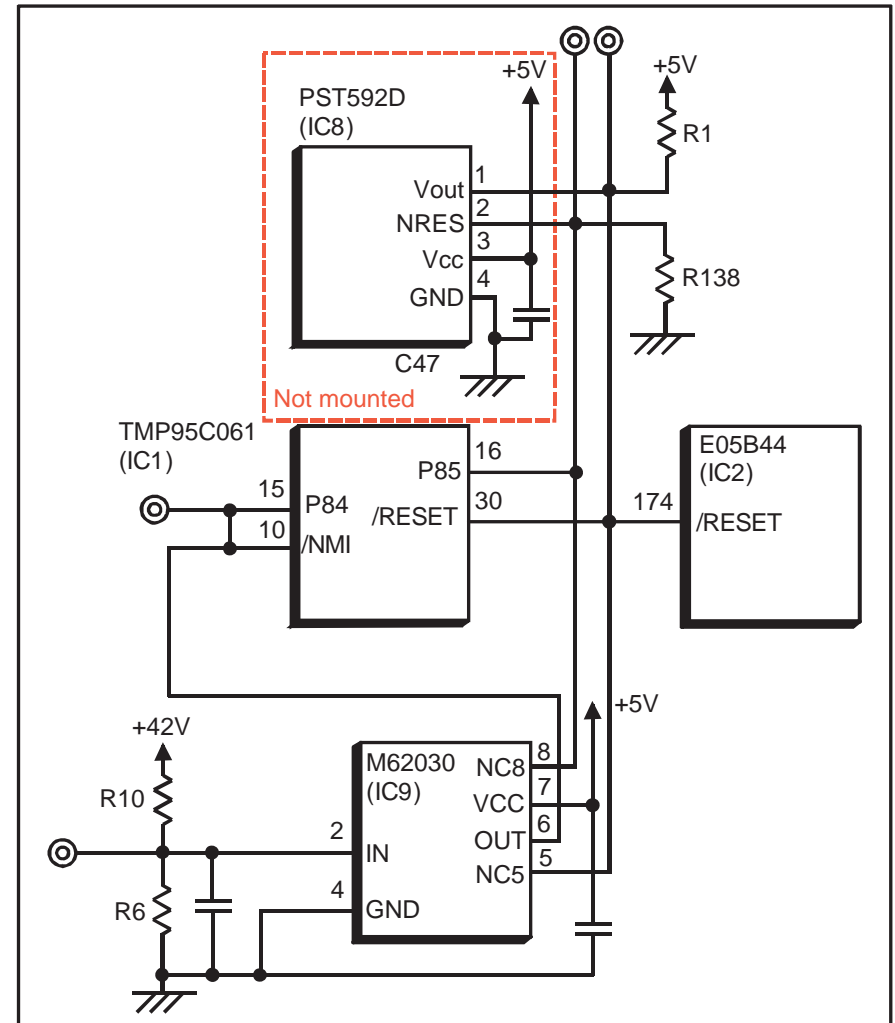
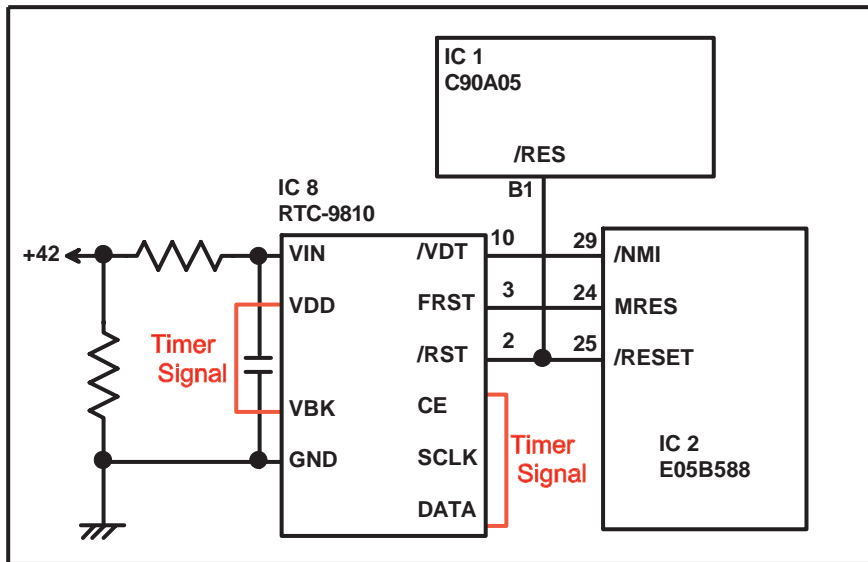

Figure 2-20. Reset Circuit for Stylus Color 440



**[C257 Main for Stylus Color 640]**

The reset circuit prevents the CPU from running away, which is caused by the unstable voltage in the logic line during the power ON/OFF operation. And reset IC(IC8) monitors level of power voltage at the over loading or malfunction on the circuit and manages the printer to operate normally, keeping the damage to the printer minimum during the abnormal situations. On the C257 main board. The IC 8 has 2 functions both the timer counter and creating a reset signal.



**Figure 2-22. Reset Circuit for Stylus Color 740**

**2.2.4.2 Sensor Circuits**

The following sensor circuits are mounted in the Stylus Color 440/640/740 and selects appropriate operations based on the returned status.

- ASF Sensor (Photo):  
An ASF sensor detects the position of return lever when the power is turned on, and causes the paper to be picked up by the pick up roller from the normal initial condition. (Refer to section 2.1.1.3 for detail.)
- PE Sensor (Photo):  
A PE sensor determines if there is paper in the printer. Based on the signal form this sensor, a particular paper edge treatment such as Micro-weave printing is performed.
- HP Sensor (Photo):  
A HP sensor detects the carriage home position. It is used for managing printing position and cleaning, etc.
- Thermistor Sensor  
A thermistor sensor keeps stable printing quality, changing PZT drive voltage(VH) slightly according to changes of environmental temperature.
- Cartridge Sensors:  
Cartridge sensors are built into the Bk, CMY cartridge on the carriage unit respectively to determine if the cartridge is installed or not when it is exchanged or the power is turned on. In case of Stylus Color 440/640/740, the counter is reset at every time the cartridge is removed.

The following three figures show the sensor circuits. Out of the data such as EPW with IEEE 1284 Nibble mode to be returned to the host, the data to indicate ink consumption is calculated and managed by the counter of the firmware. Therefore, it is omitted here.

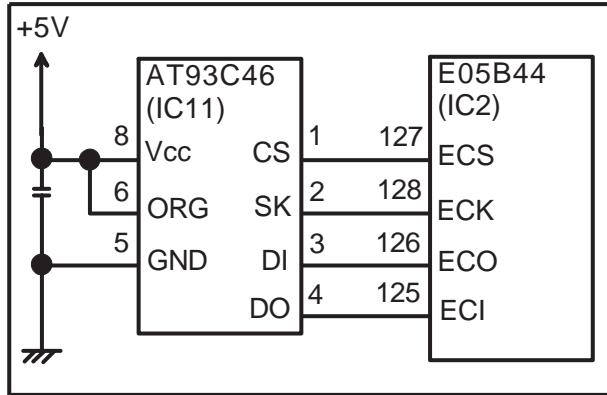

Figure 2-23. Figure 5-23. Sensor Circuit for Stylus Color 440

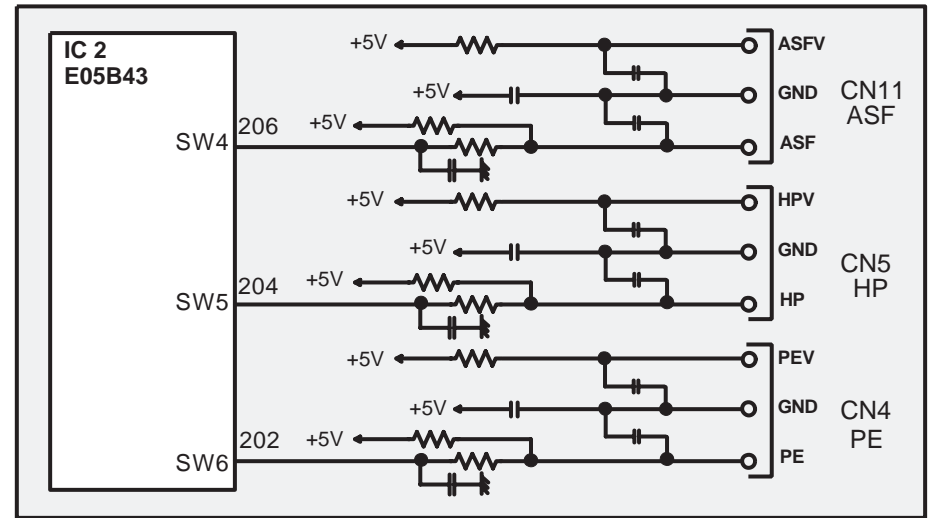

Figure 2-24. Figure 5-24. Sensor Circuit for Stylus Color 640

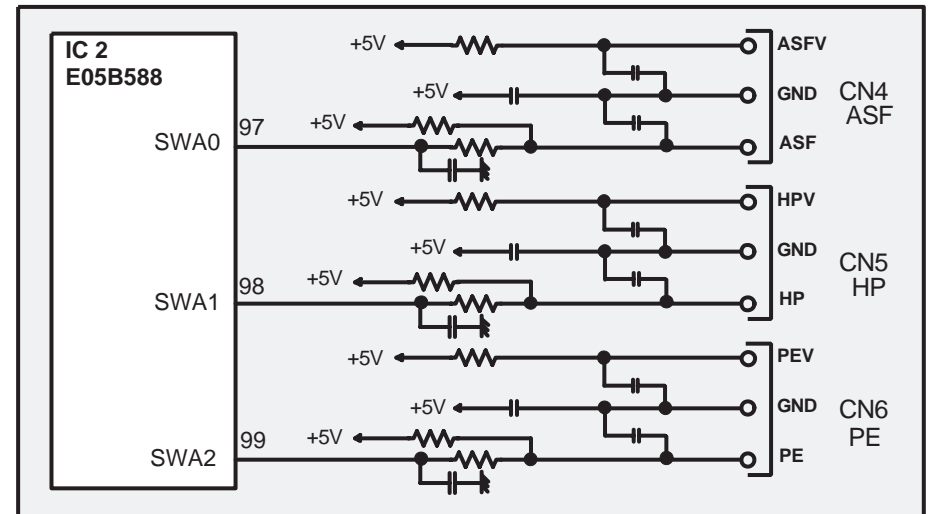

Figure 2-25. Sensor Circuit for Stylus Color 740

### 2.2.4.3 EEPROM Control Circuits

The EEPROM of Stylus Color 440/640/740 has following contents. Gate array controls operations of reading data when the power is on and writing data when the power is off.

- Ink consumption (Bk, CMY)
- CL counter (Various cleaning operations that are previously done are memorized)
- Destination information
- Information of various adjustment values (Bi-D, VH voltage, etc.)
- CPSI pass word
- Other various setting values by the user

EEPROM is connected to the Gate array by 4 lines and performs following functions. The figure below shows EEPROM control circuit.

- CS: Chip selection signal
- CK: Data synchronism clock pulse
- DI: Data writing line (serial data) at power off.
- DO: Data reading line (serial data) at power on.

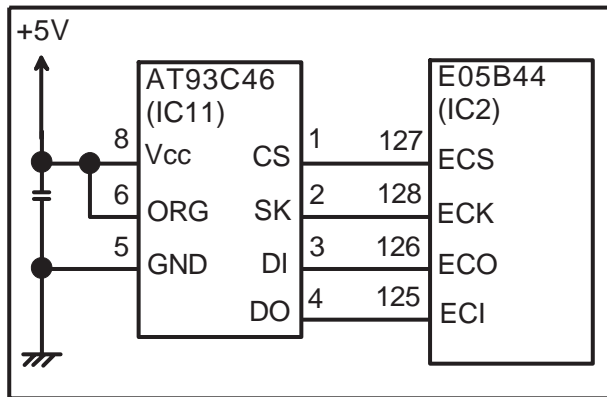

Figure 2-26. EEPROM Control Circuit for Stylus Color 440

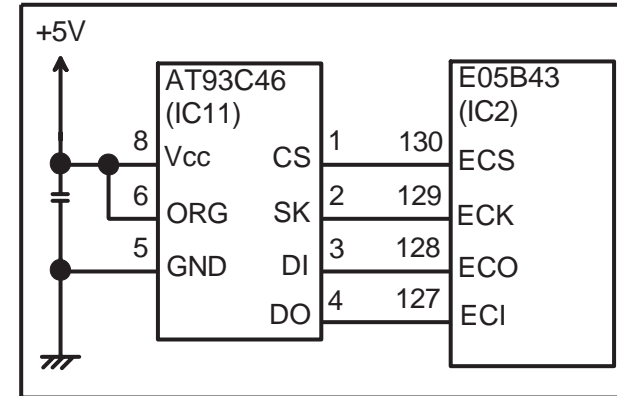

Figure 2-27. EEPROM Control Circuit Stylus Color 640

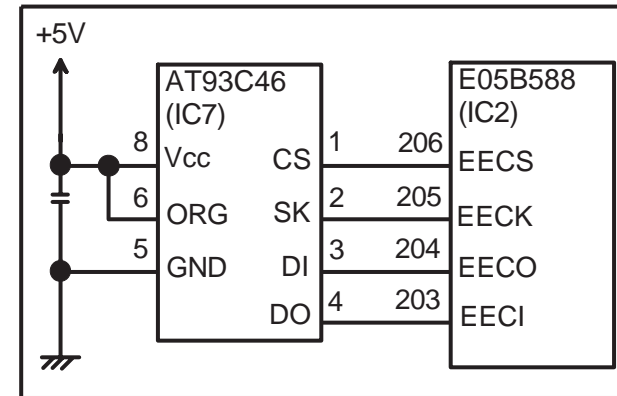

Figure 2-28. EEPROM Control Circuit for Stylus Color 740

### 2.2.4.4 Timer Circuit

A lithium battery is mounted on the main board and calculates how long the printer is not used. The timer IC starts counting with oscillation motivated by the crystal oscillator using this battery as a power source. The following figures show connection of the Timer circuit. The followings explain about operation of this circuit.

- When the printer is on, power is supplied to the Timer IC by applying +5V quickly through the D1.
- This power is also used for the power to oscillator. The oscillation wave form is input to XI terminal.
- Since the oscillation wave form of CR1 is analog wave form, it is processed into the pulse form in the Timer IC.
- When the printer is turned on, the Timer IC outputs power off time as serial data to the gate array.
- Once the printer is turned off, 3VDC of BAT1(lithium battery) is supplied as power source for the Timer IC through D7.
- Since +5V at the power on is higher than +3V of the lithium battery, the power is not being consumed from the lithium battery.

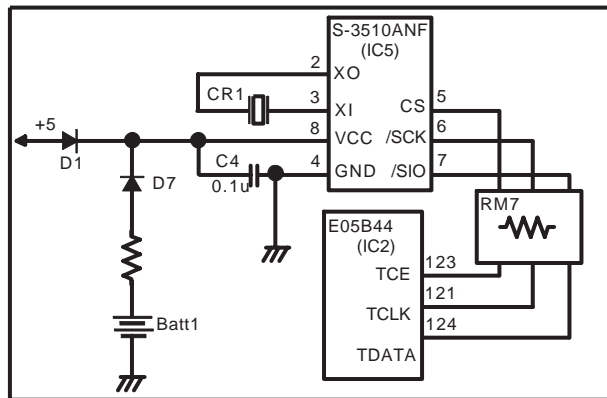

Figure 2-29. Timer Control Circuit for Stylus Color 440

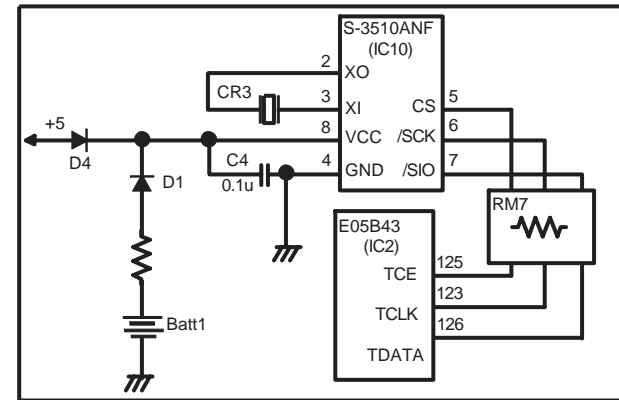

Figure 2-30. Timer Counter Circuit for Stylus Color 640

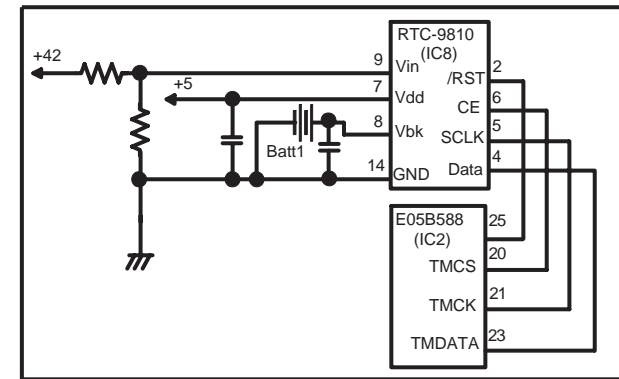

Figure 2-31. Timer Counter Circuit for Stylus Color 740

### 2.2.4.5 DRAM Control

In the Dynamic RAM control, output and formation of CAS and RAS control signals become necessary in addition to the output of CS signal. The CPU not only controls that but also perform the output of CS signal of P-ROM. Refresh timing is performed in the CAS Before RAS.

### 2.2.4.6 Print Head Control Circuit

The print head control circuit of Stylus Color 440/640/740 has following characteristics.

- Common wave form circuit became one HIC.
- Slight vibration mode is added.(when the CR motor is accelerating)
- High speed drive 14.4Khz (trapezoidal wave form)
- Big Nozzle configuration (resolution in the vertical direction)90dpi  
(However, black nozzle is 2 lines structure)

Also, Stylus Color 440/640/740 does not have Micro-dot control as dot shooting control, but there are two types; Normal-dot and Normal dot-2dot.Normal-dot-2dot was called Dual Firing in the Stylus Color IIs/820. These setting/change are controlled automatically by setting of the printer driver that is determined by the user. The followings are required conditions to perform the normal-dot 2-dot.

- At the OHP, Normal sheet setting (360X360 dpi)
- At the ordinary paper and resolution 360X360 dpi setting

The control circuit is considered as 2 divided parts; 1) trapezoidal wave form generation circuit (common drive circuit) to drive PZT in the head, and 2) Nozzle-selector drive circuit to determine which nozzle should be used. The Nozzle-Selector is attached to the head unit just like the previous models. The common drive circuit is hybridized as one HIC and mounted on the main control board.

See the following pages for the head drive circuit block diagrams for each printer.



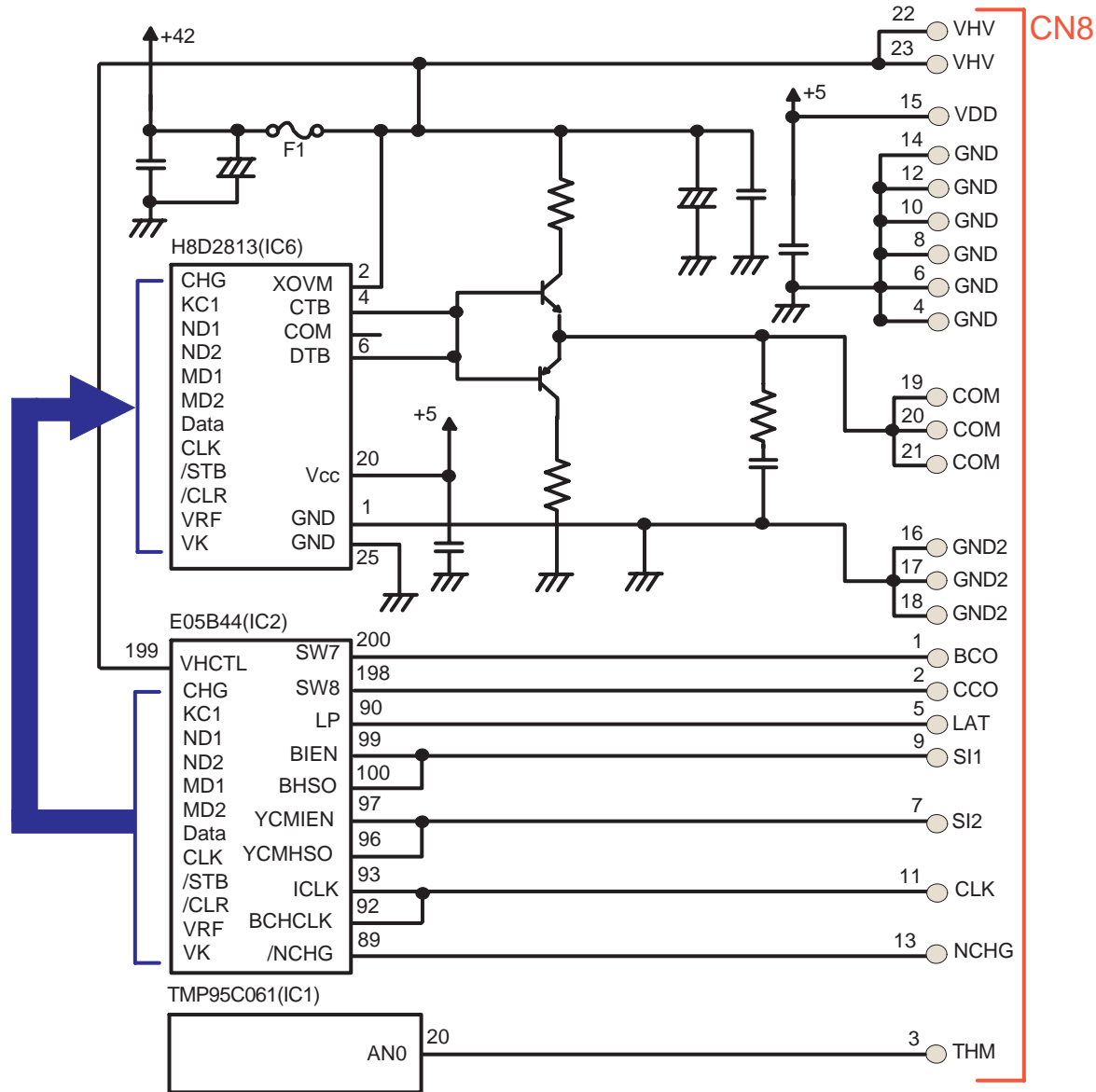

Figure 2-32. Head Drive Circuit for Stylus Color 440

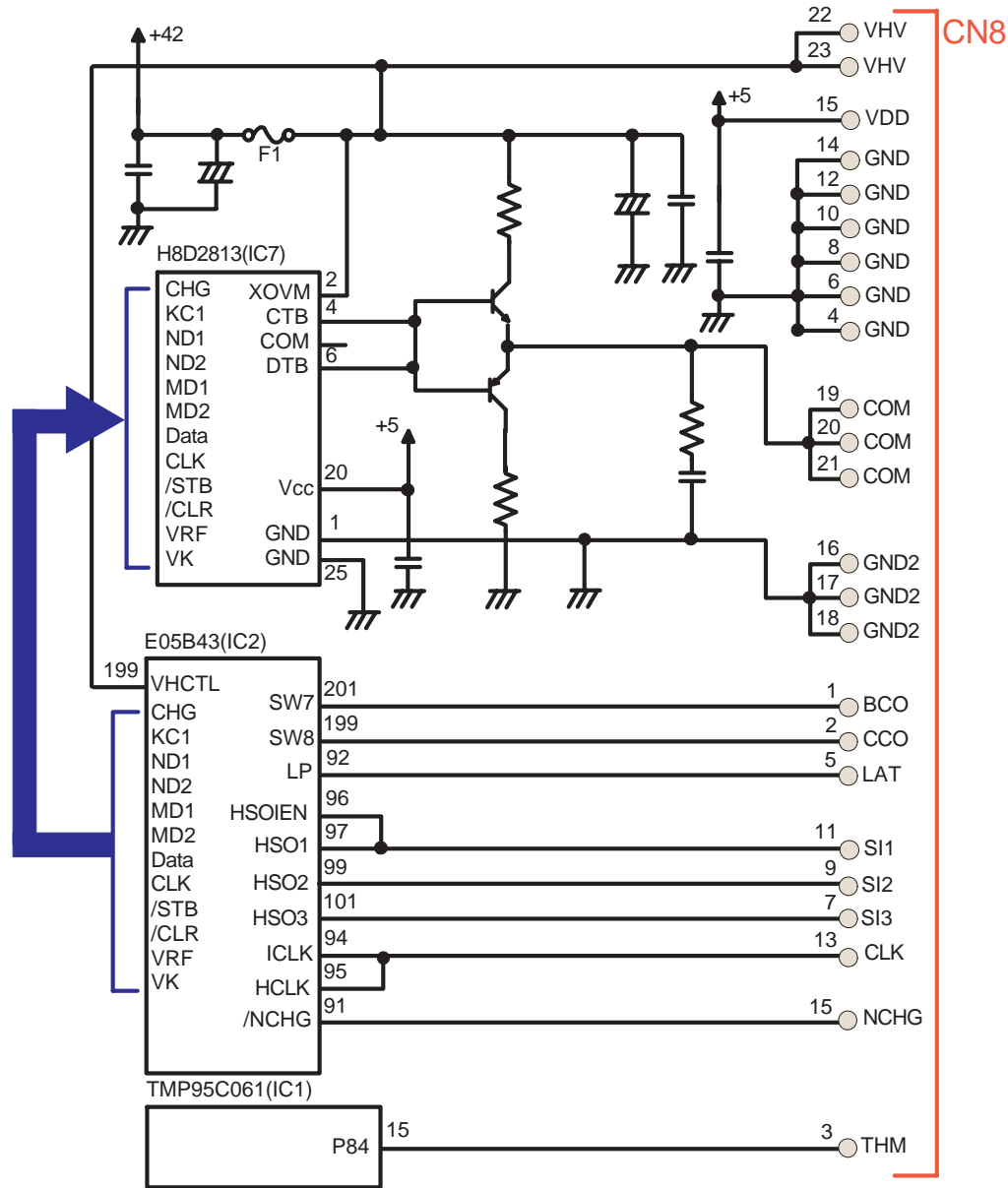

Figure 2-33. Head Driver Circuit for Stylus Color 640

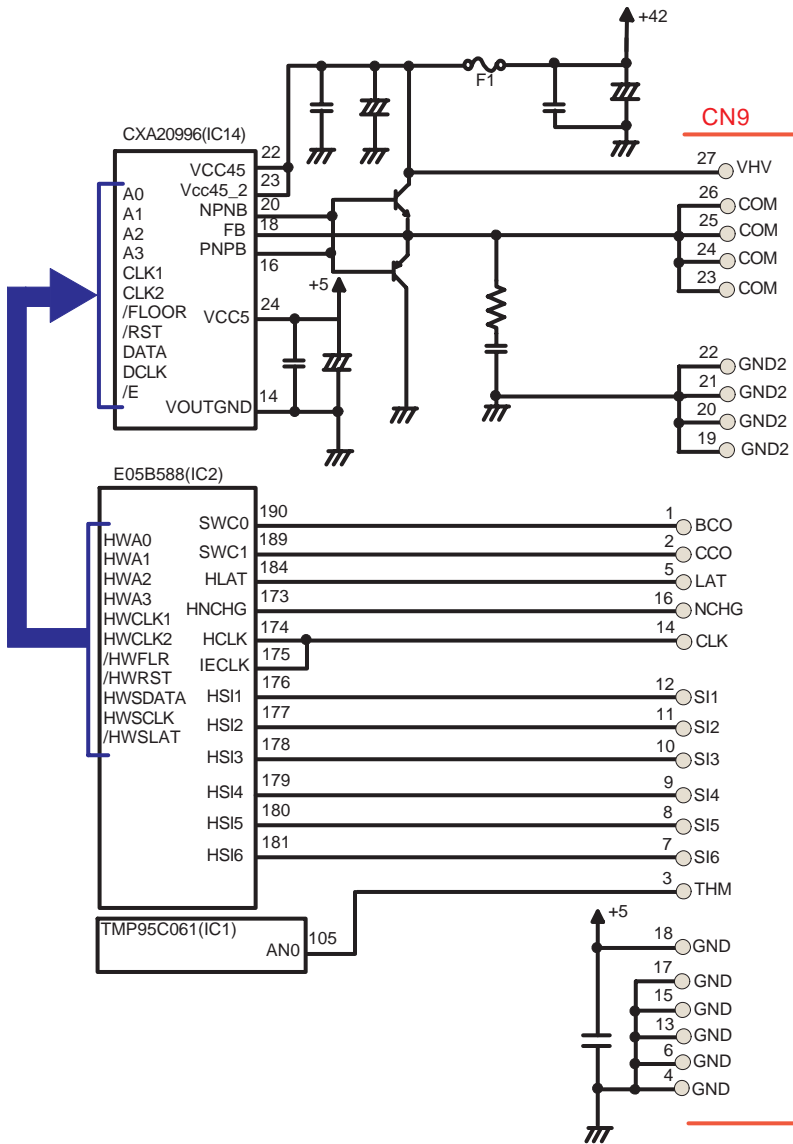

Figure 2-34. Head Drive Circuit for Stylus Color 740

**[Common drive circuit]**

The shape of trapezoidal wave form will be different according to the printing operation, slight vibrations at the non-printing nozzle and waiting condition. However, the IC6(for Stylus Color 440), IC7(for Stylus Color 640), IC14(for Stylus Color 740) generates all wave forms as drive wave forms by resistance(electric) welding control of common voltage drive control signal that is output from the IC2(gate array) in the figure above.

**Table 2-9.**

**Specifications of H8D2813/CXA20995 for Stylus Color 440, 640, 740**

Items	Contents
Drive Power Voltage	42 ± 5% Starts supplying after 5V rises and be stabilized./ Stops supplying before +5V drops.
Final Drive Element	2SC3746(for charging), 2SA1469(for discharging)
Operation at the Reset	Off on the both charging and discharging sides. Supplies drive power source.

This common voltage trapezoidal wave form can be observed anytime after the +5V rises even if there is printing data or not. (Q7:3-pin,Q9:3-pin for Stylus Color 440 and Q2: 3-pin, Q3: 3-pin for Stylus Color 640, 740)

**[Nozzle Selector Drive Circuit]**

In order to motivate the print head to carry out printing, it is necessary to transmit the printing data to the appropriate nozzles, which becomes direct signals to drive PZT. This data transmission is performed by the serial method, however the data output for each black and CMY head is transmitted by the parallel method.

### 2.2.4.7 PF (Pump) Motor Drive Circuit

IC15(LB1845) on C206 Main-B, C255 Main board, IC15(UDN2917) on C256 Main board, and IC12/13(A3956) on C257 Main board are used for driving PF (Pump) motor. In the IC, Bi-polar drive PWM current control type is performed, making it possible to provide stable current to each phase of motor. Also, it makes possible to change over the reference voltage as drive current settings by making few combinations using current setting ports(input). However, firmware does not support Micro-step in the Stylus Color 440/640/740. The figures below show connection diagram of PF (Pump) motor drive circuit.

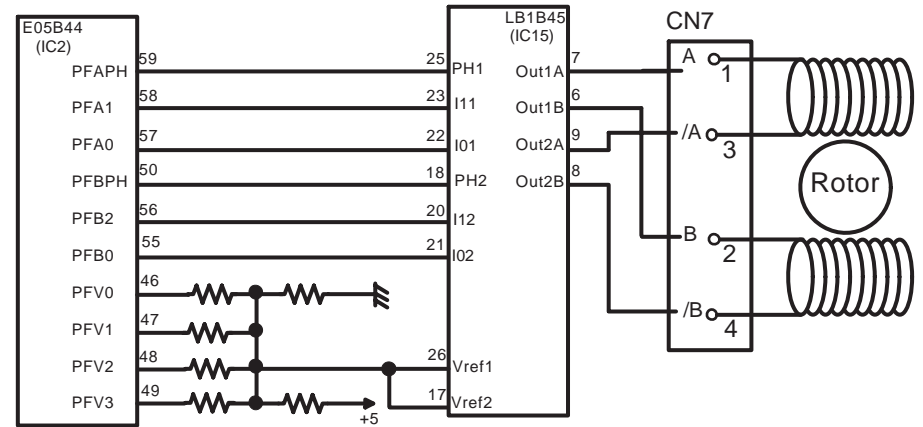

Figure 2-35. PF (Pump) Motor Drive Circuit for Stylus Color 440

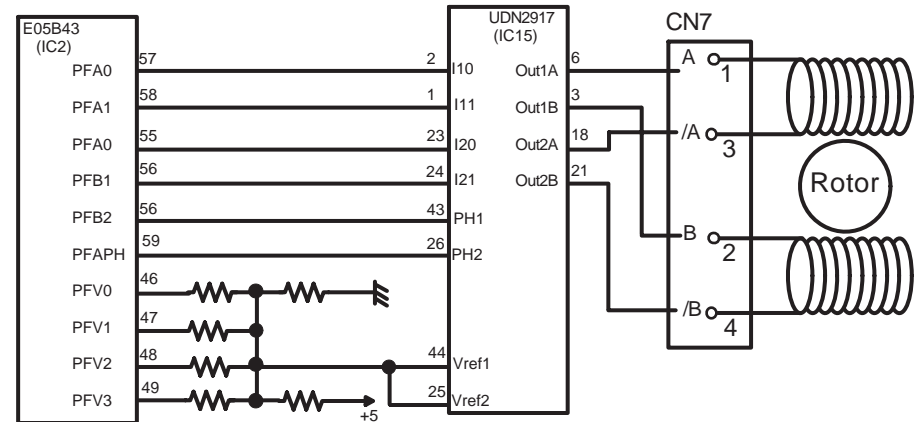

Figure 2-36. PF (Pump) Motor Drive Circuit for Stylus Color 640

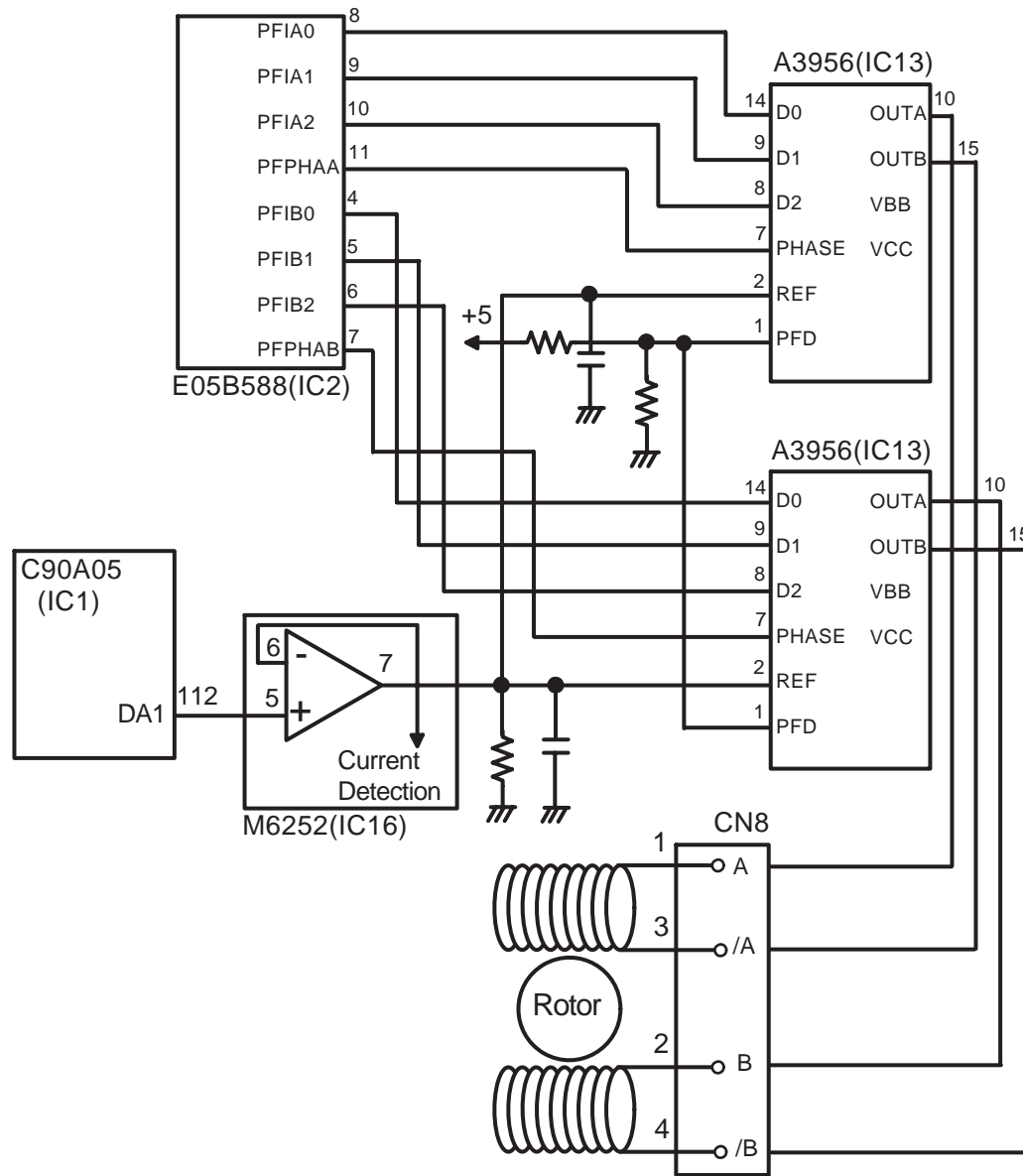

Figure 2-37. PF (Pump) Motor Drive Circuit for Stylus Color 740

2.2.4.8 CR Motor Drive Circuit

IC14(LB1845) on C206 Main-B, C255 Main board, IC14(UDN2917) on C256 Main board, and IC11(LB1847) on C257 Main board are used for driving CR motor. In the IC, Bi-polar drive PWM current control type is performed, making it possible to provide stable current to each phase of motor. The figures below show carriage motor drive circuit.

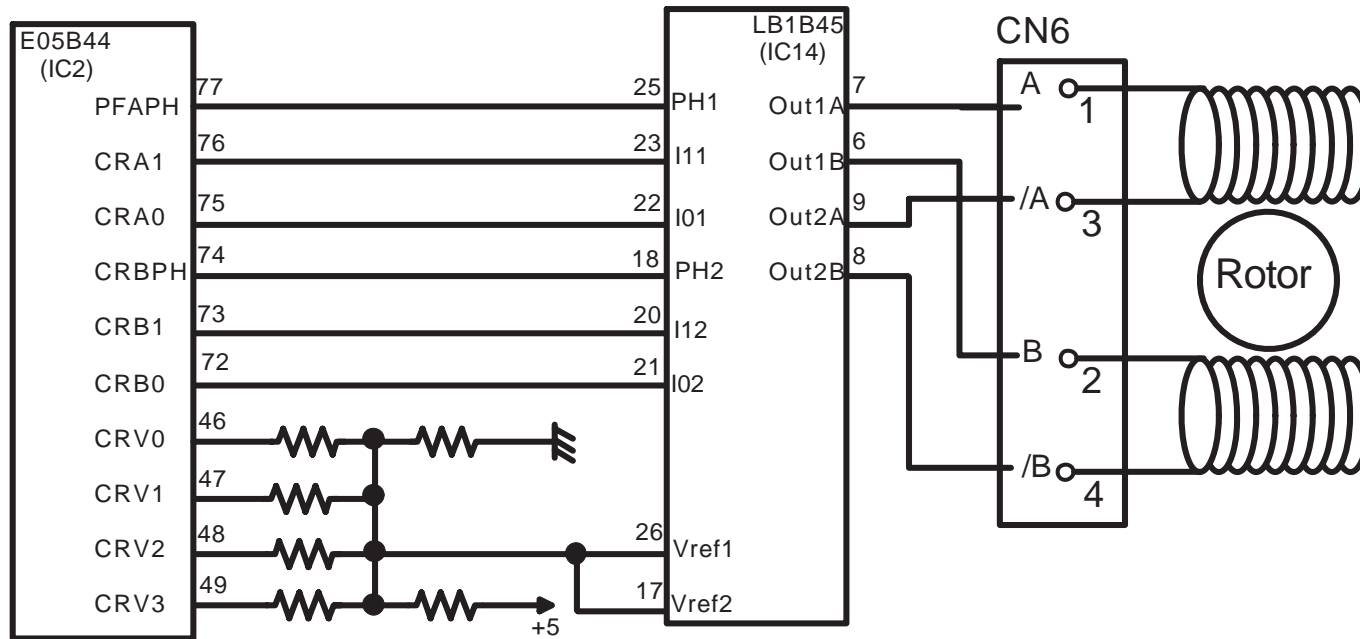

Figure 2-38. Carriage Motor Drive Circuit for Stylus Color 440

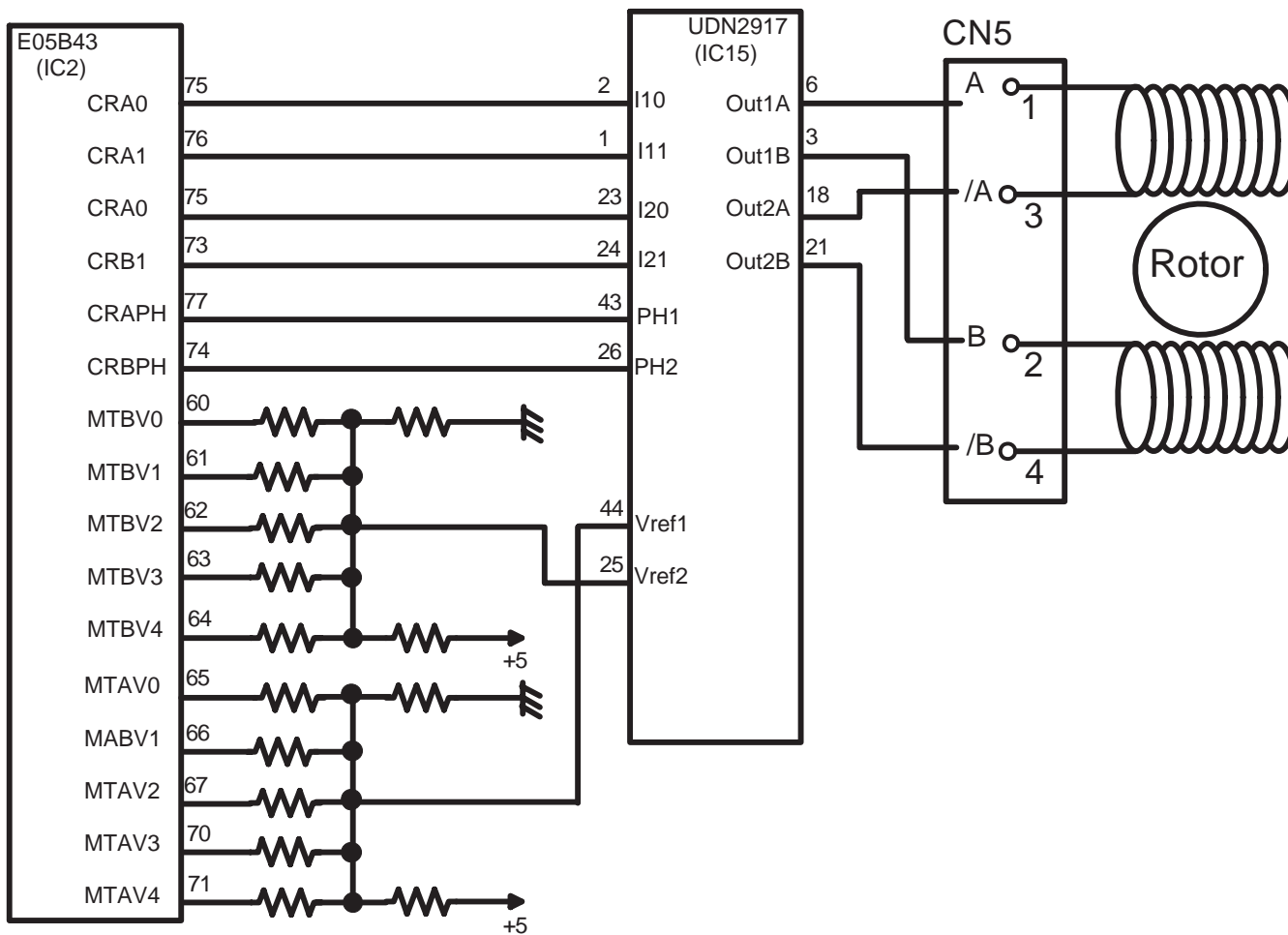

Figure 2-39. Carriage Motor Drive Circuit for Stylus Color 640

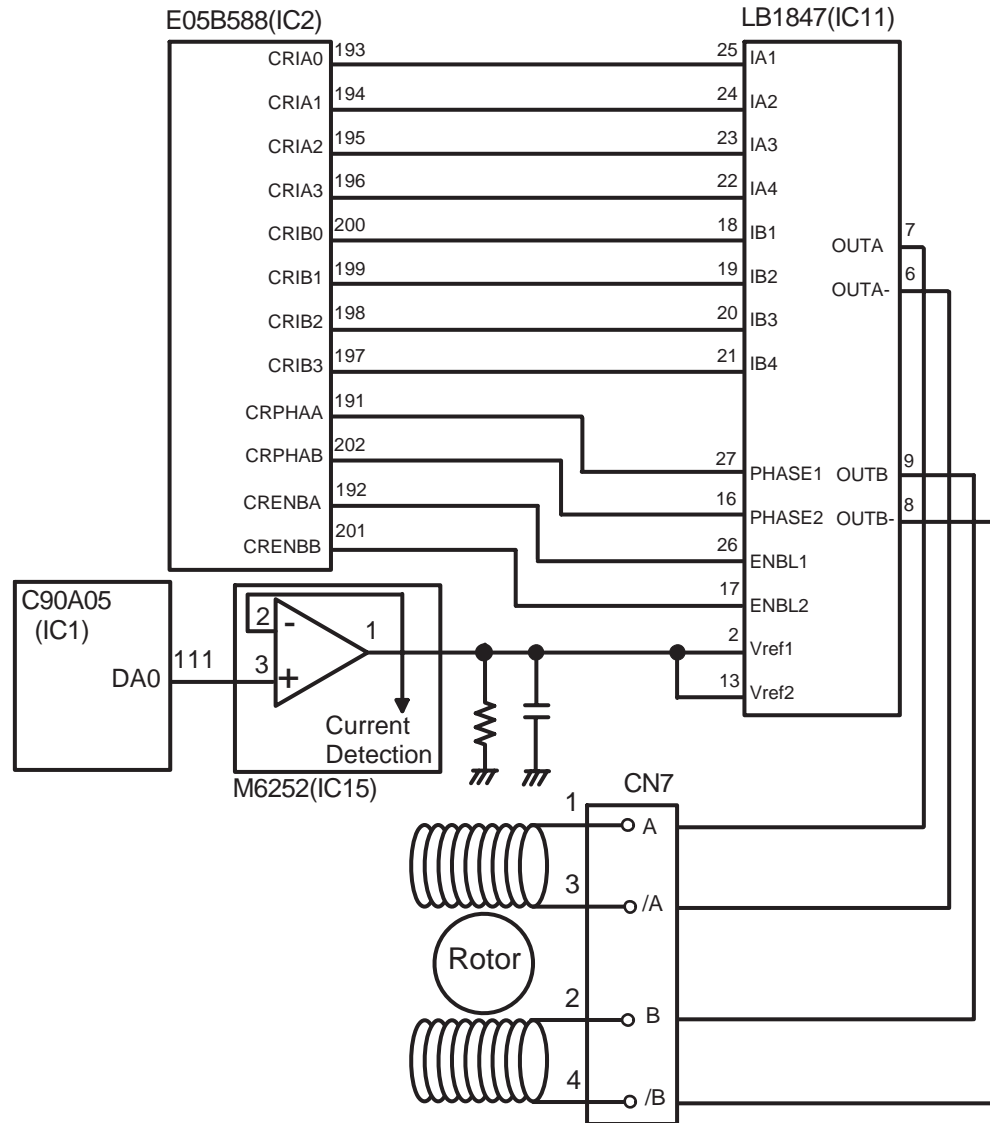

Figure 2-40. Carriage Motor Drive Circuit for Stylus Color 740



**CHAPTER**

**3**

# **TROUBLESHOOTING**

### 3.1 Troubleshooting

The printer may exhibit different symptoms for the same problem, which makes troubleshooting more difficult. This section, however, provides simple and effective ways to facilitate troubleshooting.

The following flowchart illustrates the main steps of the trouble shooting process.

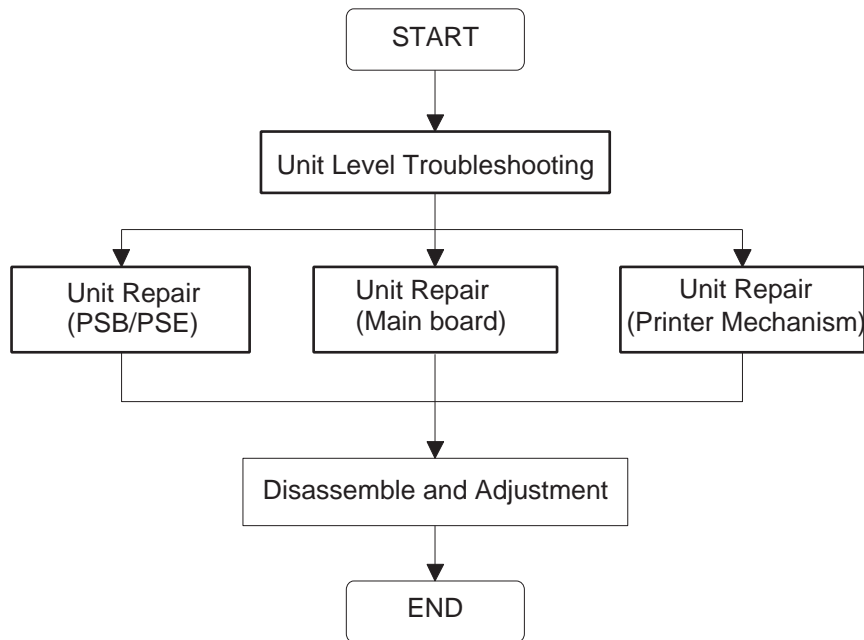

Figure 3-1. Troubleshooting Process Flowchart

Table 3-1. Motor Resistance and Measurement Procedure

Motor Name	Location	Check Point	Resistance
CR Motor	<ul style="list-style-type: none"> <li>Stylus Color 440/640 CN6 (Main board *)</li> <li>Stylus Color 740 CN7 (Main board *)</li> </ul>	Pins 1 & 3, Pins 2 & 4	7.8 Ohms ± 10%
PF (Pump) Motor	<ul style="list-style-type: none"> <li>Stylus Color 440/640 CN7 (Main board *)</li> <li>Stylus Color 740 CN8 (Main board *)</li> </ul>	Pins 1 & 3, Pins 2 & 4	7.8 Ohms ± 10%

\* Main board refers to the following:  
 Stylus Color 440: C206Main-B, C255Main  
 Stylus Color 640: C256Main  
 Stylus Color 740: C257Main

See the following page for Table 3-2, “Sensor Check” and Table 3-3, “Printer Condition and Panel Status”.

Table 3-2. Sensor Check

Sensor Name	Location	Signal Level	Sensor Status
Paper End Sensor	<ul style="list-style-type: none"> <li>Stylus Color 440/640 CN4/Pins 1 &amp; 2</li> <li>Stylus Color 740 CN5/Pins 1 &amp; 2</li> </ul>	Open: less than 0.7 V	Paper loaded
		Close: more than 2.4 V	No paper
Carriage Home Position Sensor	<ul style="list-style-type: none"> <li>Stylus Color 440/640 CN5/Pins 1 &amp; 2</li> <li>Stylus Color 740 CN4/ Pins 1 &amp; 2</li> </ul>	Open: less than 0.7 V	Home position
		Close: more than 2.4 V	Out of home position
ASF Phase Sensor	<ul style="list-style-type: none"> <li>Stylus Color 440/640 CN11/Pins 1 &amp; 2</li> <li>Stylus Color 740 CN6/ Pins 1 &amp; 2</li> </ul>	Open: less than 0.7 V	Home position
		Close: more than 2.4 V	Out of home position
Black Cartridge Sensor	<ul style="list-style-type: none"> <li>Stylus Color 440/640 CN8/ Pins 1 &amp; 18</li> <li>Stylus Color 740 CN9/Pins 1 &amp; 19</li> </ul>	On: 0V	Black cartridge out
		Off: more than 2.4 V	Black cartridge installed
Color Cartridge Sensor	<ul style="list-style-type: none"> <li>Stylus Color 440/640 CN8/ Pins 2 &amp; 18</li> <li>Stylus Color 740 CN9/Pins 2 &amp; 19</li> </ul>	On: 0V	Color cartridge out
		Off: more than 2.4 V	Color cartridge installed
Thermistor	<ul style="list-style-type: none"> <li>Stylus Color 440/640 CN8/ Pins 3 &amp; 18</li> <li>Stylus Color 740 CN9/ Pins 2 &amp; 19</li> </ul>	Analog data	Change the VH voltage of charge pulse for common driver circuit

Table 3-3. Printer Condition and Panel Status

Error Status	Indicators				Recovery
	Power	Ink out (Black)	Ink Out (Color)	Paper Out	
Paper Out	---	---	---	On	Load paper by pressing the load/eject button.
Paper jam condition	---	Off	Off	Blink	Eliminate a paper then press the load/eject button.
No Ink cartridge or Ink end (black)	---	On	---	---	Install a new black ink cartridge by pressing the load/eject button for 3 seconds.
No Ink cartridge or Ink end (color)	---	---	On	---	Install a new color ink cartridge by pressing the load/eject button for 3 seconds.
Maintenance request	Blink	Blink	Blink	Blink	Change the waste ink drain tank and reset the EEPROM.
Fatal error	Blink	On	On	Blink	Turn the printer off and on again. If the printer does not recover, repair the appropriate part.

### 3.2 Unit Level Troubleshooting

When a problem occurs, you can identify the defective unit according to the symptoms exhibits. The table below lists the symptoms of certain problems. Once the problem is identified, refer to the flowchart that corresponds to the problem.

**Table 3-4. Symptom and Problem**

Symptom	Problem	Flowchart No.
Printer does not operate at power on.	LEDs do not light. Printer mechanism does not operate.	Flowchart 1
Error is detected	Error is indicated by LED indication.	Flowchart 2
Failure occurs during printing.	Printing is not performed. Abnormal printing (missing dot, etc.) Print quality is poor.	Flowchart 3
Printer does not feed paper correctly.	No paper is fed. Paper feed is irregular. Paper jam occurs.	Flowchart 4
Control panel operation is abnormal.	No response to button access.	Flowchart 5

#### 3.2.1 Printer does not operate at power on.

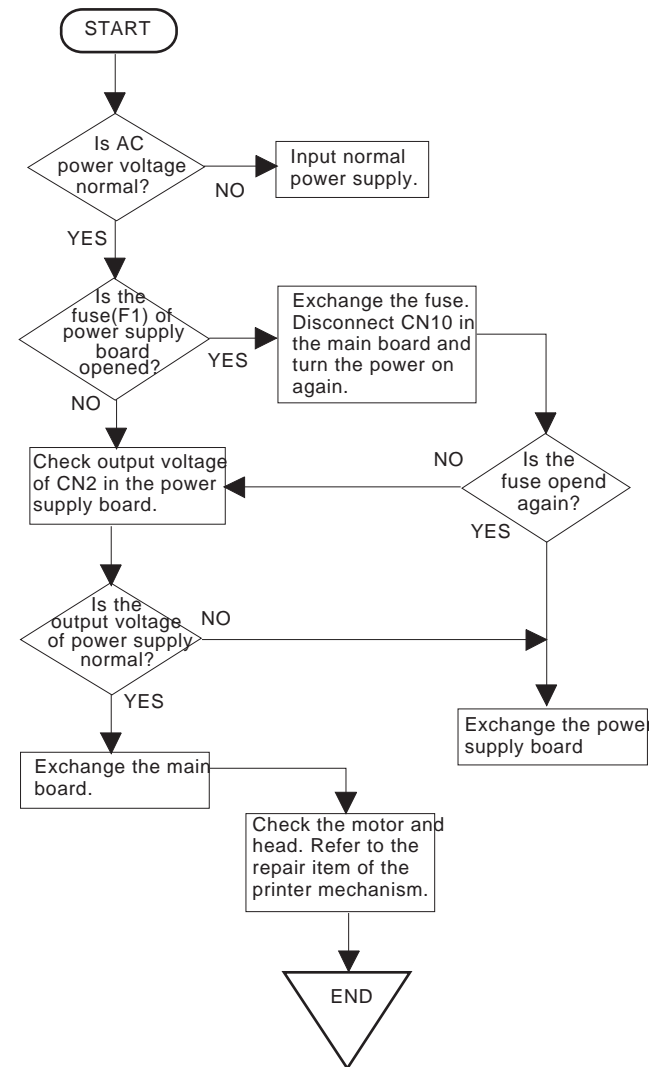

**Flowchart 1**

### 3.2.2 Error is detected

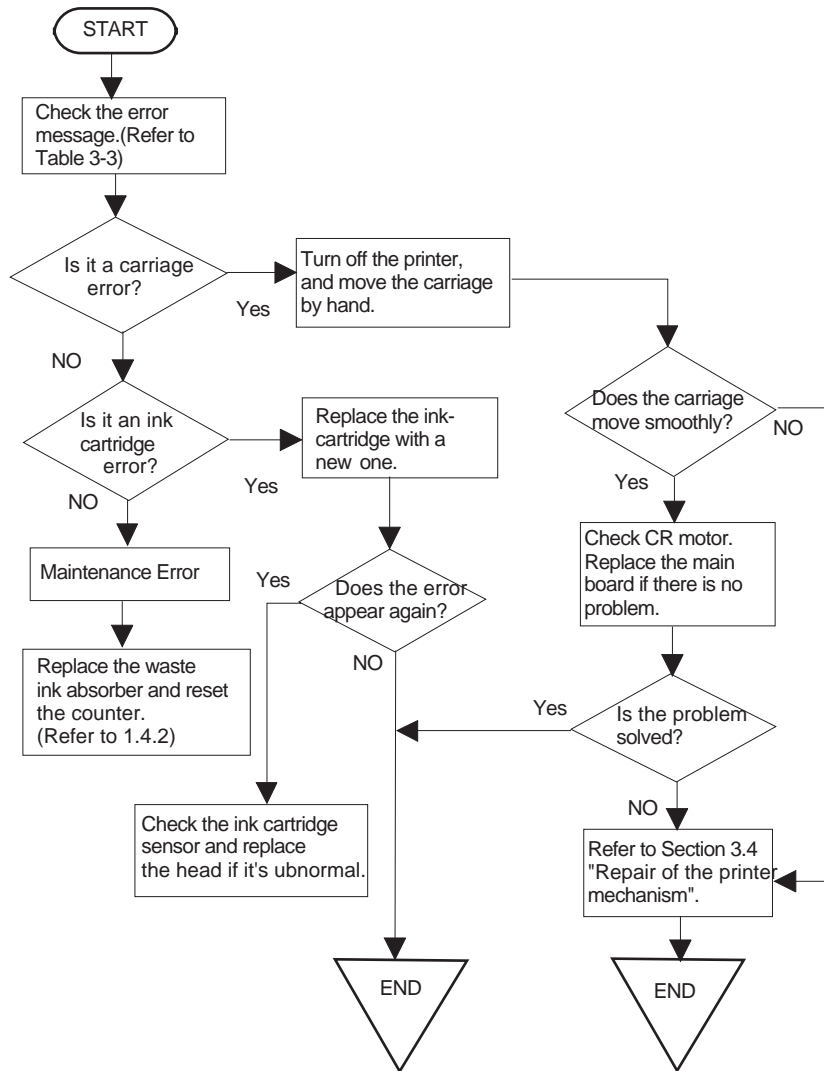

Flowchart 2

### 3.2.3 Failure occurs during printing

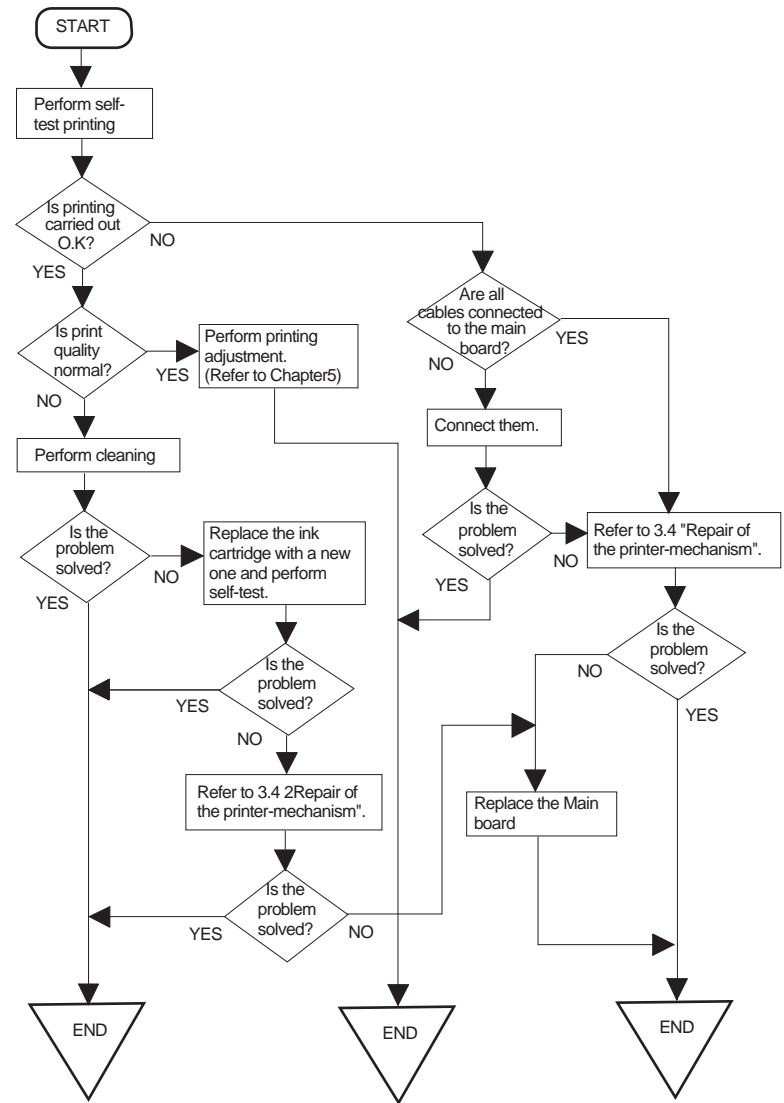

Flowchart 3

### 3.2.4 Printer does not feed paper correctly.

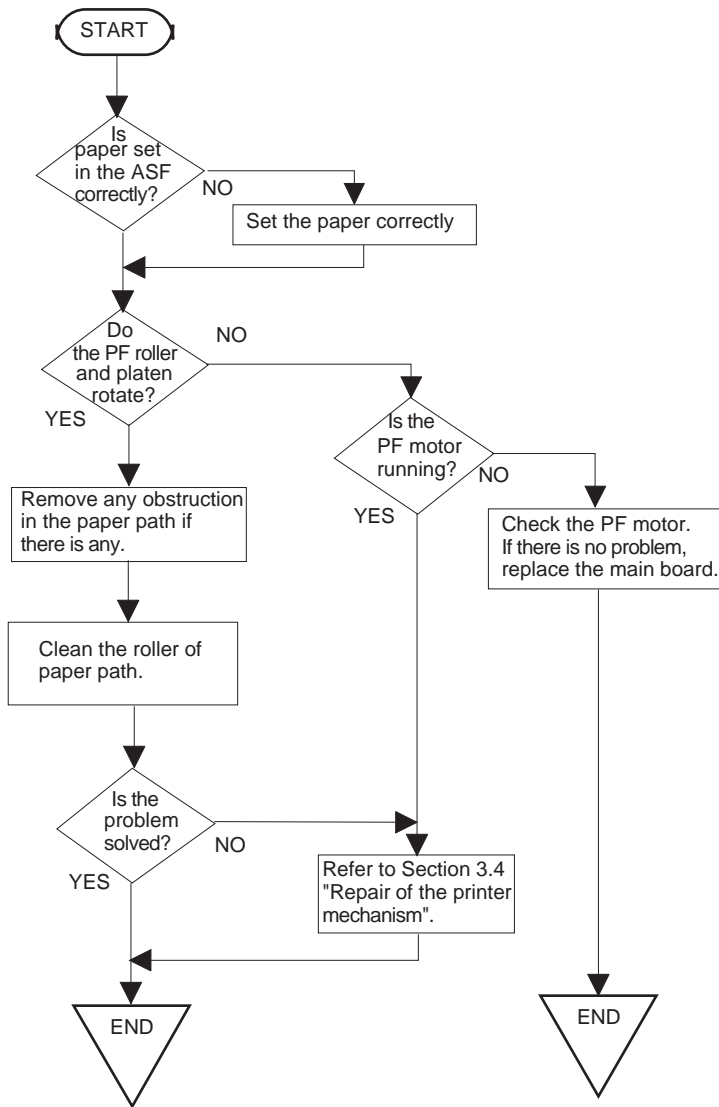

Flowchart 4

### 3.2.5 Control panel operation is abnormal.

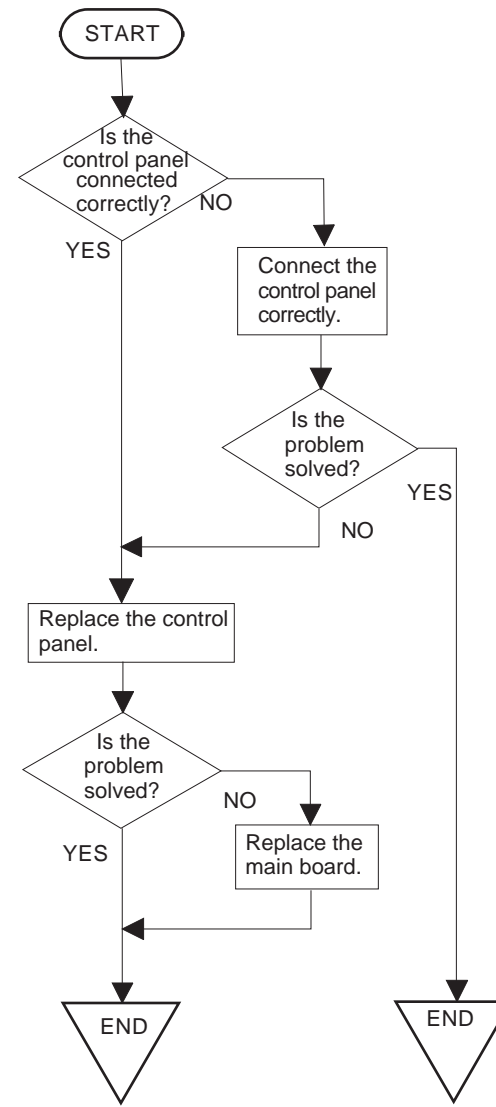

Flow Chart 5

### 3.3 Unit Repair of Power Supply Board

---

**Note:**

The power supply board equipped with each printer is as follows:

- Stylus Color 440: C206 PSB/PSE
- Stylus Color 640: C206 PSB/PSE
- Stylus Color 740: C257 PSB/PSE

This section describes the problems related to the power supply board. The table below provides various symptoms, likely causes, and checkpoints. The checkpoints refer to waveforms, resistance, and other values to check to evaluate the operation of each component.



Table 3-5. Repair of the C206/C257 PSB/PSE Board

Symptom	Condition	Cause	Checkpoint	Solution
The printer does not operate at all.	+42V line is dead.	F1 is open.	Check F1 by using a tester. 	Replace F1.
		Transformer coils are open.	Check the waveform at the drain of Q1.	Replace T1.
		Switching FET (Q1) is dead.	Check drain side. 	Replace Q1.
		Feed back transistor (Q2, Q3) are dead.	Check collector side. 	Replace Q2 or Q3.
		+42 V line is abnormal.	Check the following parts. <ul style="list-style-type: none"> <li>• ZD87, ZD83</li> <li>• ZD51, ZD81–ZD86</li> <li>• PC1</li> </ul>	Replace suitable parts.

Table 3-5. Repair of the C206/C257 PSB/PSE Board

Symptom	Condition	Cause	Checkpoint	Solution
(Continued)  The printer does not operate at all.	+5V line is dead.	IC51 (L4962E/FA3635P) is dead.  <b>Note:</b> <ul style="list-style-type: none"> <li>L4962 is used for Stylus Color 440/640.</li> <li>FA3635P is used for Stylus Color 740.</li> </ul>	<b>Stylus Color 440/640:</b> <ul style="list-style-type: none"> <li>Check the oscillation (Pin 5) waveform of IC51.</li> </ul> <p>(Pin 5)</p> 	Replace IC51.
			<ul style="list-style-type: none"> <li>Check the switching (Pin 7) waveform of IC51.</li> </ul> <p>(Pin 7)</p> 	
		IC51 (L4962E/FA3635P) is dead.  <b>Note:</b> <ul style="list-style-type: none"> <li>L4962 is used for Stylus Color 440/640.</li> <li>FA3635P is used for Stylus Color 740.</li> </ul>	<b>Stylus Color 740:</b> <ul style="list-style-type: none"> <li>Check the switching (Pin 8) waveform of IC51.</li> </ul> <p>(Pin 8)</p> 	Replace IC51.

## 3.4 Unit Repair of the Main Board

---

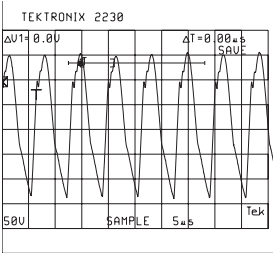
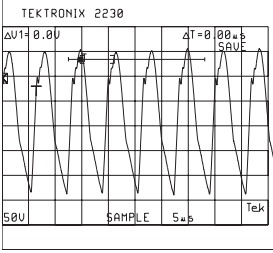
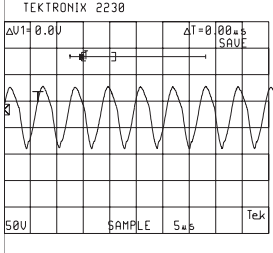
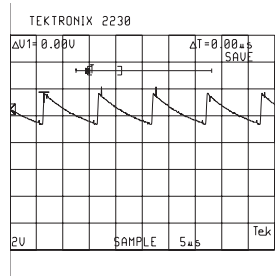
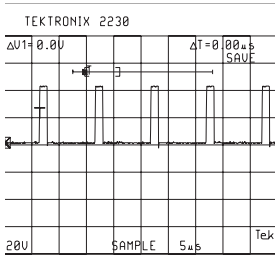
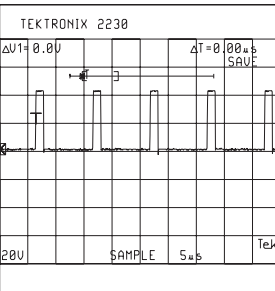
**Note:**

*The Main board equipped with each printer is as follows:*

- Stylus Color 440: C206MAIN-B, C255MAIN
- Stylus Color 640: C256MAIN
- Stylus Color 740: C257MAIN

This section describes the problems related to the main controller board. The table below provides various symptoms, likely causes, and checkpoints. The check points refer to waveforms, resistance, and other values to check to evaluate the operation of each component.

Table 3-6. Unit Repair of Main Board

Symptoms	Condition	Cause	Check Point	Solution
The printer does not operate at all.	CPU does not operate.	The reset circuit does not operate.	<b>Stylus Color 440, 640:</b> Check the waveform of the +5V and /Reset signal (IC9=Pin 7, 6-pin) 	Replace IC9.
			<b>Stylus Color 740:</b> Check the waveform of the +5V and /Reset signal (IC8=2-pin, Pin 7) 	Replace IC8.
		Control ROM, D- RAM, and Mask ROM are not selected correctly or it's dead.	<b>Stylus Color 440:</b> If you can not find the waveform at 88-pin of IC1, the IC1 is dead, and if you can not find it at 20-pin of IC3 or 26-pin of IC4, the IC3 or IC4 is dead.	<b>Stylus Color 440:</b> Replace IC1, IC3, or IC4.
		<b>Stylus Color 640:</b> If you can not find the waveform at 97-pin of IC1, the IC1 is dead, and if you can not find it at 13-pin of IC3, the IC3 is dead. If you can not find the waveform at 98, 99-pin of IC1, the IC1 is dead, and if you can not find it at 27-pin of IC5, and at 14-pin of IC6, the IC5 or IC6 is dead.	<b>Stylus Color 640:</b> Replace IC1, IC3, IC5, or IC6	
(Continues to the next page.)	(Continues to the next page.)	(Continues to the next page.)		

Table 3-6. Unit Repair of Main Board

Symptoms	Condition	Cause	Check Point	Solution
(Continued) The printer does not operate at all.	(Continued) CPU does not operate.	(Continued)	<p><b>Stylus Color 740:</b></p> <ul style="list-style-type: none"> <li>If you can not find the waveform at 2, 128, 127-pin of IC1, the IC1 is dead, and if you can not find the waveform at 85-pin of IC2, the IC2 is dead.</li> <li>If you can not find the waveform at 13-pin of IC3, the IC3 is dead.</li> <li>If you can not find the waveform at 27-pin of IC4 or IC5, the IC4 or IC5 is dead.</li> <li>If you can not find the waveform at 14-pin of IC6, the IC6 is dead.</li> </ul>	<p><b>Stylus Color 740:</b></p> <ul style="list-style-type: none"> <li>Replace IC1, or IC2.</li> <li>Replace IC3.</li> <li>Replace IC4 or IC5.</li> <li>Replace IC6.</li> </ul>
		<p><b>Stylus Color 440:</b> CRU2 is dead.</p> <p><b>Stylus Color 640:</b> CR2 is dead.</p> <p><b>Stylus Color 740:</b> CR1 or IC2 is dead.</p>	<p><b>Stylus Color 440, 640:</b> Check the waveform at 27,28-pin of IC1.</p> <p><b>Stylus Color 740:</b> Check the waveform at 118 or 119-pin of IC2. And check the output waveform at 91-pin of IC2.</p> 	<p><b>Stylus Color 440, 640:</b> Replace CRU2 or CR2.</p> <p><b>Stylus Color 740:</b> Replace CR1 or IC2.</p>
The carriage does not operate normally.	Carriage motor does not operate at all or it occurs a abnormal noise.	IC2 is dead.	<p><b>Stylus Color 440:</b> Check the waveform at 25, 18 pin of IC14.</p> <p><b>Stylus Color 640:</b> Check the waveform at 43, 26 pin of IC14.</p> <p><b>Stylus Color 740:</b> Check the waveform at 27, 16 pin of IC11.</p> 	Replace IC2.
(Continues to the next page.)	(Continues to the next page.)			

Table 3-6. Unit Repair of Main Board

Symptoms	Condition	Cause	Check Point	Solution
(Continued) The carriage does not operate normally.	(Continued) Carriage motor does not operate at all or it occurs a abnormal noise.	<b>Stylus Color 440, 640:</b> IC14 is dead.  <b>Stylus Color 740:</b> IC11 is defective.	<b>Stylus Color 440:</b> Check the waveform at 6-9 pin of IC14.  <b>Stylus Color 640:</b> Check the waveform at 3, 6, 18, 21 pin of IC14.  <b>Stylus Color 740:</b> Check the waveform at 6-9 pin of IC11.	 <b>Stylus Color 440, 640:</b> Replace IC14.  <b>Stylus Color 740:</b> Replace IC11.
Printing is abnormal.	Printing is not execute.	Trapezoidal waveform does not output.	<b>Stylus Color 440:</b> Check the trapezoidal waveform at 3-pin of Q7 or Q9 on C206Main-B, C255 main board.  <b>Stylus Color 640:</b> Check the trapezoidal waveform at 3-pin of Q7 or Q9 on C256 Main board.  <b>Stylus Color 740:</b> Check the trapezoidal waveform at 3-pin of Q2 or Q3 on C257 Main board.	<b>Stylus Color 440:</b> Replace IC6, Q7, or Q9.  <b>Stylus Color 640:</b> Replace IC7, Q7, or Q9.  <b>Stylus Color 740:</b> Replace IC14, Q2, or Q3.
		IC2 is dead.	<b>Stylus Color 440, 640:</b> Check the clock signal of trapezoidal from IC2. (at 80 pin of IC2)  <b>Stylus Color 740:</b> Check the clock signal of trapezoidal from IC2. (at 174 pin of IC2)	 Replace IC2.

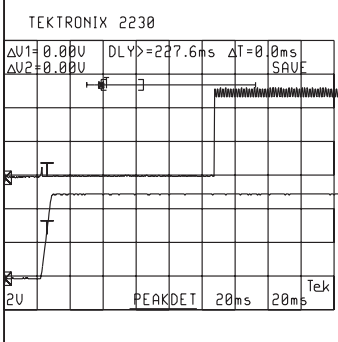
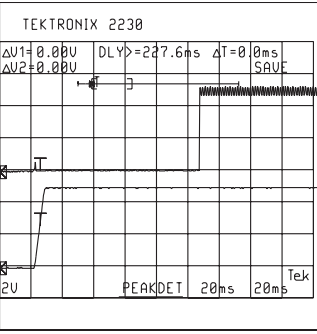
Table 3-6. Unit Repair of Main Board

Symptoms	Condition	Cause	Check Point	Solution	
Paper feed operation is abnormal.	Paper feed motor does not work.	IC2 is dead.	<p><b>Stylus Color 440:</b> Check the waveform at 25, 18 pin of IC14.</p> <p><b>Stylus Color 640:</b> Check the waveform at 43, 26 pin of IC16.</p> <p><b>Stylus Color 740:</b> Check the waveform at Pin 7 of IC12 and IC13.</p>		Replace IC2
		<p><b>Stylus Color 440, 640:</b> IC15 is dead.</p> <p><b>Stylus Color 740:</b> IC12 or IC13 is dead.</p>	<p><b>Stylus Color 440:</b> Check the output waveform of at 6-9 pin of IC15.</p> <p><b>Stylus Color 640:</b> Check the output waveform of at 3, 6, 18, 21 pin of IC15.</p> <p><b>Stylus Color 740:</b> Check the output waveform of at 10, 15 pin of IC12 and IC13.</p>		<p><b>Stylus Color 440, 640:</b> Replace IC15</p> <p><b>Stylus Color 740:</b> Replace IC12, IC13.</p>

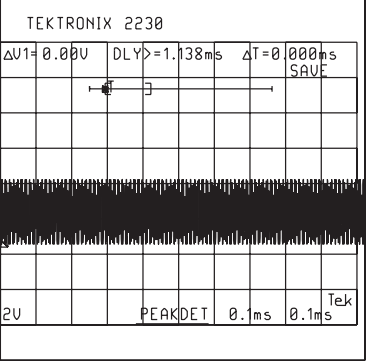
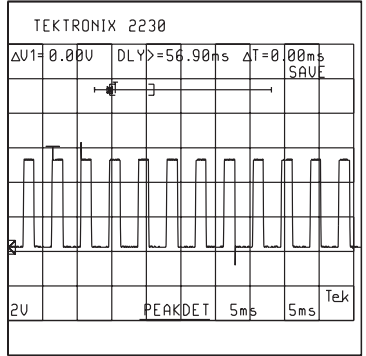
## 3.5 Repair of the Printer Mechanism

This section provides instruction for repairing the printer mechanism. It describes various problems, symptom, likely causes, checkpoints, and solutions. Select appropriate symptom from the table and check each parts and its function as described in the checkpoint.

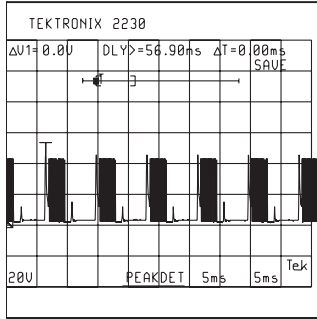
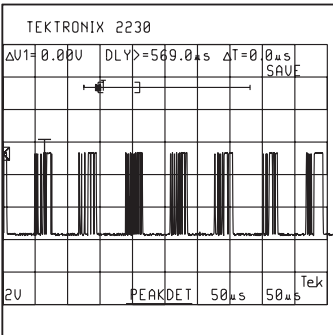
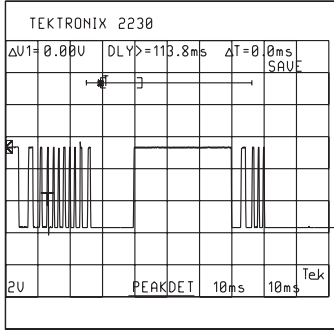
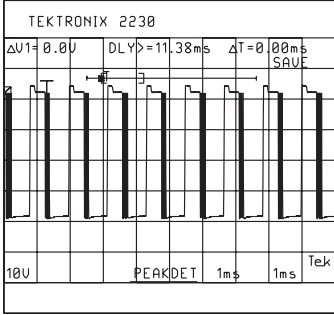
**Table 3-7. Repair of the Printer Mechanism**

<b>Symptom</b>	<b>Condition</b>	<b>Cause</b>	<b>Check Point</b>	<b>Solution</b>
Abnormal pump mechanism operation	Abnormal PF motor operation when the power is turned on.	Foreign substances are loaded in the PF gears.	Manually drive the platen drive gear and check it if it rotates normally.	Remove any foreign substances.
		The PF motor is defective. (Refer to Table5-1)	Check the inner coil resistance and see if there is any disconnection of the coil.	Exchange the PF motor.
Ink is not absorbed or is poorly absorbed.	Used ink does not go through the waste ink tube.	The pump tube is crashed.	Check the tube visually.	Fix the crashed part by the airgun.
		Capping rubber is damaged or deformed.	Check the capping rubber visually.	Replace the cap mechanism.
		The tube is out of the cap.	Check if the tube is out of the cap visually.	Connect the tube properly.
		Pump bulb is not closed at absorption.	Check the bulb operation visually.	Replace the cap mechanism.
Abnormal carriage operation.	Abnormal carriage operation at power on.	Foreign substance in the CR drive gear.	Check visually if there is any substances or not.	Remove any foreign substances.
		CR motor is defective.	Check the inner coil resistance and see if there is any disconnection of the coil.	Replace the CR motor.
	Abnormal carriage operation during printing.	Carriage movement is not smooth.	Check whether the carriage moves smoothly when moved manually.	Clean and lubricate the carriage guide axis.
			Check tension of the timing belt.	Adjust tension mechanism or exchange it.
			Check if there is any foreign substances in the carriage path.	Remove any foreign substances.
	Printing is not performed.	The carriage moves, but no printing is performed.	Head FFC is out of connection.	Check if the head FFC on the board or carriage is connected surely.
The FFC is disconnected inside.			Check the FFC by using a tester.	Replace the FFC.
I/C is defective.			Install a new I/C and perform the self-test.	Replace I/C.
Head unit is defective.			If the condition does not improve even after 2or 3 times cleaning operation, replace the head unit and perform the self-test.	Replace the head unit.



Table 3-7. Repair of the Printer Mechanism

Symptom	Condition	Cause	Check Point	Solution
Abnormal printing	Only a particular dot causes abnormal printing.	Print head surface is not clean. (dot missing)	Perform the cleaning operation several times and check printing.	Perform the cleaning.
		The head unit is defective.	Perform the cleaning operation several times and check printing.	If condition does not improve even after the cleaning, replace the head.
		Capping absorber is touching the head surface.	Check the head absorber visually.	Replace the head absorber if it is deformed.
	A dot is not printed occasionally.	Print head surface is not clean. (dot-missing)	Perform the cleaning operation several times and check printing.	Perform the cleaning.
		The head FFC is disconnected inside.	Check the FFC by using a tester.	Replace the head FFC.
		The head FFC is out of connection.	Check if the head FFC on the board or carriage is connected surely.	Connect the FFC properly.
		The head unit is defective.	Perform the cleaning operation several times and check printing.	If condition does not improve even after the cleaning, replace the head.
		I/C is defective.	Install the new I/C and perform self-test.	Replace I/C.
	Black specks or dots.	The head FFC is out of connection.	Check if the head FFC on the board or carriage is connected surely.	Connect the FFC properly.
		The head unit is defective.	Check connection with the head FFC.	Replace the head if there is no connection problem with the FFC.
	A vertical line is not aligned.	Bi-directional alignment is not adjusted.	Perform Bi-D adjustment.	Refer to Chapter4.
	White line appears in the image data.	Head angle is not correct.	Perform head angle adjustment.	Refer to Chapter4.
		Platen gap is not correct.	Perform platen gap adjustment.	Refer to Chapter4.
		Dot shooting direction is tilted because head surface is not clean	Perform the cleaning operation several times and check printing.	Perform the cleaning operation.
		I/C is defective.	Install a new I/C and perform the self-test.	Replace I/C.
Head unit is defective.		Perform the cleaning operation several times and check printing.	Replace the head unit.	

Table 3-7. Repair of the Printer Mechanism

<b>Symptom</b>	<b>Condition</b>	<b>Cause</b>	<b>Check Point</b>	<b>Solution</b>
Abnormal paper feeding.	Paper is not fed.	Friction of the PF roller.	Check if the PF roller rotates when paper is not fed.	Clean the PF roller by the cleaning sheet. Replace the PF roller if it does not recover.
		Abnormal operation of the hopper.	Check movement of the ASF hopper visually.	Replace ASF.
		Malfunction of ASF drive change-over.	Check if the ASF gear rotates visually.	Replace gears of the ASF drive change-over.
		Friction of the PF roller.	Check if the PF roller slips during paper feeding.	Clean the PF roller by the cleaning sheet. Replace the PF roller if it does not recover.
Printer stops during initialization.	Fatal error appears.	ASF sensor is defective.	Check the signal level of the ASF sensor. (Refer to Table 5-2)	Replace ASF sensor.
		PE sensor is defective.	Check the signal level of the PE sensor. (Refer to Table 5-2)	Replace PE sensor.
		HP sensor is defective.	Check the signal level of the HP sensor. (Refer to Table 5-2.)	
		Head FFC is disconnected.	Check if the head FFC is connected.	Connect the head FFC.
		CR motor is defective.	Check the CR motor cable is connected.	Replace the CR motor if there is no problem in the cable connection.
		PF motor is defective.	Check if the PF motor cable is connected.	Replace the PF motor if there is no problem in the cable connection.

**CHAPTER**

**4**

**DISASSEMBLY AND ASSEMBLY**

## 4.1 Overview

---

This chapter describes procedures for disassembling the main components of EPSON Stylus Color 440/640/740. Unless otherwise specified, disassembly units or components can be reassembled by reversing the disassembly procedure. Therefore, no assembly procedures are included in this chapter. Precautions for any disassembly or assembly procedure are described under the heading "CHECK POINT". Any adjustments required after disassembling the units are described under the heading "REQUIRED ADJUSTMENT".

### 4.1.1 Precautions for Disassembling the Printer

See the precautions given under the heading "WARNING" and "CAUTION" in the right column and the following page, respectively, when disassembling or assembling EPSON Stylus Color 440/640/740.



- **Disconnect the power cable before disassembling or assembling the printer.**
- **Wear protective goggles to protect your eyes from ink. If ink gets in your eye, flush the eye with fresh water and see a doctor immediately.**
- **If ink comes into contact with your skin, wash it off with soap and water. If irritation occurs, contact a physician.**
- **A lithium battery is installed on the main board of this printer. Be sure to observe the following instructions when serving the battery:**
  - Keep the battery away from any metal or other batteries so that electrodes of the opposite polarity do not come in contact with each other.
  - Do not heat the battery or put it near fire.
  - Do not solder on any part of the battery. (Doing so may result in leakage of electrolyte from the battery, burning or explosion. The leakage may affect other devices close to the battery.)
  - Do not charge the battery. (An explosion may be generated inside the battery, and cause burning or explosion.)
  - Do not dismantle the battery. (The gas inside the battery may hurt your throat. Leakage, burning or explosion may also be resulted.)
  - Do not install the battery in the wrong direction. (This may cause burning or explosion.)
- **Danger of explosion if the battery is incorrectly replaced. Replace only with the same or equivalent type recommended by the manufacture. Dispose the used batteries according to government's law and regulations.**



Risque d'explosion si la pile est remplacée incorrectement. Ne remplacer que par une pile du même type ou d'un type équivalent recommandé par le fabricant. Eliminer les piles déchargées selon les lois et les règles de sécurité en vigueur.



- Never remove the ink cartridge from the carriage unless this manual specifies to do so.
- When transporting the printer after installing the ink cartridge, be sure to pack the printer for transportation without removing the ink cartridge.
- Use only recommended tools for disassembling, assembling or adjusting the printer.
- Apply lubricants and adhesives as specified. (See Chapter 6 for details.)
- Make the specified adjustments when you disassemble the printer. (See Chapter 4 for details.)
- When assembling, if an ink cartridge is removed and needs to be installed again, be sure to install a new ink cartridge because of the following reasons;
  - Once the ink cartridge mounted on the printer is removed, air comes into and creates bubbles in the cartridge. These bubbles clog ink path and cause printing malfunction.
  - If an ink cartridge in use is removed and is reinstalled, ink quantity will not be detected correctly since the counter to check ink consumption is cleared.
- Because of the reasons above, make sure to return the printer to the user with a new ink cartridge installed.

## 4.1.2 Tools

Table 4-1 lists the tools recommended for disassembling, assembling, or adjusting the printer. Use only tools that meet these specifications.

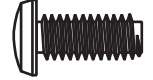
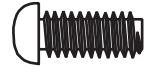

Table 4-1. Tool List

Tools	Commercially Available	Code
(+) Driver No.2	O.K.	B743800200
(+) Driver No.1	O.K.	B743800400
Tweezers	O.K.	B741000100
Hexagon Box Driver (Opposite side:5.5mm)	O.K.	B741700100

### 4.1.3 Specification for Screws

Table 4-2 shows screw specifications. During assembly and disassembly, make sure that the specified types of screws are used at proper locations, referring to the table below. Note that the screw numbers described in the manual correspond to the numbers in the table.

**Table 4-2. Screw Characteristic**

No.	Body	Name	Size
1		+Bind, S-tight	M3X6
2		+Bind, S-tight	M3X10
3		+Bind, P-tight (CBP tight)	M3X6
4		+Bind, P-tight (CBP tight)	M3X10
5		+Bind, P-tight (CBP tight)	M3X8
6		+Pan head (CP)	M3X4
7		+Bind, S-tight, Sems R2(CBS Sems)	M3X6

#### 4.1.4 Service Checks After Repair

Before returning the printer after servicing, use the check list below, which enables you to keep record of servicing and shipping more efficiently.

**Table 4-3. Inspection Checklist for the Repaired Printer**

Category	Component	Item to check	Is Check Required?
Printer units	Self-test	Is the operation normal?	<input type="checkbox"/> Checked / <input type="checkbox"/> Not necessary
	On-line test	Was the on-line test successful?	<input type="checkbox"/> Checked / <input type="checkbox"/> Not necessary
	Print head	Is ink ejected normally from all nozzles?	<input type="checkbox"/> Checked / <input type="checkbox"/> Not necessary
	Carriage mechanism	Does the carriage move smoothly?	<input type="checkbox"/> Checked / <input type="checkbox"/> Not necessary
		Any abnormal noise during movement?	<input type="checkbox"/> Checked / <input type="checkbox"/> Not necessary
		Any dirt or obstacles around the shaft of carriage guide?	<input type="checkbox"/> Checked / <input type="checkbox"/> Not necessary
		Is the CR motor at the correct temperature (not over heating)?	<input type="checkbox"/> Checked / <input type="checkbox"/> Not necessary
	Paper feeding mechanism	Is paper fed smoothly?	<input type="checkbox"/> Checked / <input type="checkbox"/> Not necessary
		Does paper get jammed?	<input type="checkbox"/> Checked / <input type="checkbox"/> Not necessary
		Does paper get skew during paper feeding?	<input type="checkbox"/> Checked / <input type="checkbox"/> Not necessary
		Are papers multi fed?	<input type="checkbox"/> Checked / <input type="checkbox"/> Not necessary
		Does the PF motor get overheated?	<input type="checkbox"/> Checked / <input type="checkbox"/> Not necessary
		Abnormal noise during paper feeding?	<input type="checkbox"/> Checked / <input type="checkbox"/> Not necessary
Is the paper path clear of all obstructions?		<input type="checkbox"/> Checked / <input type="checkbox"/> Not necessary	
Adjustment	Specified adjustment items	Are adjusted conditions all right?	<input type="checkbox"/> Checked / <input type="checkbox"/> Not necessary
Lubricant	Specified lubricated item	Is lubrication applied to the specified locations?	<input type="checkbox"/> Checked / <input type="checkbox"/> Not necessary
		Is the quantity of lubrication adequate?	<input type="checkbox"/> Checked / <input type="checkbox"/> Not necessary
Function	ROM version	Newest version:	<input type="checkbox"/> Checked / <input type="checkbox"/> Not necessary
Shipment package	Ink cartridges	are the ink cartridges installed correctly?	<input type="checkbox"/> Checked / <input type="checkbox"/> Not necessary
	Protection conditions during transport	Is all the pointed parts firmly fixed?	<input type="checkbox"/> Checked / <input type="checkbox"/> Not necessary
Others	Attached items	Are all attached items from users included?	<input type="checkbox"/> Checked / <input type="checkbox"/> Not necessary

## 4.2 Disassembly Procedures

The flowchart below shows procedures for disassembly.

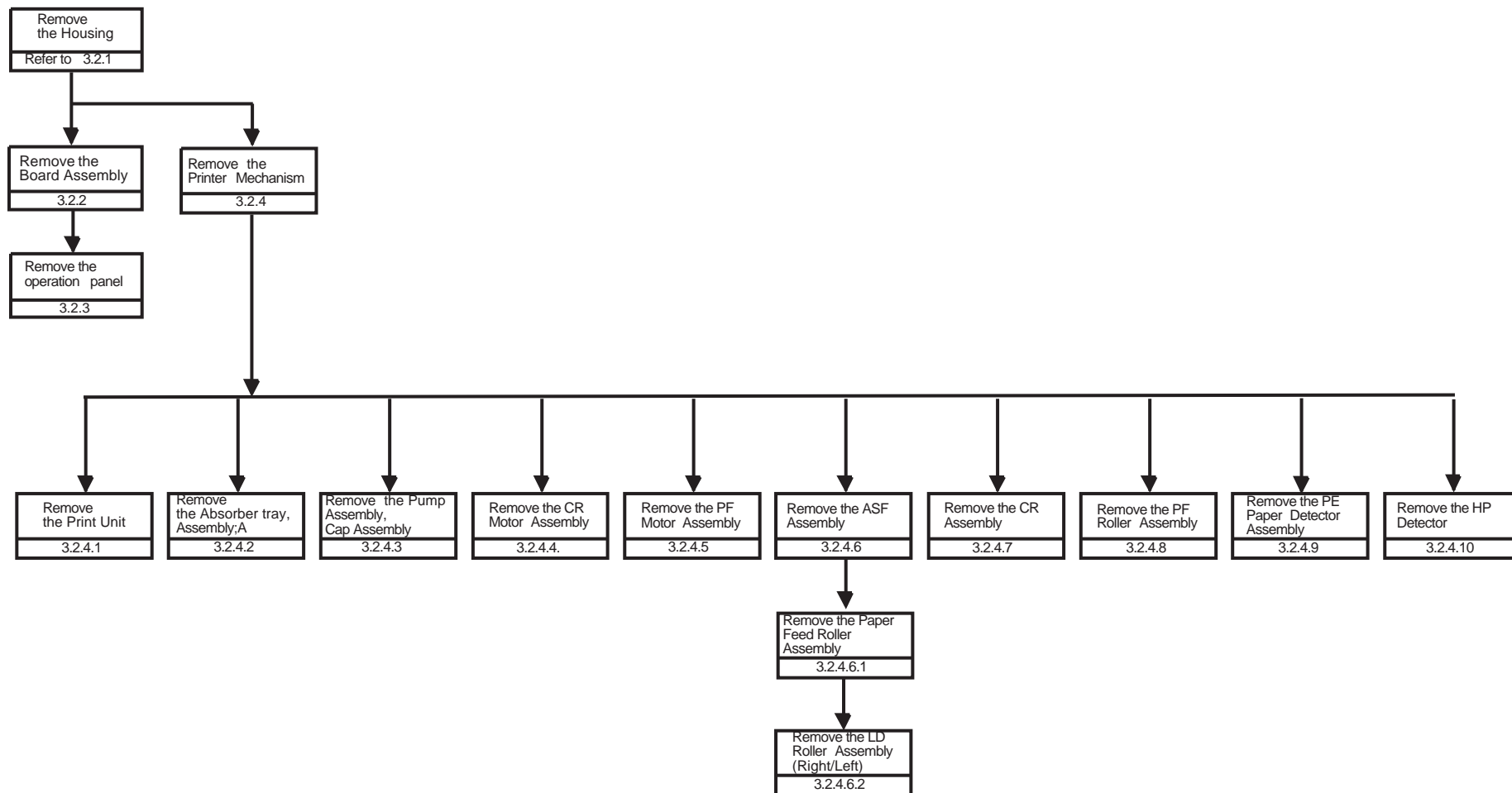

Figure 4-1. Flowchart of Disassembly



## 4.2.1 Removing the Housing

Since the printer mechanism itself structures the bottom part, the printer mechanism appears just by removing the housing.

1. Open the printer cover and turn the PG adjustment lever towards (+) side.
2. Remove 4 screws (No.2) securing the housing, and remove the housing.



**Lift up and remove the housing, pulling it towards you.  
(Since it collides with carriage)**

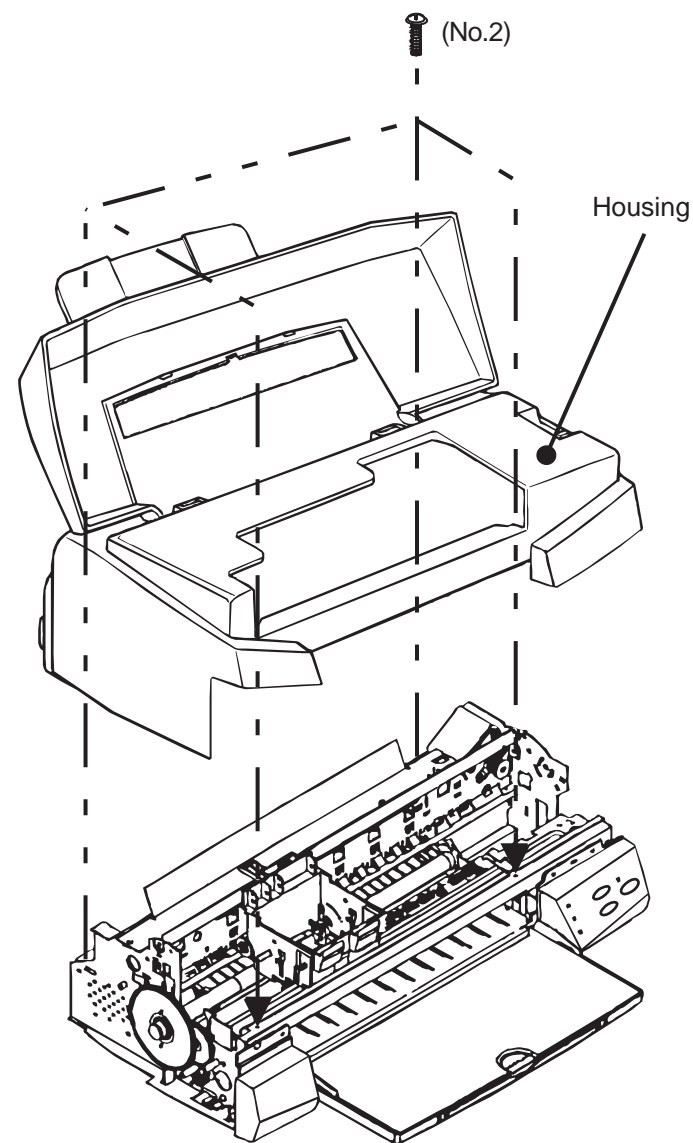

Figure 4-2. Removing the Housing

## 4.2.2 Removing the Board Assembly

Since the main board and power supply circuit board are built in a separate bracket from the printer mechanism, remove the whole bracket from the printer mechanism.

**NOTE:** The main board and power supply board equipped with each printer are as follows

- Stylus Color 440: C206MAIN-B, C255 Main, C206PSB/PSE
- Stylus Color 640: C256MAIN, C206PSB/PSE
- Stylus Color 740: C257MAIN, C257PSB/PSE

1. Remove the housing. (Refer to 3.2.2)
2. Remove the 5 screws (No.1) securing the "M/B Shield plate" on the printer mechanism.
3. Pull out the "M/B Shield Plate" a little bit and remove cables which are hung on the A and B holders as you can see in the figure below. Then, take all cables out of connectors on the main board.
  - Stylus Color 440, 640:  
CN11 black, CN4 yellow, CN5 white, CN3 black, CN6/7 white, CN8 FFC black
  - Stylus Color 740:  
CN11 black, CN4 white, CN5 yellow, CN6 black, CN 7/8 white, CN9 FFC gray
4. After removing all the cables from the main board, detach the "Shield plate M/B" completely from the printer mechanism.
5. When removing each board unit from the "M/B Shield plate", remove the screws securing each unit and shield plate. [main board: 10 screws (7 No.1 screws, 3 No.6 screws), power supply board: 4 screws (No.1)] Refer to the next page for the figure. Also, when removing the power supply board, remove the cable connecting to the main board (CN6 with lock device).



- Since the connectors CN 6,7,10(for 440, 640) and CN7,8,10(for 740) have connector locks, be sure to release the locks before removing the cables. Also, make sure to lock when connecting these cables.
- When connecting cables to the connectors, the cables never cross with each other in this printer. So, if there are two connectors sitting next to each other, the cable on the right should be connected to the right connector and the cable on the left should be connected to the left one



Be sure to perform the following adjustments when the Main board is replaced;

1. Head voltage ID Input (Refer to Chapter 5.)
2. Bi-D adjustment (Refer to Chapter 5.)

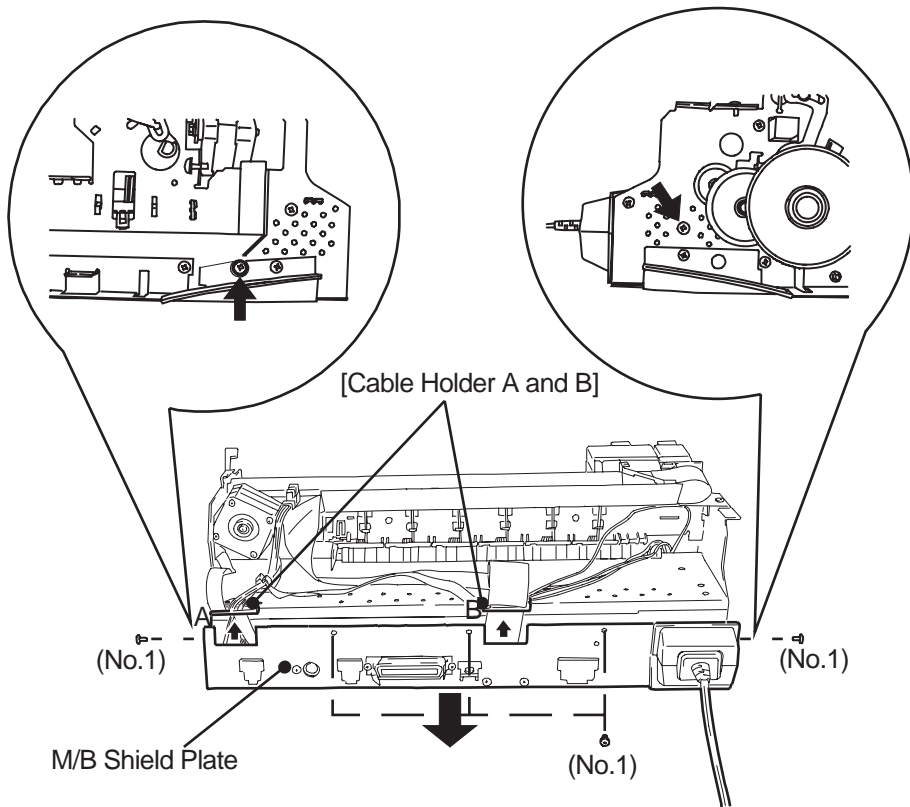

Figure 4-3. Removing the M/B Shield Plate

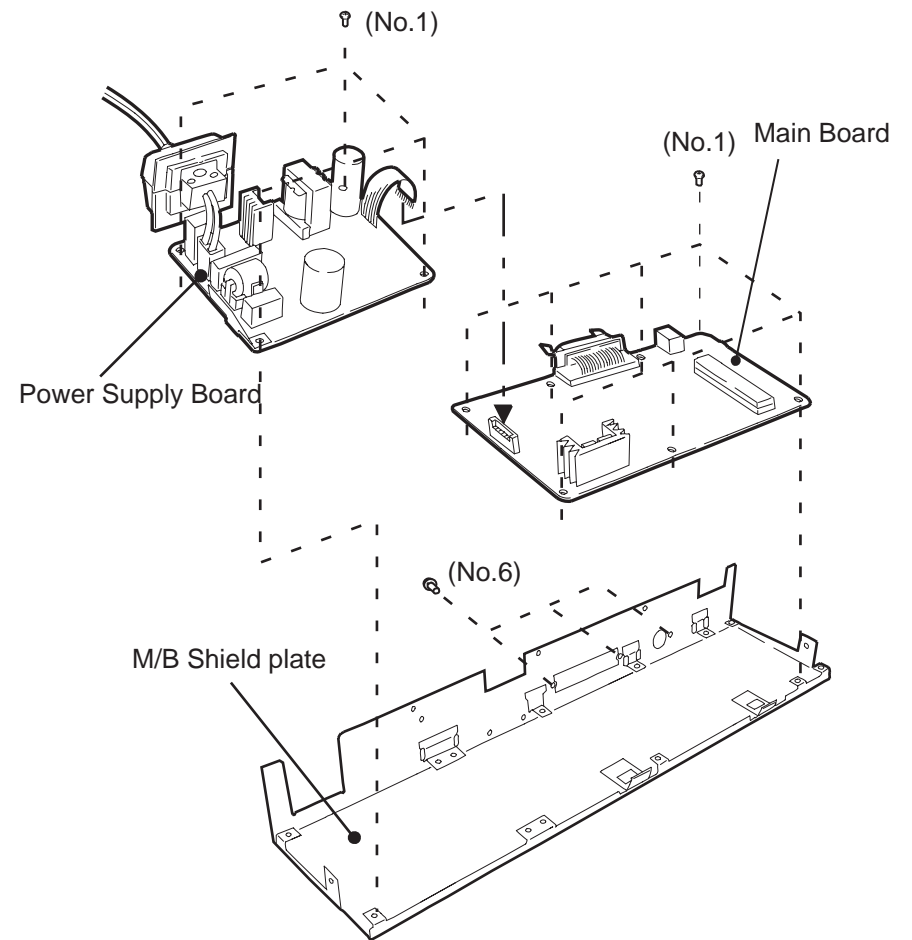

Figure 4-4. Removing the Boards

### 4.2.3 Removing the Operation Panel

The panel board equipped with each printer is as follows:

- Stylus Color 440/640: C206PNL
- Stylus Color 740: C209PNL

1. Remove the housing. (Refer to Section 4.2.1.)
2. Remove two screws (No.1) securing the operation panel and disconnect the operation panel from the printer mechanism.
3. Remove one screw (No.1) and detach the left panel housing.
4. Remove screws (No.3) securing the panel board assembly and remove C206/209 PNL board from the panel assembly.
5. Disconnect the FFC from the connector on the C206/209 PNL board.



**Removing the operation panel also separates the stacker assembly, since the operation panel is attached to the stacker assembly.**

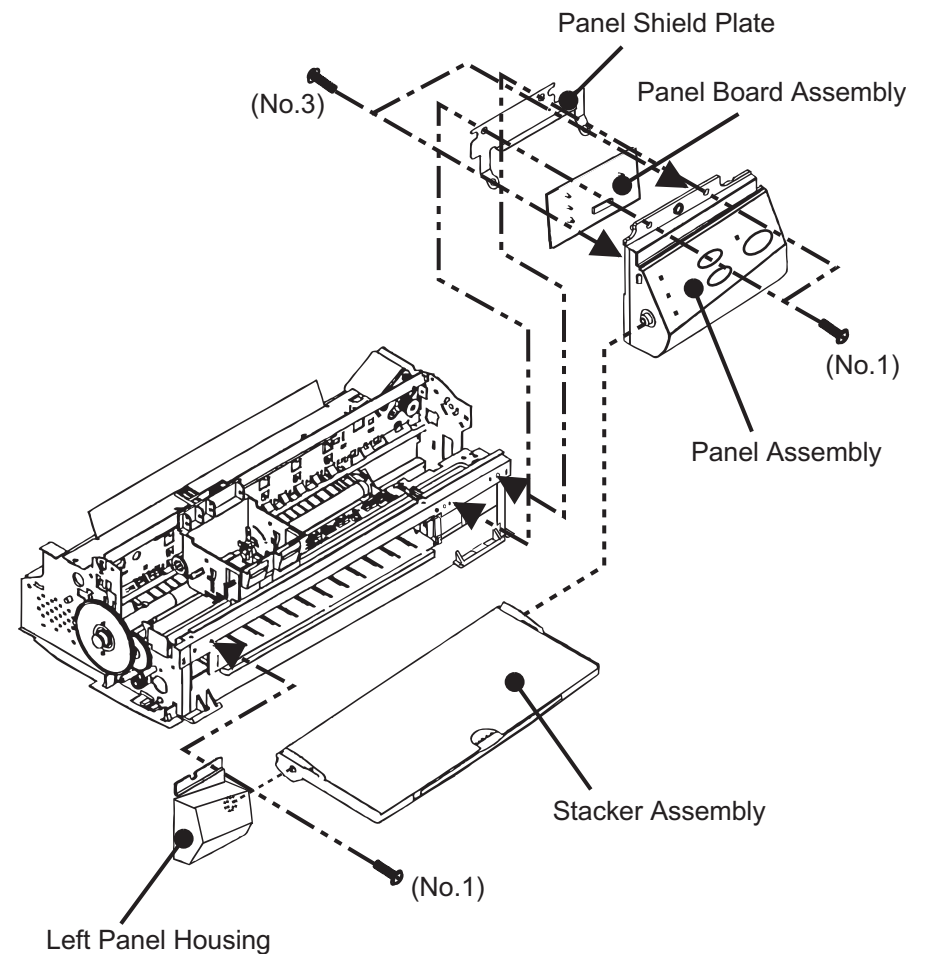

**Figure 4-5. Removing the Operation Panel**

## 4.2.4 Disassembling the Printer Mechanism

Since Stylus Color 440/640/740 do not have the lower housing, the printer mechanism part should already appear by now. Therefore, this section explains procedures for disassembling the major parts or units of the printer mechanism.

### 4.2.4.1 Removing the Print Head Unit

1. Remove the housing. (Refer to Section 4.2.1.)
2. Rotate the flat gear 67.2 towards yourself (front) and release the carriage lock mechanism. Then move the carriage to the left edge.
3. Take both black and color ink cartridges out of the printhead unit.
4. Remove the blue covers for black and color ink cartridges from the carriage assembly.
5. Remove the torsion spring 49 and one screw (No.3) and take the fastener head out.
6. Remove the FFC being placed on the carriage assembly, and remove the printhead unit from the carriage.
7. Disconnect the FFC from the connector on the drive board built in the printhead unit.

See the following pages for the figures below:

Figure 4-6, "Removing the Print Head"

Figure 4-7, "Installing the Printhead"



- Make sure that the earth board is installed to the carriage correctly. (There are 2 pins to determine the location.)
- When you install the printhead to the carriage, make sure that the location pin on the carriage side is placed in the notch of the printhead.



- Since the ink cartridge once taken out can not be used again, be sure to install a new ink cartridge when you return the printer to the user.
- When you return the printer to the user, be sure to pack the printer for transportation with a new ink cartridge installed and the carriage in the home position when the printer is turned on.



When you replace the printhead unit, perform the following adjustment. (Refer to Chapter 5 for more details.):

1. Initial ink charge (Refer to Chapter 5/Section 5.2.2.3)
2. Head Voltage ID Input (Refer to Chapter 5/Section 5.2.2.7.)
3. Head Angular Adjustment (Refer to Chapter 5/Section 5.2.2.8.)
4. Bi-D Adjustment (Chapter 5 /Section 5.2.2.9)

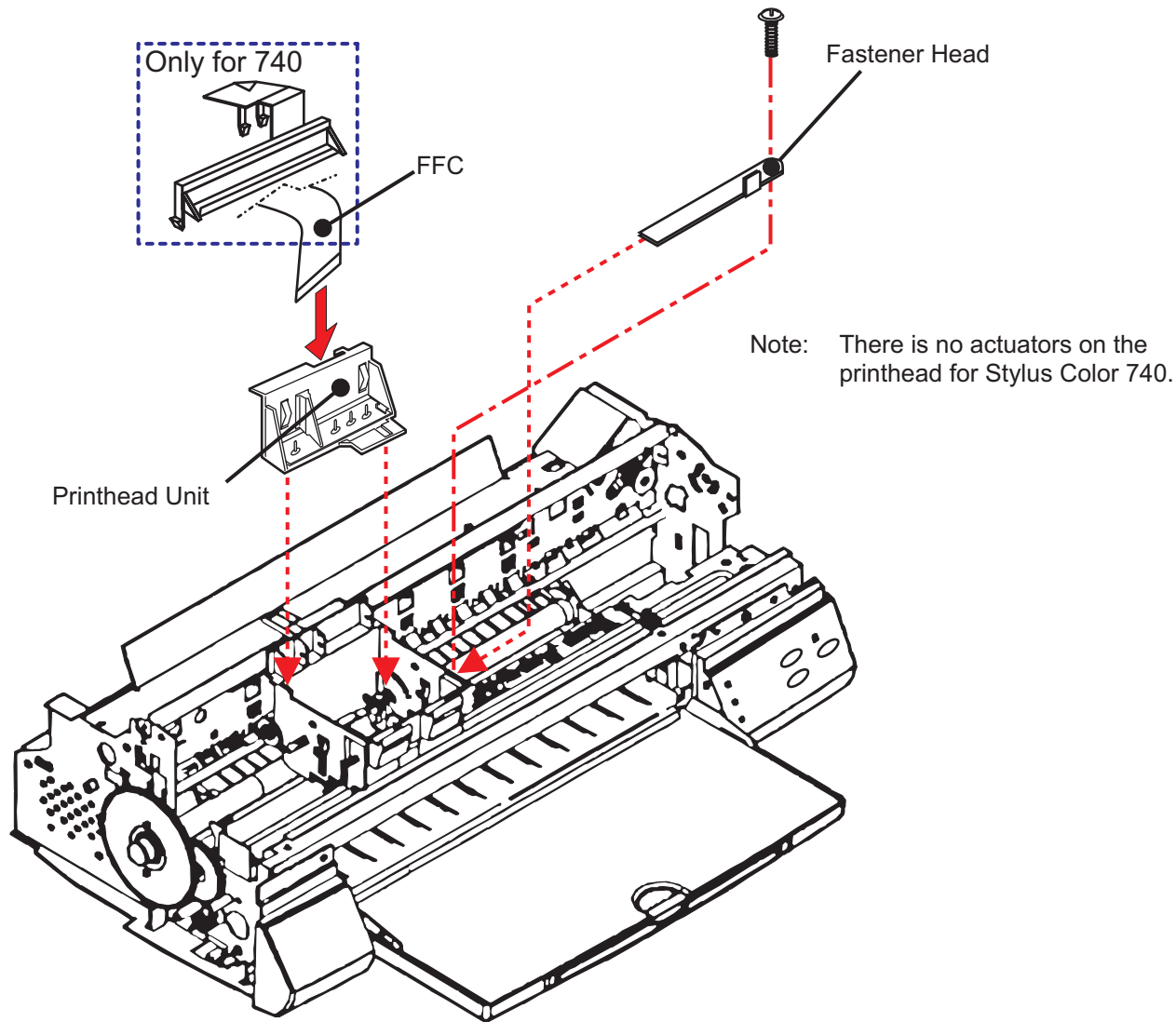

Figure 4-6. Removing the Print Head

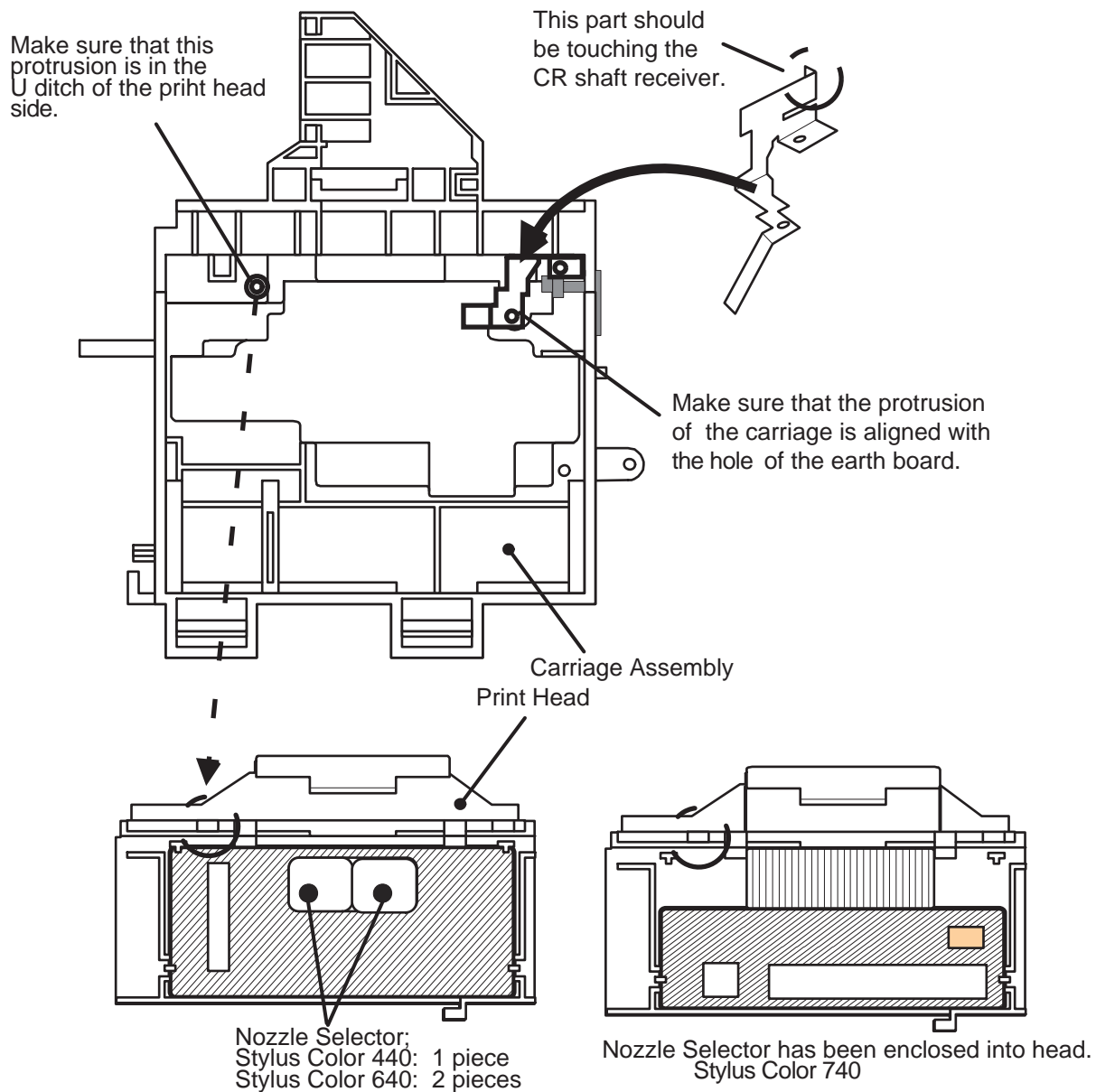

Figure 4-7. Installing the Printhead

#### 4.2.4.2 Removing the Absorber Tray Assembly ;A

1. Remove the housing. (Refer to Section 4.2.1.)
2. Remove the operation panel. (Refer to Section 4.2.3.)
3. Remove one screw (No.4) securing "Absorber tray assembly" located on the right side of the printer mechanism.
4. On the right side of the printer mechanism, release the hook securing the "Absorber tray assembly ;A" to the frame and remove it, pulling it downward.



**When installing the absorber tray assembly ;A, make sure to fix it with the spacer tray in the left side of the printer mechanism.**

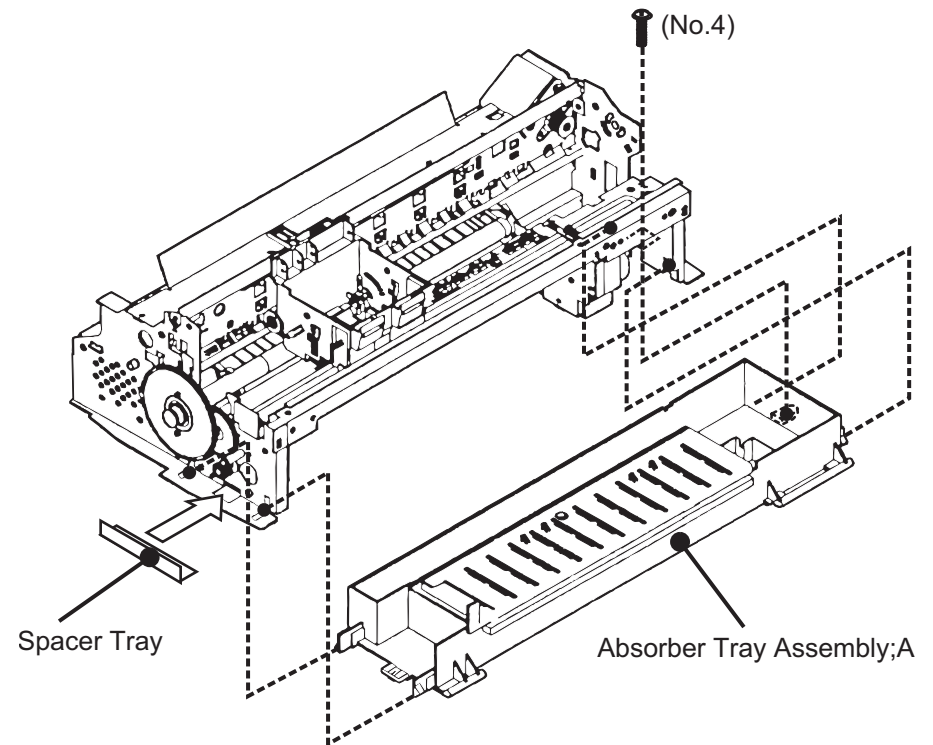

**Figure 4-8. Removing the Absorber Tray Assembly ;A**



#### 4.2.4.3 Removing the Pump Assembly and Cap Assembly

1. Remove the housing. (Refer to Section 4.2.1.)
2. Remove the operation panel. (Refer to Section 4.2.3.)
3. Remove the absorber tray assembly ;A. (Refer to Section 4.2.4.2.)
4. Loosen two screws located on the edge of the paper eject frame assembly and float release the joints for the paper eject assembly and the side frames.
5. Raise the printer mechanism toward ASF side so that you can see the bottom of the printer mechanism.
6. On the right side of frame, remove the hook holding the cap assembly and release two protrusions attached to the frame, lifting up the right side of cap assembly, then take it out towards the bottom of the printer mechanism. Note that the cap assembly is still connected to the pump assembly by the ink tube at this point. (Refer to figures on the next page.)
7. Remove two screws (No.5) securing the pump assembly to the frame. (Refer to the figures on the next page.)
8. Release a hook securing the pump assembly to the frame and remove the pump assembly, moving it toward the right. (Refer to figures on the next page.)

See the following pages for the figures below:

Figure 4-9, "Removing the Cap and Pump Assemblies"

Figure 4-10, "Component of Pump Assembly"



- **Do not damage the rubber part (black square) of the cap installed in the cap assembly. (If it gets damaged, it will not be able to adhere closely to the surface of the print head, and may cause a malfunction in operation.**
- **When you replacing the cleaner head built in the pump assembly, be careful of the following points.**
  - Do not touch the cleaner head with your bare hands. Use gloves or tweezers.
  - Do not let oil or grease touch the head cleaner.
  - When installing the cleaner head, set the rubber side (black side) toward the right side of the frame.
- **When installing the pump assembly, do not tighten the screw more than necessary torque.**



- **Since the spring is included among the gears in the pump assembly, be careful that the parts do not pop out during disassembly and assembly.**
- **When assembling the printer, be careful not to crush nor leave any stress on the ink tube connecting the pump assembly and the cap assembly.**
- **After installing the pump assembly, make sure that the cleaner parts move back and forth by rotating the gear 67.2.**

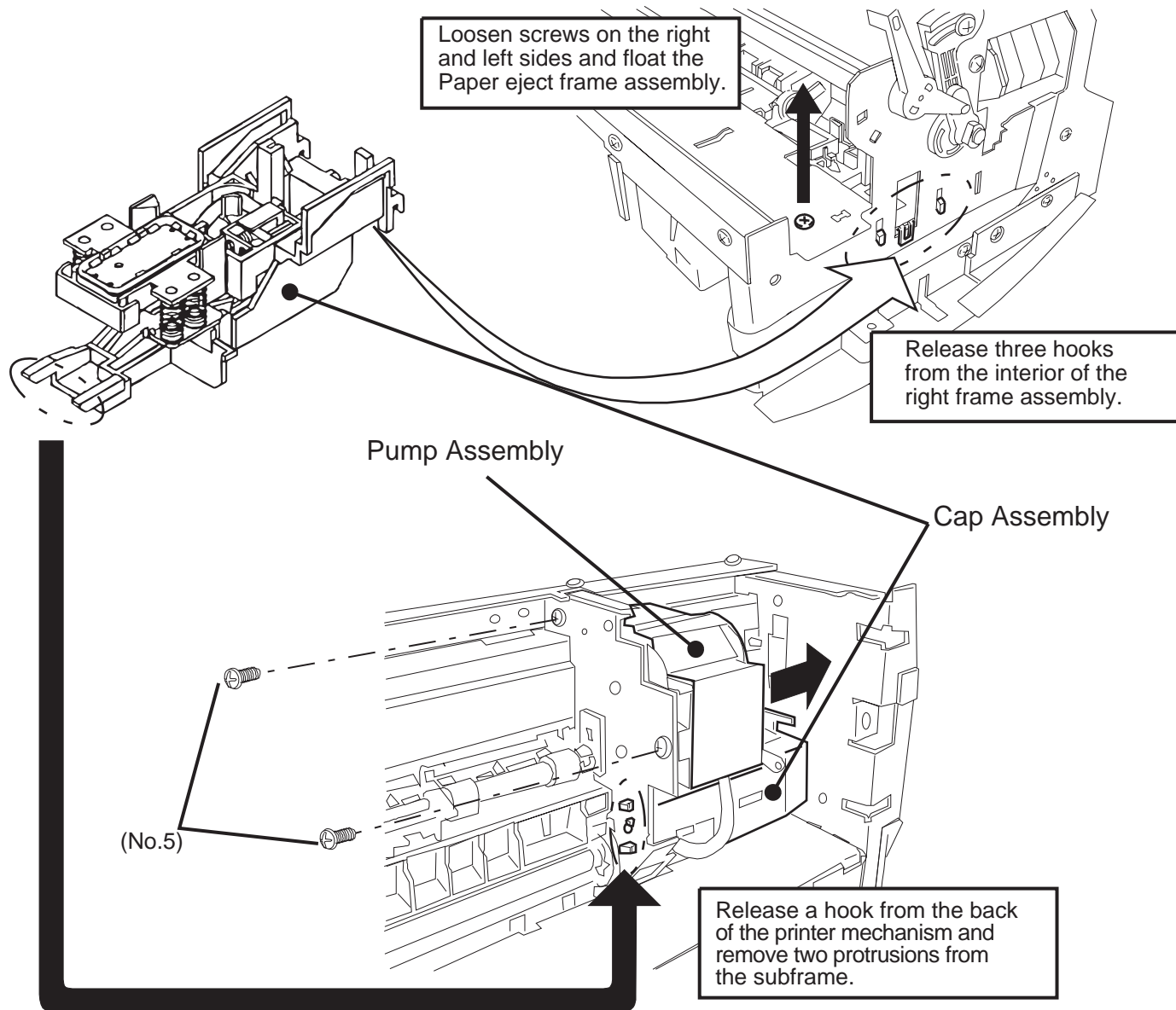
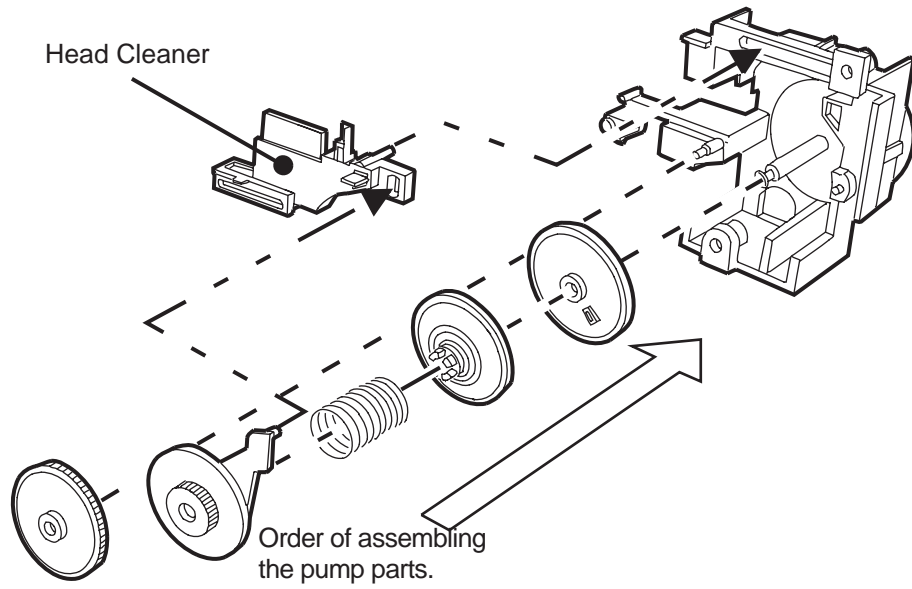

Figure 4-9. Removing the Cap and Pump Assemblies



**Figure 4-10. Component of Pump Assembly**

### 4.2.4.4 Removing the CR Motor Assembly

1. Remove the housing. (Refer to Section 4.2.1)
2. Rotate the gear 67.2 toward you and release the carriage lock mechanism, then move the carriage to the center.
3. Loosen the timing belt by pushing the driven pulley holder and remove the timing belt from the pulley on the CR motor.
4. Remove two screws(No.1) and remove the CR motor assembly.



**After installing the CR motor assembly, make sure that two protrusions on the motor bracket are aligned with the location holes in the frame. (Refer to Figure 4-12.)**

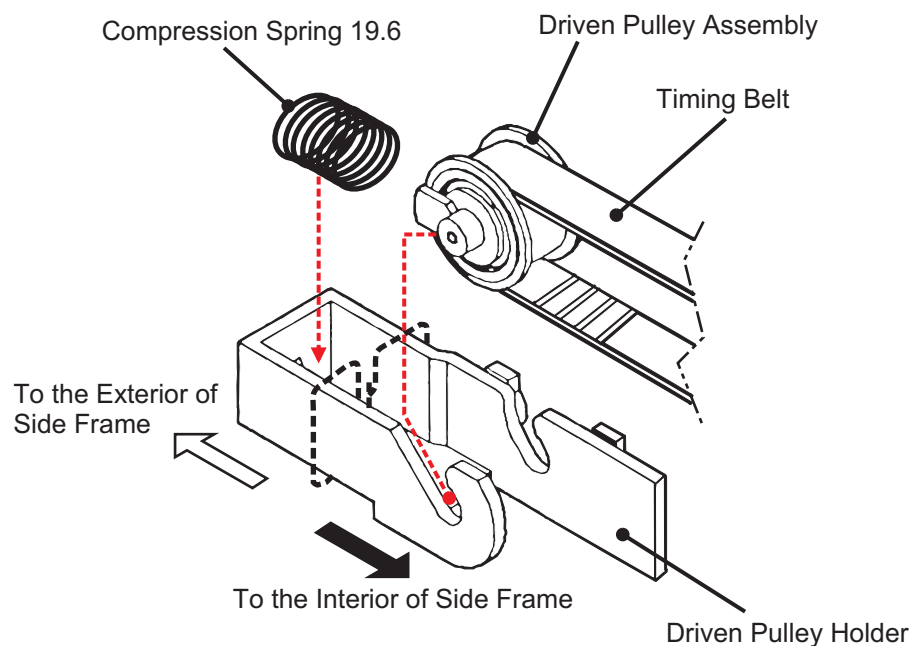

**Figure 4-11. Removing the Timing Belt**

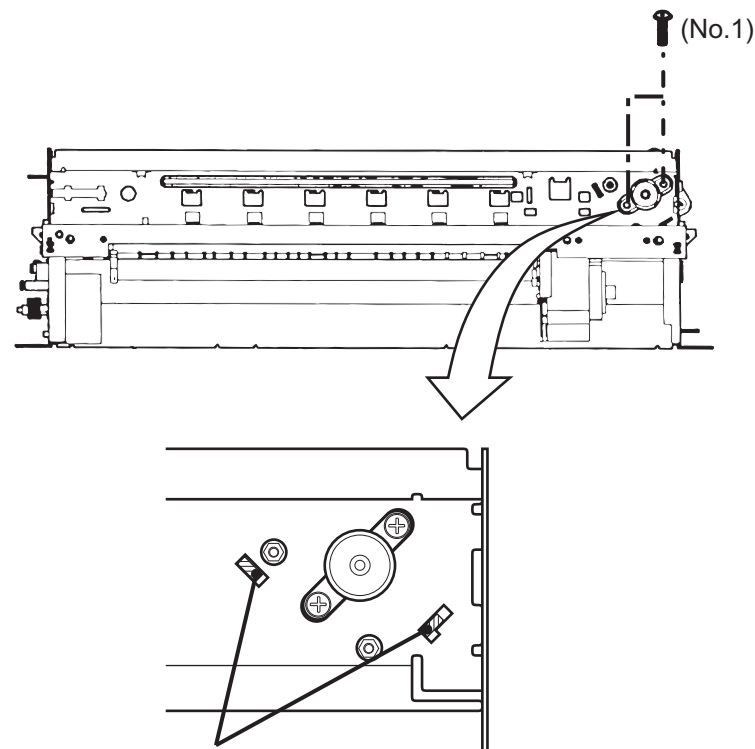

Make sure that protrusions of CR frame are in the holes of the frame when installing the CR motor assembly.

**Figure 4-12. Removing and Installing the CR Motor Assembly**

### 4.2.4.5 Removing the PF Motor Assembly

[For Stylus Color 740]

1. Remove the housing. (Refer to Section 4.2.1.)
2. Remove the absorber tray assembly ;A. (Refer to Section 4.2.4.2.)
3. Remove the following gears located on the left side of the printer mechanism.
  - Gear 67.2 (Remove the ring with tweezers or a (-) driver. After the ring is removed, if you try to remove the gear 67.2 by holding its edge, the gear may break. So, try to remove it while holding the whole gear, slightly pulling it toward you.)
  - Combination gear 8.8,21.6
  - Combination gear 8,14.4
  - Gear 36
4. Remove 2 hexagon nuts and remove the PF motor assembly.



- **When disassembling the PF motor assembly, pull the motor assembly out of the frame a little bit and remove it, sliding it into a larger hole in the frame. (See Figure 4-13.)**
- **Be careful of the direction of the wires from the PF motor assembly.**
- **Do not damage or mar the grooves in the gears during the disassembly and assembly.**

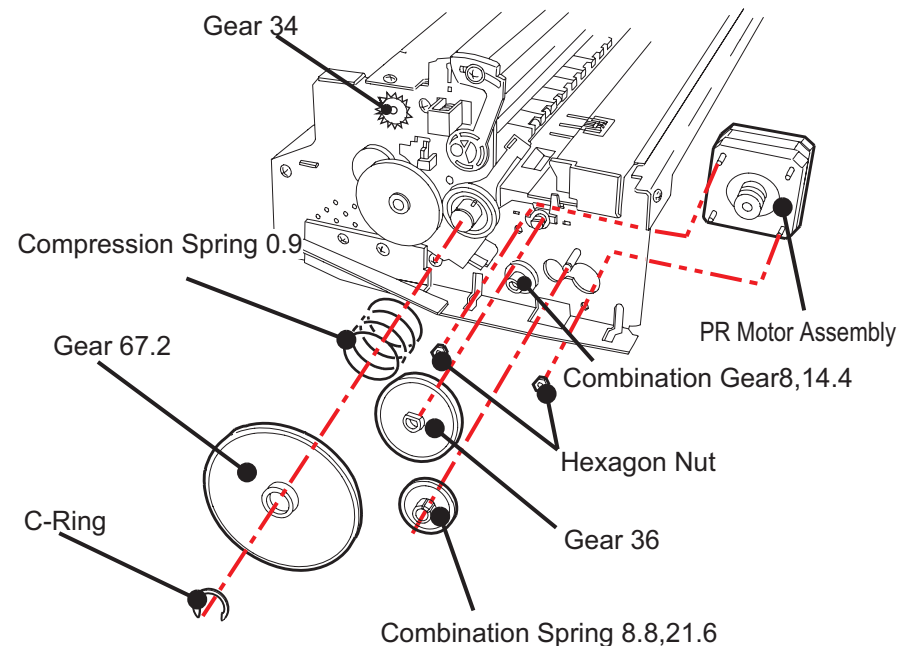

**Figure 4-13.**  
Removing the PF Motor Assembly for Stylus Color 740

**[For Stylus Color 440, 640]**

1. Remove the housing. (Refer to Section 4.2.1.)
2. Remove the absorber tray assembly ;A. (Refer to Section 4.2.4.2.)
3. Remove the 2 screws securing the PF motor assembly. to the frame.



- When disassembling the PF motor assembly, pull the motor assembly out of the frame a little bit and remove it, sliding it into a larger hole in the frame. (Refer to Figure 4-14.)
- Be careful of the direction of the wires from the PF motor assembly.
- Do not damage or mar the grooves in the gears during the disassembly and assembly.

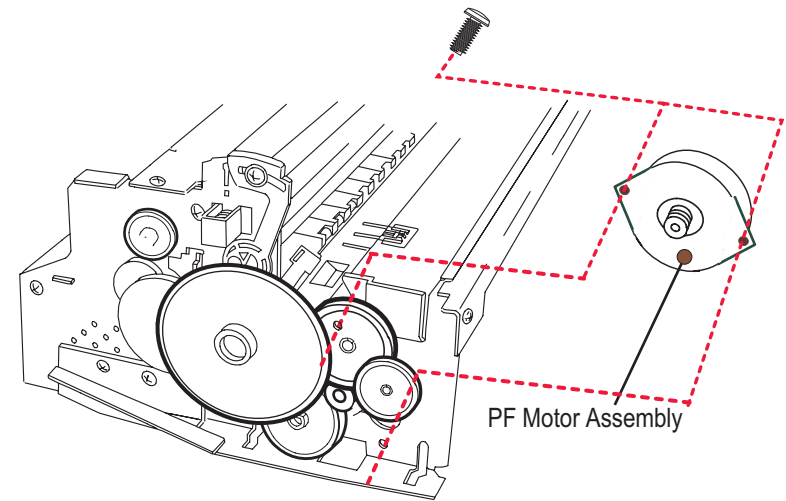

**Figure 4-14. Removing the PF Motor Assembly  
(Stylus Color 440, 640)**

#### 4.2.4.6 Removing the ASF Assembly

1. Remove the housing. (Refer to Section 4.2.1.)
2. Release the fixed hook from the inside of the printer mechanism and remove the gear 34 from the roller shaft in the ASF assembly.
3. Remove the cables from the cable hook on the printer mechanism and the hook on the ASF assembly.
4. After removing 2 screws (one No.7 screw and one CR shaft installation screw), remove the ASF assembly, releasing the protrusion on the left side of the ASF assembly from the hole in the frame.



- When installing the ASF assembly, make sure that the frame and ASF assembly are attached each other without any space between them.
- Screws for ASF assembly should be used at the following positions. (Looking from the back of printer)
  - Right: CR shaft installation screw
  - Left: Screw No.7 (+Bind, S- tight, Sems R2; with a plain washer)

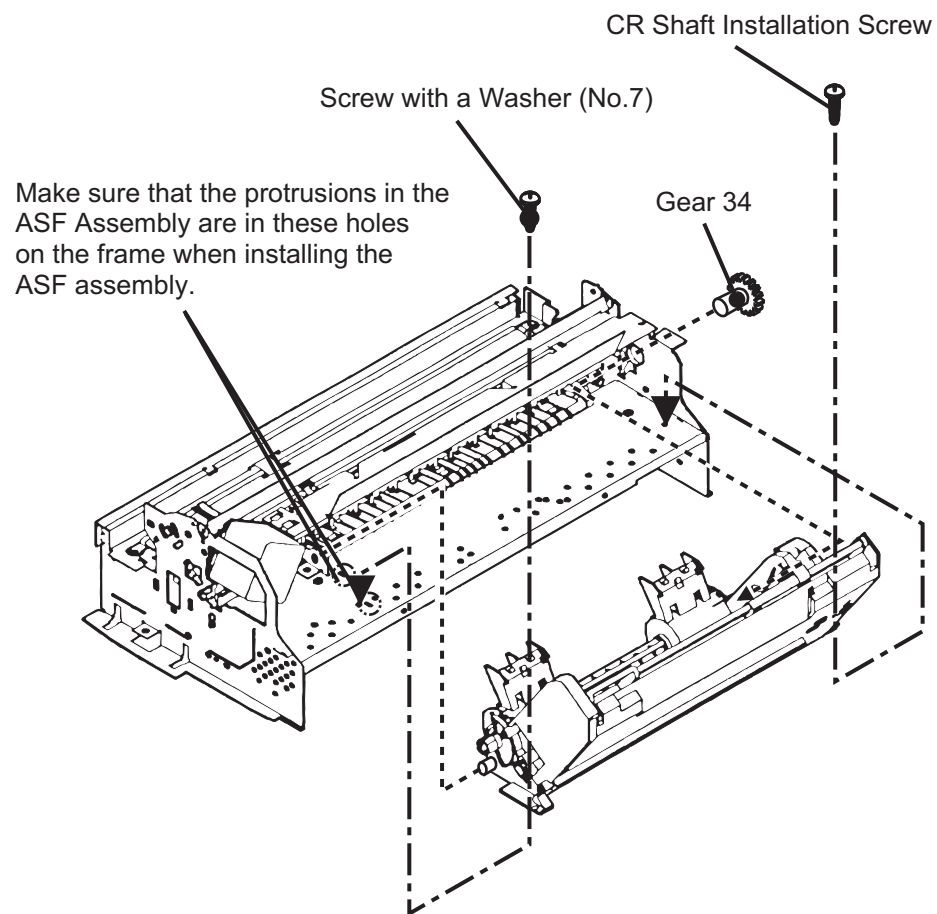

Figure 4-15. Removing the ASF Assembly

#### 4.2.4.6.1 Removing the Paper Feed Roller Assembly

1. Remove the ASF assembly. (Refer to Section 4.2.4.6.)
2. Remove the brake lever, releasing one leg of the torsion spring 41.2 from the hook of the ASF frame.
3. Remove the fixing shaft bushing from the right side of the LD roller shaft and the release hopper lever.
4. Move the left paper feed assembly to the center and remove the cam fixing bushing (white plastic) attached to the left side of LD roller shaft.
5. Push the LD roller shaft to the left and remove the left shaft fixing bushing after releasing its hook.
6. Remove the right and left sides of the hopper assembly from the protrusions on the ASF frame.
7. Lift up the right side of paper feed roller assembly a little, move the LD roller shaft to the right and remove it from the left side of the ASF frame.
8. Holding the hopper assembly by hand, remove the cam part of hopper assembly from the right holes of ASF frame.

The steps by here should remove the right and left LD roller assemblies and the hopper assembly.

See the following page for Figure 4-16, “Disassembly of ASF Assembly”.



- During disassembly and assembly of the hopper assembly, do not let the grease on the cam parts touch other parts. Wipe off any grease smeared on other parts.
- Be careful of the direction of the hopper lever release when installing it.
- Make sure that the right and left fixing bushings are installed steadily and do not slip off.
- During assembly, attach the cam fixing bushing after installing the LD roller shaft to the ASF frame.
- When installing the right and left paper feed roller assemblies to the LD roller shaft, the black paper feed roller assembly goes on the right side and the one in the standard EPSON color goes on the left of the shaft.



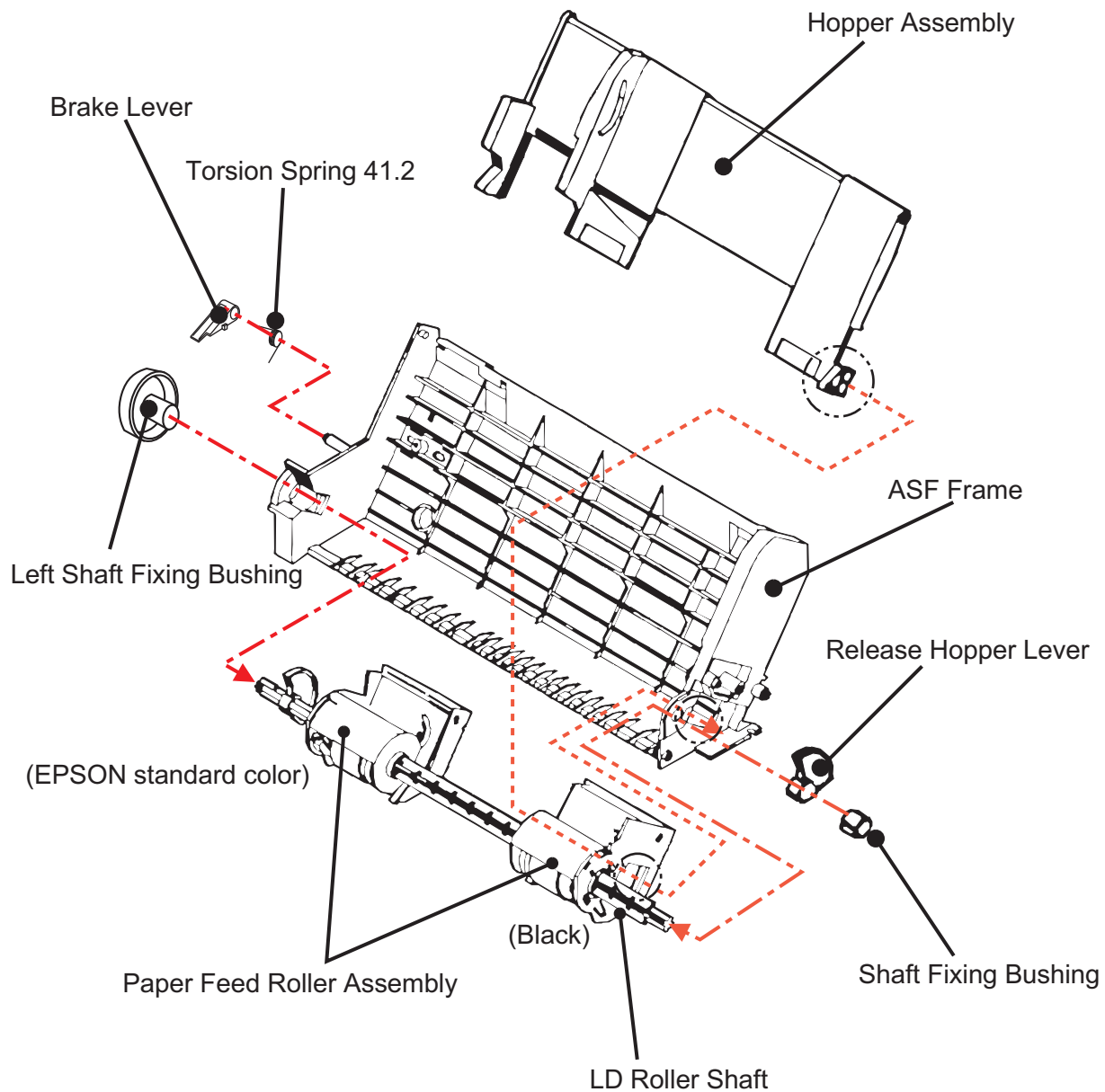

Figure 4-16. Disassembly of ASF Assembly

#### 4.2.4.6.2 Removing the Right and Left LD Roller Assembly

1. Disassemble the ASF assembly and remove the paper feed roller assembly and hopper assembly from the ASF assembly. (Refer to Section 4.2.4.6.)
2. Take out the right and left compression springs 1.66 from the back of the hopper assembly.
3. Pull out the cam part of the hopper assembly from the hole located on the frame of the right LD roller assembly,
4. Pull out the LD roller shaft. The paper feed roller assembly and hopper assembly should be disconnected by now.
5. Release the hook of LD roller assembly at the shaft hole of the paper feed roller assembly. Also, release the fixed hook of the cover roller LD and remove the LD roller assembly.



- **When installing the LD roller assembly, make sure that the hooks are hung on the paper feed assembly.**
- **During assembly, when setting the compression spring 1.66 to the spring installation position in the paper feed assembly, hang the spring on the hook temporarily. Also, do not forget to release the hooks of these springs from the holes located on the back of paper feed assembly by rotating the spring. (Refer to the figure below.)**

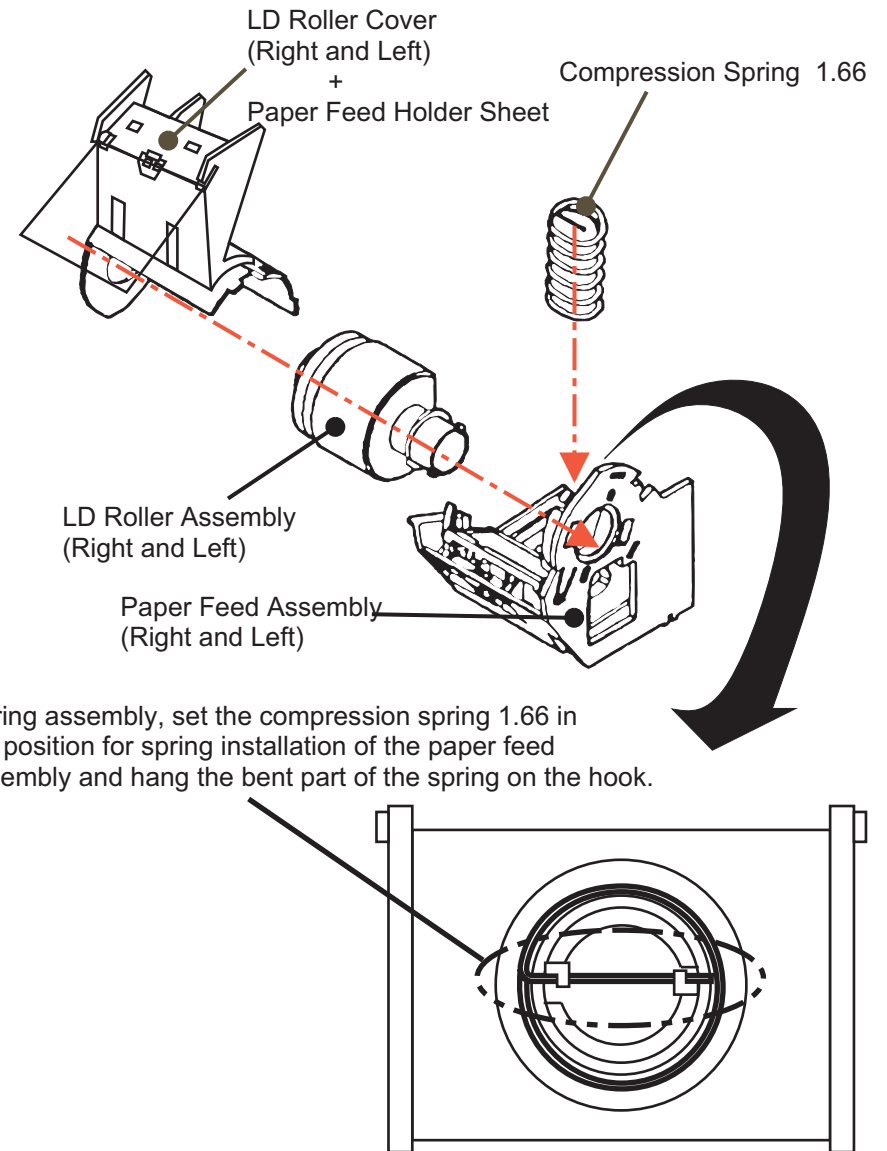

Figure 4-17. Disassembly of Paper Feed Roller Assembly

#### 4.2.4.7 Removing the Carriage Assembly

1. Remove the housing. (Refer to Section 4.2.1)
2. Loosen the timing belt by pushing the driven pulley holder and remove the timing belt from the pulley of the CR motor side.
3. Take the compression spring 19.6 out of the driven pulley holder.
4. Remove the driven pulley assembly from the driven pulley holder with the timing belt. Slide the driven pulley holder and remove it from the frame.
5. Remove the torsion spring hanging on the frame and PG lever. Release the fixed hook of the PG lever and remove the lever.
6. Release the fixed hook of the PG lever support and remove the PG lever support and washer from the edge of the CR guide shaft. (Refer to the figure next page.)
7. Remove one screw(No.7) and rotate the right parallelism adjustment bushing so that it fits in the notch of the frame, and remove it.
8. Remove CR assembly with the CR guide shaft.



- When disassembling the right parallelism adjustment bushing, mark present location where the bushing is fixed on the frame so that you can omit gap adjustment after assembly.
- When installing the washer, pay attention to its direction.(Convex side should face the right parallelism adjustment bushing side.) Refer to the figure below.
- When installing the PG lever, refer to the figure below.

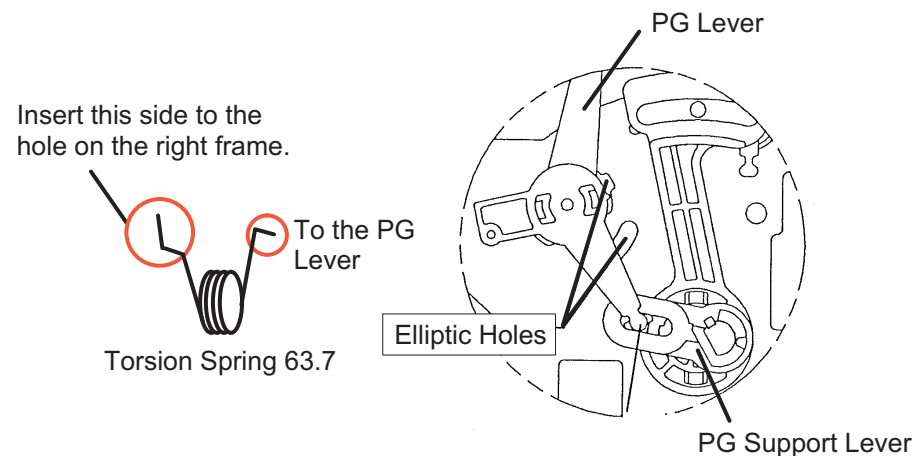
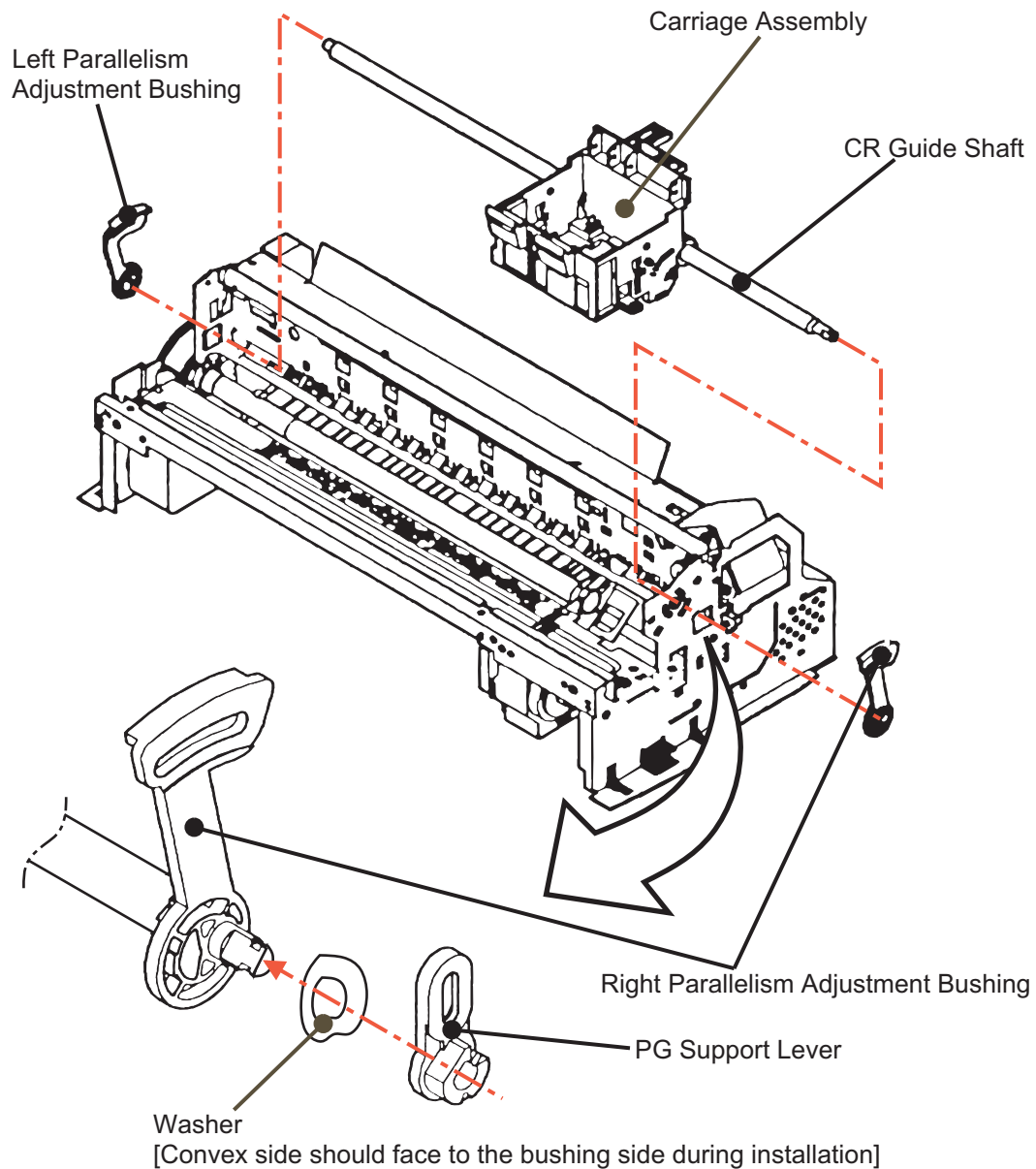

Figure 4-18. Installing the PG Lever



**Figure 4-19. Removing the Carriage Assembly**

#### 4.2.4.8 Removing the PF Roller Assembly

1. Remove the housing.(Refer to Section 4.2.1.)
2. Remove the carriage assembly.(Refer to Section 4.2.4.7.)
3. Remove three screws(No.1) on the printer mechanism and disassemble the cable guide board.
4. Remove six upper paper guide assemblies, releasing their springs from the hooks in the frame.
5. Remove the front paper guide ;B, releasing the hooks. (Refer to next page.)
6. Remove the paper eject roller assembly, releasing the fixed locks located on the right and left edges of the shaft.
7. Release the fixed hook located on the left side of the PF roller assembly shaft and rotate it so that the protrusion on the shaft (white) and hole for receiving the shaft in the frame align.
8. Slide the PF roller assembly to the right and pull it out.



- During disassembly and assembly of the upper paper guide assemblies, since one of the upper paper guide assemblies to be installed on the right side overlaps with the PE detector lever, pay attention not to damage the lever.
- Be careful not to damage the hook during disassembly and assembly of the front paper guide ;B.
- Be careful not to scratch the PF roller assembly during disassembly and assembly, since its surface is specially coated to improve paper feeding. (black part)
- Be careful not to damage the combination gears.

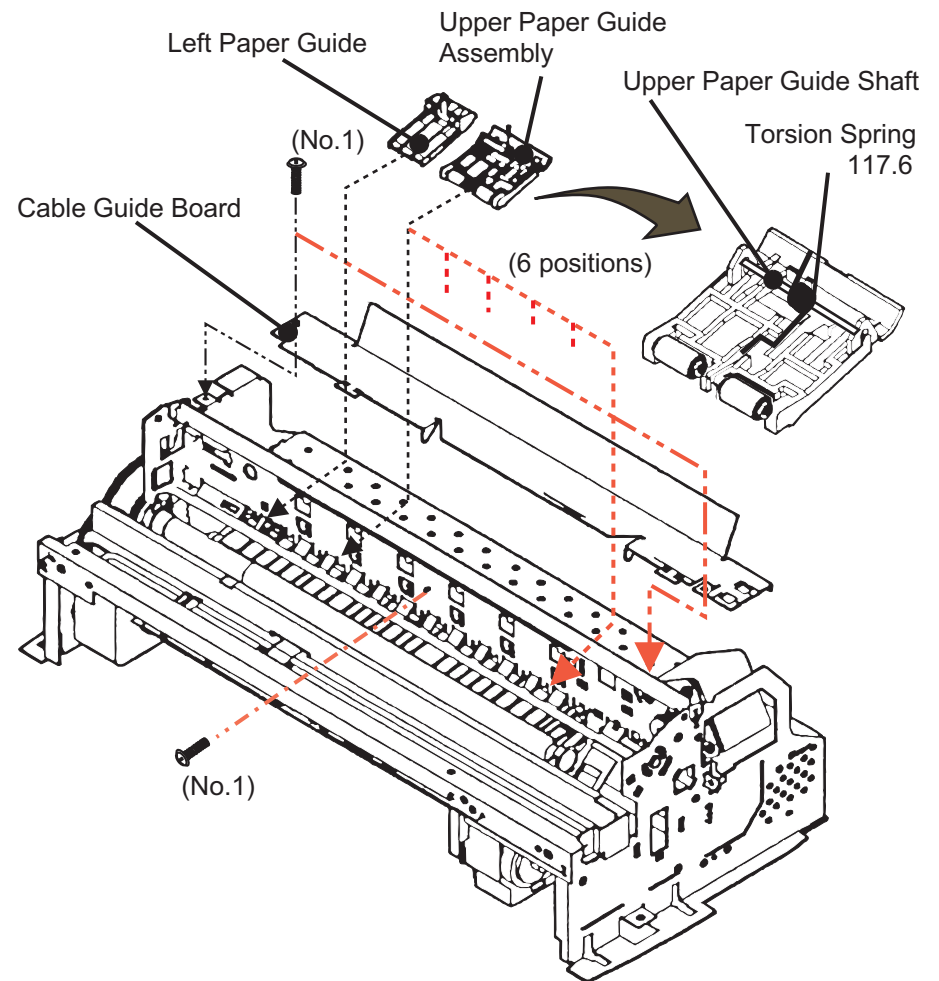

Figure 4-20. Removing the Paper Guide Assembly

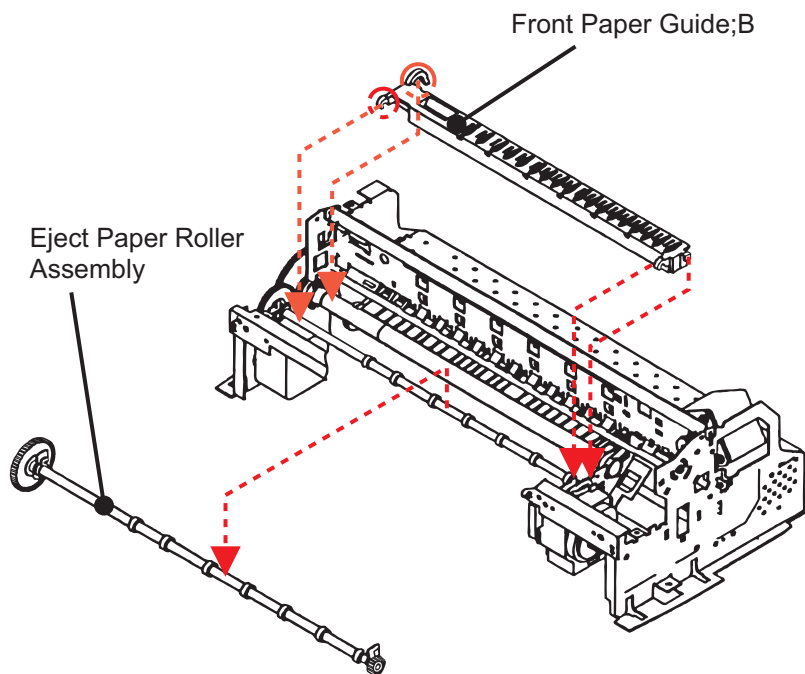

Figure 4-21. Removing the Paper Eject Roller Assembly

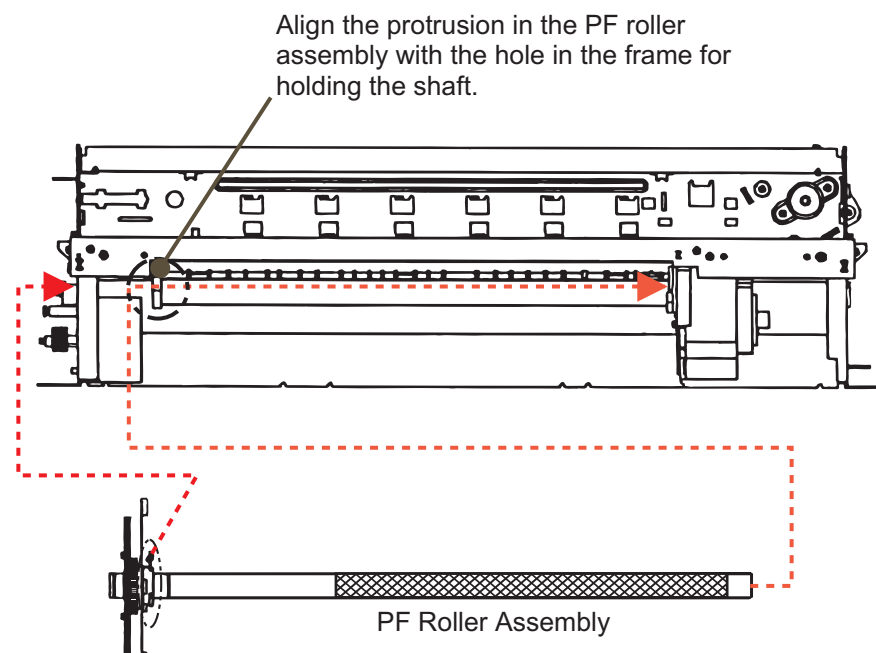

Figure 4-22. Removing the PF Roller Assembly

#### 4.2.4.9 Removing the PE Paper Detector Assembly

1. Remove the housing. (Refer to Section 4.2.1.)
2. Release two fixed hooks securing the PE detector assembly from the back of the frame and remove the PE detector assembly, sliding it upward.



During assembly, make sure that the tip (sensor part) of the detector lever is in the hole of paper guide assembly.

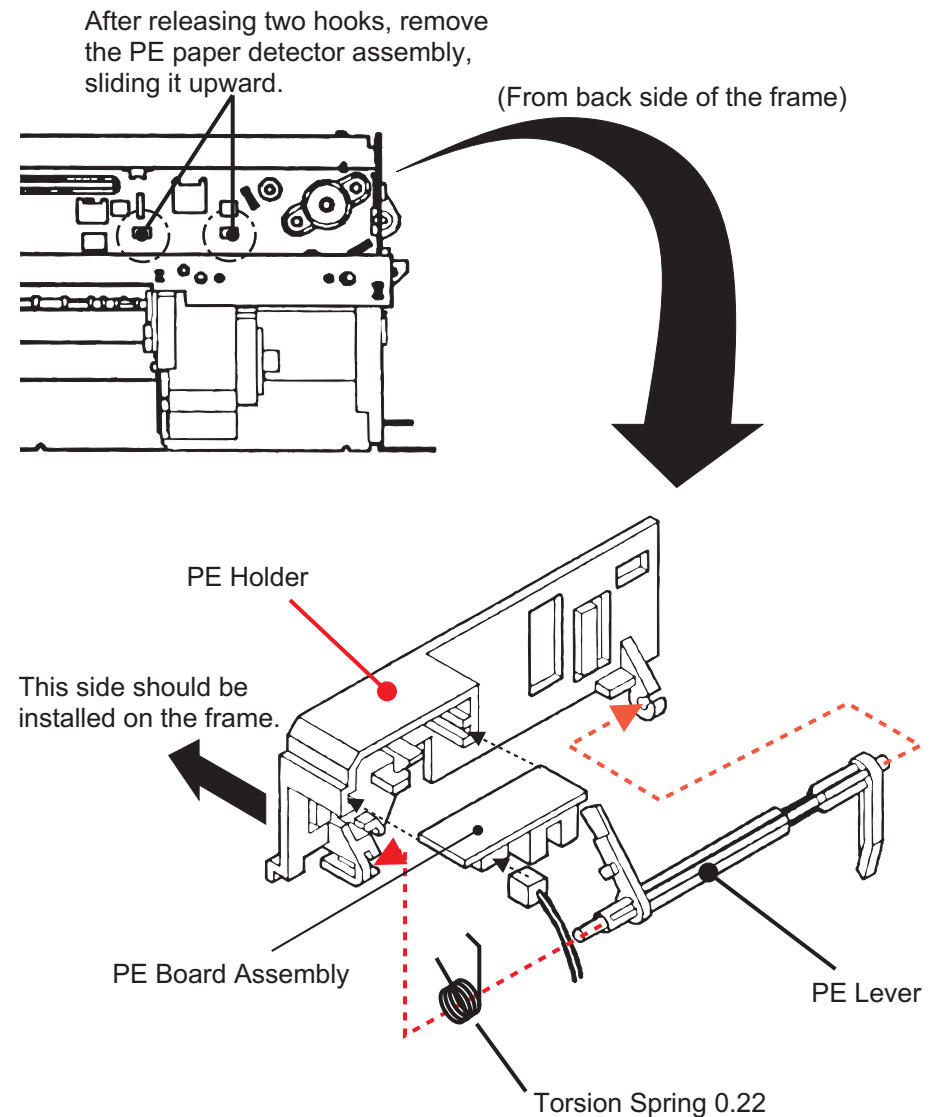

Figure 4-23. Removing the PE Detector Assembly

#### 4.2.4.10 Removing the HP Detector

1. Remove the housing. (Refer to Section 4.2.1.)
2. Remove the cable from the HP detector and take it out after releasing the fixed hook.

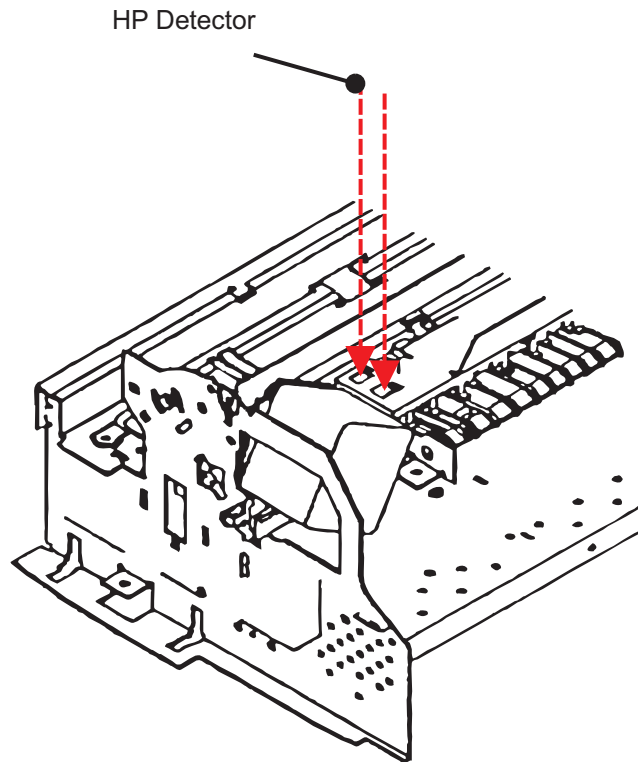

Figure 4-24. Removing the HP Detector



**CHAPTER**

**5**

**ADJUSTMENT**

## 5.1 Overview

This chapter describes adjustments required when the printer is disassembled and assembled after repair.

### 5.1.1 Required Adjustments

Stylus Color 440/640/740 require the following adjustments. (Refer to Table 5-1) Perform any necessary adjustment referring to the figures and procedures described throughout this chapter.

**Table 5-1 Adjustment Required**

No.	Adjustment Item	Conditions
1	Parallelism Adjustment	<ul style="list-style-type: none"> <li>When you replace or remove the Carriage guide shaft.</li> <li>When you move the parallelism adjustment bushing.</li> </ul>
2	Initial Ink Charge	<ul style="list-style-type: none"> <li>When you replace or remove the printhead.</li> </ul>
3	Head Voltage ID Input	<ul style="list-style-type: none"> <li>When you replace the printhead.</li> <li>When you replace the main board.</li> </ul> <p><b>Note)</b> The values stored in this address are not erased by EEPROM reset operation.</p>
4	Printing Head Angle Adjustment	<ul style="list-style-type: none"> <li>When you replace or remove the printhead.</li> <li>When you move the printhead angle adjusting lever.</li> </ul>
5	Bi-D Adjustment	<ul style="list-style-type: none"> <li>When you replace or remove the printhead.</li> <li>When you replace the main board.</li> <li>When you replace the CR Motor.</li> </ul>

Table below shows the actions taken and required adjustments in the order to be performed.

**Table 5-2 Actions Taken and Adjustment Required**

No.	Content of Operation	Adjustment Procedure
1	Removal of the printhead	<ol style="list-style-type: none"> <li>Perform initial ink charge.</li> <li>Perform printhead angle adjustment.</li> <li>Perform Bi-d Adjustment.</li> </ol>
2	Replacement of the printhead	<ol style="list-style-type: none"> <li>Perform Vh voltage writing operation.</li> <li>Perform initial ink charge.</li> <li>Perform printhead angle adjustment.</li> <li>Perform Bi-d Adjustment.</li> </ol>
3	Replacement of the main board	<ol style="list-style-type: none"> <li>Perform Vh voltage writing operation.</li> <li>Perform Bi-d adjustment.</li> <li>Perform CG TAbLe setting (only for Stylus Color 740)</li> </ol>
4	Replacement or Removal of the Carriage Unit	<ol style="list-style-type: none"> <li>Perform parallel adjustment.</li> <li>Perform printhead angle adjustment.</li> <li>Perform Bi-d adjustment.</li> </ol>
5	Replace of the CR Motor	<ol style="list-style-type: none"> <li>Perform Bi-d adjustment.</li> </ol>
6	Replacement of the Printer Mechanism	<ol style="list-style-type: none"> <li>Perform Head Voltage ID Input.</li> <li>Perform initial ink charge.</li> <li>Perform Bi-d adjustment.</li> </ol>

## 5.1.2 Adjustment Tools Required

Table 5-3 below shows adjustment tools for Stylus Color 440/640/740.

**Table 5-3 Adjustment Tools Required**

No.	Name	Adjustment Item	Contents/Spec.
1	Thickness Gauge	Parallelism Adjustment	1.04 mm
2	Adjustment Program	Each Mechanism Settings	Exclusive Program; SC440.EXE SC640.EXE SC740.EXE



- Never use the bent (curved or tilted) or rusty thickness gauge.
- Erase any dirt, grease or obstacles on the thickness gauge before you use it.

## 5.2 Adjustment

This section explains specific procedures for each adjustment required for Stylus Color 440/640/740.

### 5.2.1 Parallelism Adjustment

When replacing the carriage assembly or removing it during printer mechanism disassembly, perform the parallelism adjustment during assembling and set the standard distance from the surface of the printhead to the paper surface.



- Do not scratch the special coated surface of the PF roller assembly and rib surface of the front paper guide ;B.
- Be careful not to leave any mar or dirt on the surface of the printhead. (Never use a rusty or dirty thickness gauge. Also, do not push the thickness gauge hard against the head.)

#### [Right Parallelism Adjustment]

1. Install the "parallelism adjustment bushing" for right and left frame and set them on the peaking of the upper frame side so that they match with "the standard mark of parallelism adjustment bushing".
2. Set the PG lever front. (Gap is small.)
3. Move the carriage to the center and set the thickness gauge on the fixed position of front paper guide ;B as you can see in the figure 4-1 on the next page
4. Move the carriage to the position that the printhead overlaps the thickness gauge.



- Put the thickness gauge on the flat side of the rib of the front paper guide ;B.
- When you move the carriage, move it, pulling the timing belt with your hand.

5. Move the right parallelism adjustment bushing to the rear until the thickness gauge moves with the carriage when you move the carriage about 20 mm right and left. (Gap will be narrowed.)
6. From this thickness with which the thickness gauge starts moving with the carriage, move the gear of the right parallelism adjustment bushing one notch toward you. (Gap will be widen.)
7. With the PG lever set front (gap is small) and then rear, move the carriage right and left and make sure that the thickness gauge does not move for the both settings.

#### [Left Parallelism Adjustment]

8. Perform Steps 2 to 7 for the left parallelism adjustment bushing.

#### [Checking parallelism]

9. Perform steps 1 to 4 again.
10. Make sure that the thickness gauge does not move right and left along with the carriage when the carriage is moved about 20 mm.
11. Move the right parallelism adjustment bushing one notch to the rear (Gap will be narrowed). Then check that the thickness gauge moves along with the carriage. If the thickness gauge does not move, go back to Step 1 and repeat the adjustment.
12. If the gap is adjusted correctly, move the right parallelism adjustment bushing one notch toward you (Gap will be widen).

[Fixing Parallelism Adjustment Bushing]

13. Fix the right and left parallelism adjustment bushings with screws.  
(No.1 screw for each.)

When completing this adjustment, check the overlap amount of the printhead and head cleaner.

1. Rotate the gear 67.2 and move the head cleaner to the printer rear side.
2. Move the carriage next to the head cleaner and make sure that overlap between the tip of the printhead and cleaner head is more than 0.5 mm.
3. Then, rotate the gear 67.2 and return the head cleaner to the front position.

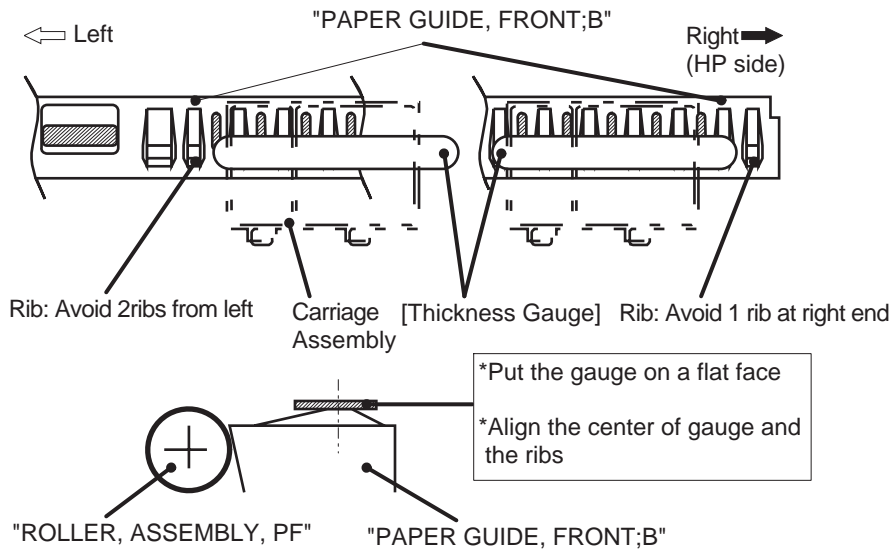

Figure 5-1. Setting of the Gauge at Parallelism Adjustment

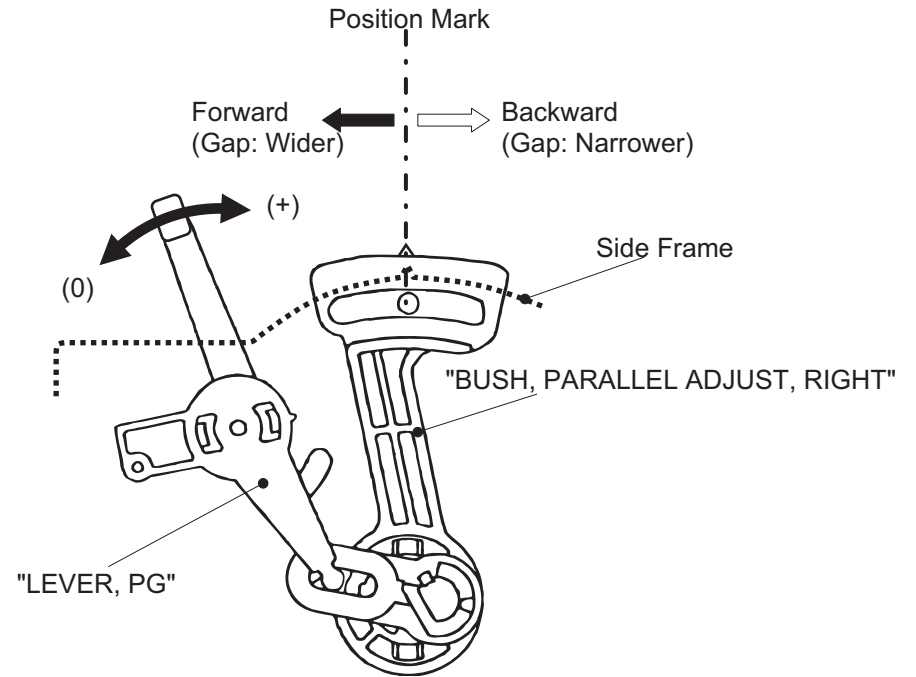

Figure 5-2. Parallelism Adjustment

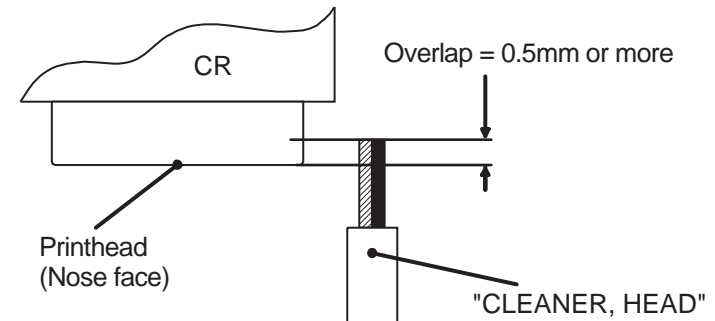

Figure 5-3. Overlap of Head Surface and Cleaner Blade

## 5.2.2 Adjustment by Adjustment Program

In this printer, it is necessary to set the correct information for each printer mechanism in order to maintain consistent printing function and quality, eliminating difference of each printer mechanism's characteristics.

Therefore, in case that the combination of the printer mechanism and main board changes or the printhead is replaced during repair, you must set and save the correct information to the main board, using the exclusive adjustment program.

### 5.2.2.1 About Adjustment Program

The adjustment program (Program name: SC440.EXE, SC640.EXE, SC740.EXE) enables you to set various values correctly to prevent malfunction and fluctuation of printing quality and printing function caused by difference in components and assembly when the printer components are replaced during repair. Basic adjustment procedure by using this program are shown in the right column.

The flowchart below shows the steps to follow before entering the main menu.

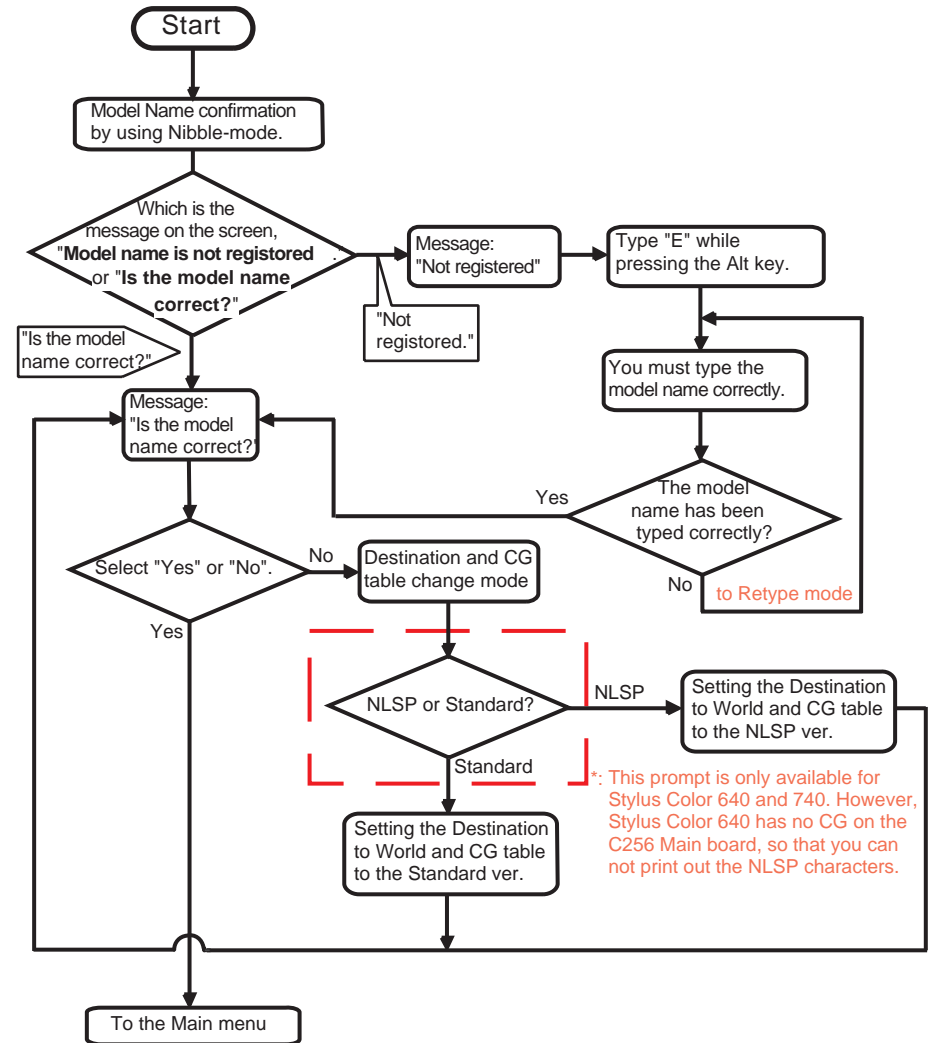

Figure 5-4. Interface Flow of Adjustment Program

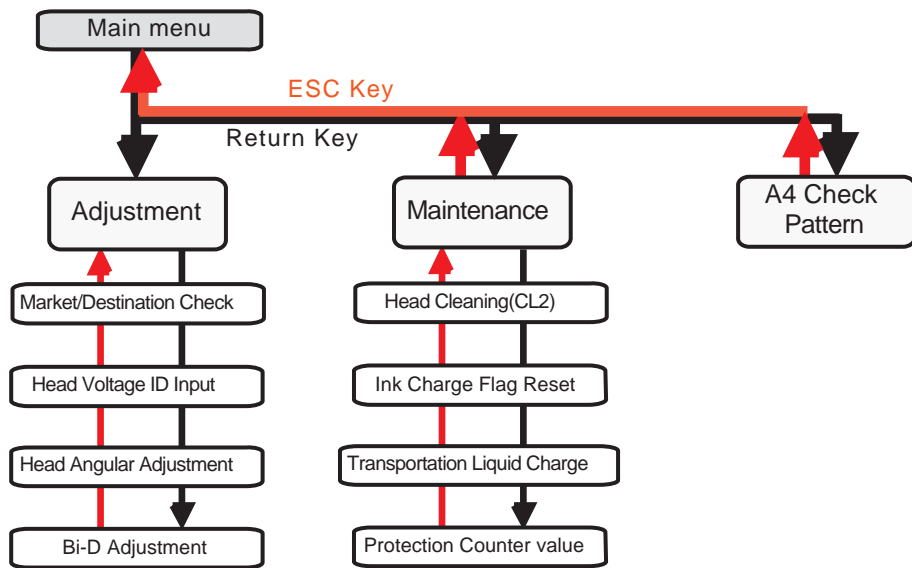

Figure 5-5. Options in the Program and Keys to Use

### 5.2.2.2 Entering the Main menu

Before performing any adjustment, you need to enter the main menu, however, you may have to take the following extra steps before entering the main menu depending on the printer model name and mode name registration status.

- Registering the model name (Section 5.2.2.2.1.)
- Setting the CG (Section 5.2.2.2.2.)

Therefore, read the instructions carefully and take the appropriate steps.

1. Connect the printer and PC and turn on the printer.
2. Insert the disk for the adjustment program to the floppy disk drive. Type SC440, SC640, or SC740 on the DOS or DOS prompt.
3. Type the exclusive program name\* SC440.EXE, SC640.EXE, or SC740.EXE on the DOS prompt.

\* The adjustment program name provided with each printer is shown below.

A(In case of FD):\SC440.EXE for Stylus Color 440  
 A(In case of FD):\SC640.EXE for Stylus Color 640  
 A(In case of FD):\SC740.EXE for Stylus Color 740

4. Following screen appears.

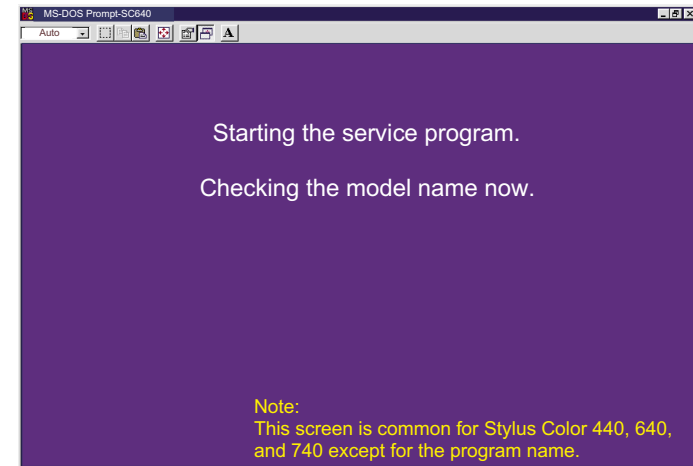

Figure 5-6. Initial Screen (1)

- ➔ If the printer's model name has been registered, go to **Step 5.**  
**[For Stylus Color 740]**  
**If your printer is Stylus Color 740, you must set the correct CG, *NLSP* or *Standard*. Therefore, be sure to read the instructions in the following step carefully to take the proper steps.**
- ➔ If no model name is registered, go to **Section 5.2.2.2.1 / Step 1.**



5. After a few seconds, the model name appears on the screen shown below. Proceed to one of the following steps.

➔ If the printer is Stylus Color 440 or 640, go to **Step 6**.

➔ If the printer is Stylus Color 740, go to **Section 5.2.2.2.2 / Step 1**.

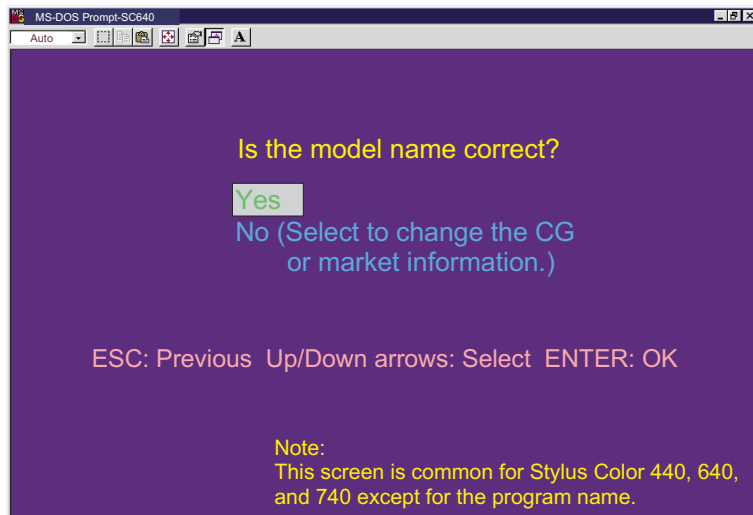

Figure 5-7. Initial Screen (2)



If the screen above does not appear, it means no model name is registered, and you must proceed to **Section 5.2.2.2.1 / Step 1** as the screen automatically advances to the Mode Name Null Condition screen (Figure 5-9).

6. The main menu shown below appears.

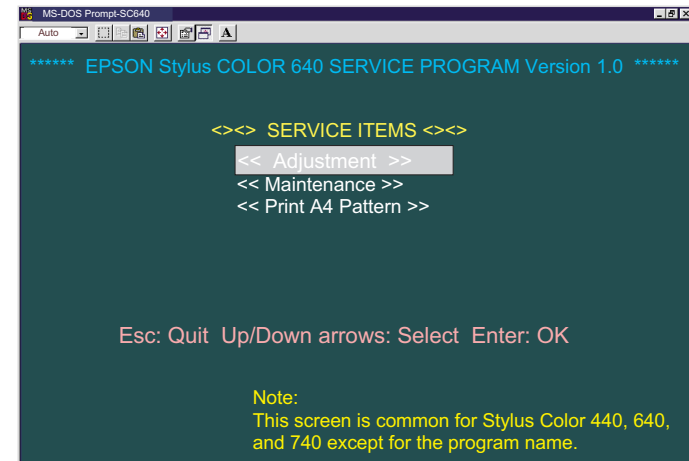

Figure 5-8. Main Menu of the Program

5.2.2.2.1 Registering the printer model name

1. If no model name is registered, the screen shown below appears. Press the **E** key while pressing the **Alt** key, and the program advances to the Model Name Input Screen.

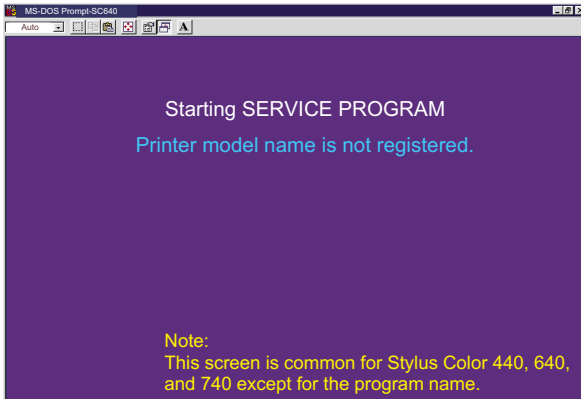

Figure 5-9. Model Name Null Condition

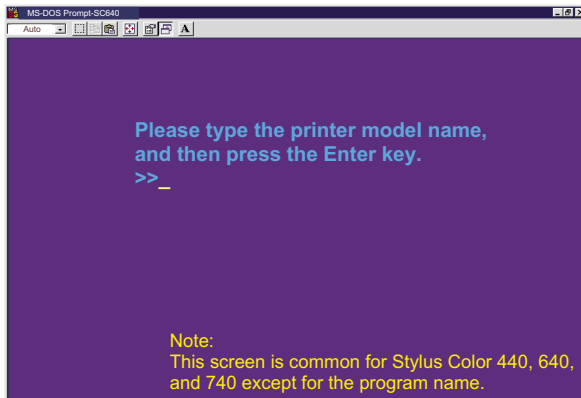

Figure 5-10. Model Name Input Screen

2. Type the correct model name, referring to the box below.

```
Stylus_COLOR_440
Stylus_COLOR_640
Stylus_COLOR_740
```



- "-" means a space.
- Be sure to type the model name in exactly the same way as shown above, paying attention to the text formats, uppercase or lowercase.
- If you mistype the model name, the program will automatically return to the model name input screen (Figure 5-10).

- 3.



**For Stylus Color 740:**  
If the printer is Stylus Color 740, you must set the correct CG, **NLSP** or **Standard**. Therefore, be sure to read the instructions below carefully to take the proper steps.

After a few seconds, the model name appears on the Initial Screen (2) (Figure 5-7). Proceed to one of the following steps.

- ➔ If the printer is Stylus Color 440/640, return to **Section 5.2.2.2 / Step 6**.
- ➔ If the printer is Stylus Color 740, proceed to **Section 5.2.2.2.2 / Step 1**.

### 5.2.2.2.2 Setting the CG (Destination information) (For Stylus Color 740 only)

Since there are two models for Stylus Color 740, the standard model and NLSP model, you are required to set the correct CG according to the model by following the steps described in this section.

#### 1. (For Stylus Color 740 only)

Select **"No"** on the Initial Screen (2) (Figure 5-7), and the screen below appears.

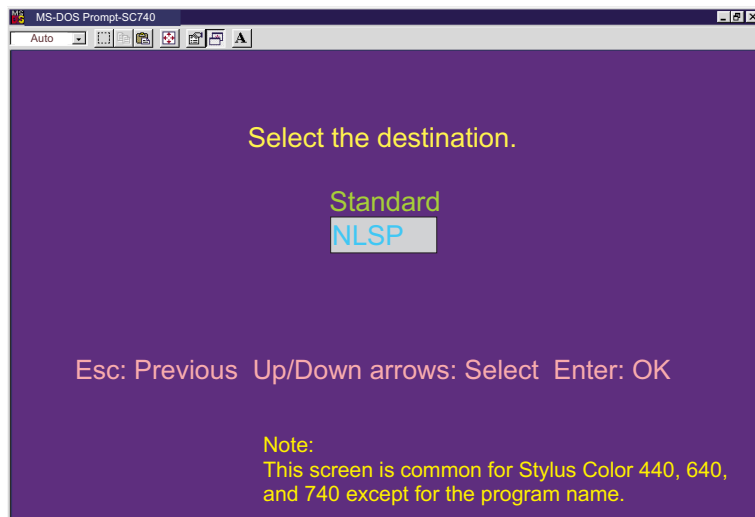

Figure 5-11. Destination Setting Screen for Stylus Color 740

#### 2. (For Stylus Color 740 only)

Perform one of the followings:

- If your Stylus Color 740 supports the NLSP characters, select **NLSP** by using the reverse carols. Be sure to perform this operation because a spare C257 Main board has the CG set to **Standard** at factory.
- If your Stylus Color 740 does not support the NLSP characters, select **Standard**.

The program automatically returns to the Initial Screen (2) (Figure 5-7) after a few seconds.

➔ The CG value has been correctly set. Return to **Section 5.2.2.2 / Step 6** to enter the main menu.



**Do not select the NLSP if your Stylus Color 740 does not support the NLSP characters. You can distinguish the NLSP model from Standard model by referring to the following point on the C257 Main board;**

- **Standard:** There is no IC6 on C257 Main board.
- **NLSP:** There is IC6 on C257 Main board.

### 5.2.2.3 Initial Ink Charge Operation

There is no ink charged in the ink path of a spare printhead and printer mechanism. Therefore, after you replaced any of the following units, perform initial ink charge and return the printer after making sure that ink is ejected correctly from the printhead.

- After replacing the printer mechanism
- After replacing or removing the printhead

1. Enter the main menu. (Refer to Section 5.2.2.2.)
2. In the main menu (Figure 5-7), select **Maintenance** using the Up/Down arrow key, and the Maintenance Menu below appears.

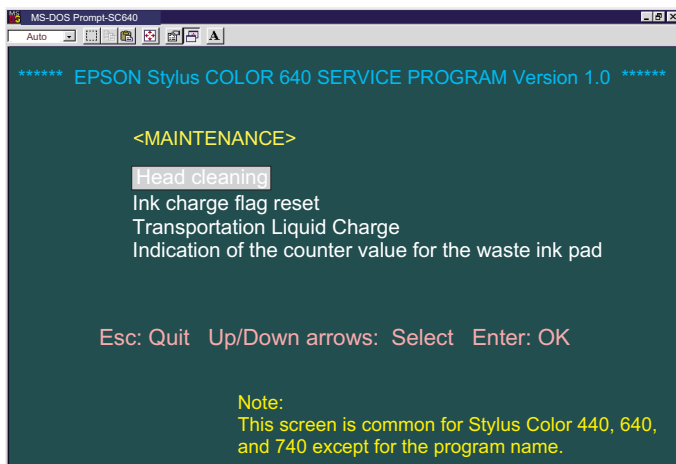

Figure 5-12. Maintenance Menu of the Program

3. By using the Up/Down arrow key, select **Ink Charge Flag Reset** in the maintenance menu (Figure 5-12), and the Initial Ink Charge Menu below appears.

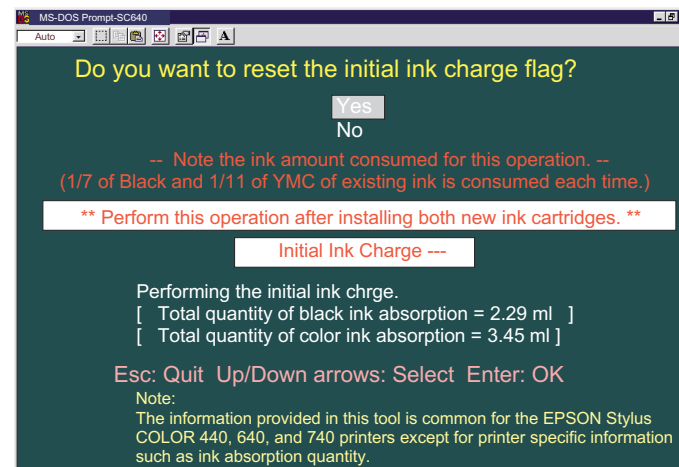

Figure 5-13. Initial Ink Charge Menu



**Before you set the initial ink charge flag, replace the installed cartridges with new ones, because the ink amount used for the initial ink charge operation is so large.**

4. Press the Enter key while the reverse cursor is indicating **Yes**.
5. Turn off the printer and back on after 10 seconds, and the printer automatically enters the initial ink charge sequence. (It takes 90 seconds for this operation to complete the whole sequence.)

### 5.2.2.4 Head Cleaning Operation

Different from the previous models, Stylus Color 440, 640, and 740 have no dummy cleaning sequence called CL3, which was performed to prevent ink from being unnecessarily consumed when cleaning was repeated without any printout. However, Stylus Color 440/640/740 is alternatively equipped with the strongest cleaning sequence CL2 contained in this adjustment program. With this sequence, you can forcibly solve the clogged nozzle problem caused by viscous ink.



**If you can not recover the clogged nozzles despite you performed CL2 operation, enter the Initial ink charge sequence by referring to Section 5.2.2.3.**

1. Enter the main menu. (Refer to Section 5.2.2.2.)
2. Apply the Maintenance menu (Figure 5-12).
3. By using the Up/Down arrow key, select **Head cleaning**, and the following screen appears.

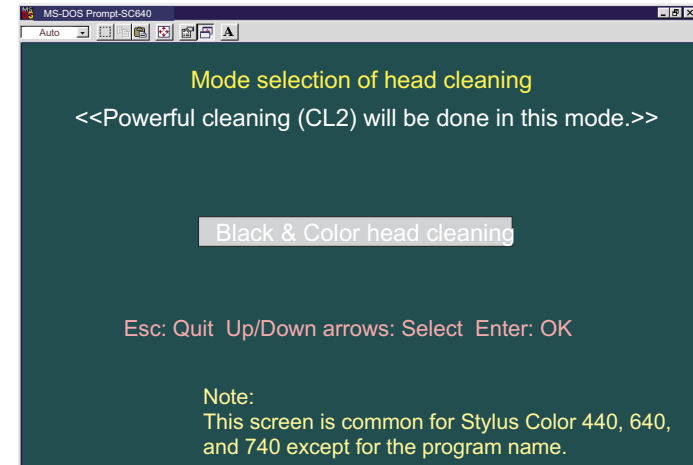

**Figure 5-14. Cleaning Menu**

4. Press the Enter key. The printer enters the CL2 sequence. **(It takes 60 seconds for the process to complete.)**

### 5.2.2.5 Protection Counter Indicate/Reset

The program provided with this manual can let you confirm or clear the current protection counter value. (Of course, you can confirm or clear the current protection value by main unit alone. Refer to table 1-21 and 1-22 for details.)

#### [Confirming the current protection counter value]

1. Enter the main menu. (Refer to Section 5.2.2.2.)
2. Apply the maintenance menu (Figure 5-12).
3. By using the Up/Down arrow key, select **Indication of the counter value for the waste ink pad**. The screen below appears.

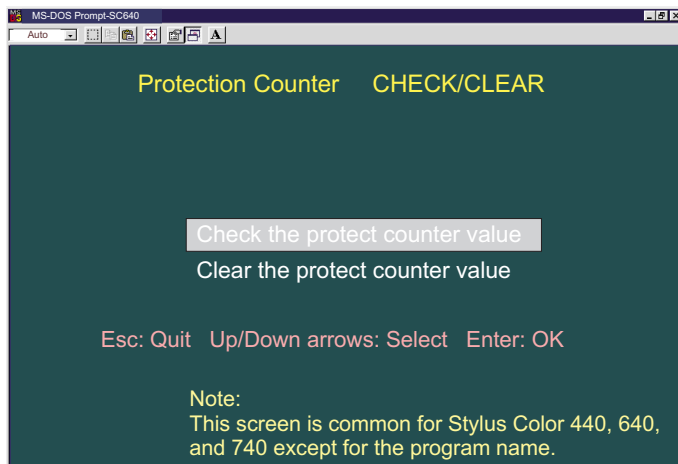

Figure 5-15. Current Protection Counter Conformation (1) Screen

4. Press the Enter key while the reverse cursor is indicating **Check the protect counter value**. The screen below appears.

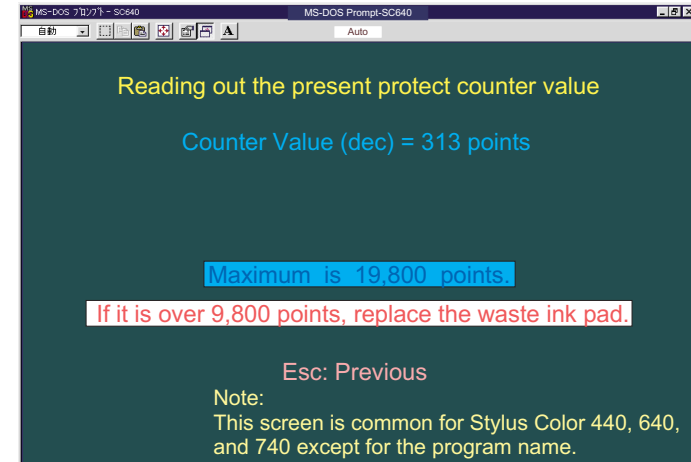

Figure 5-16. Current Protection Counter Conformation (2)

### [Clearing the current protection counter value]

1. Enter the main menu. (Refer to Section 5.2.2.2 )
2. Apply the maintenance menu.
3. By using the Up/Down arrow key, select the item **Indication of the counter value for the waste ink pad** in the maintenance menu (Figure 5-12). The Current Protection Counter Conformation (1) Screen shown in Figure 5-15 appears.
4. By using the Up/Down arrow key, select the **Clear the protect counter value** on the screen. The screen shown below appears.

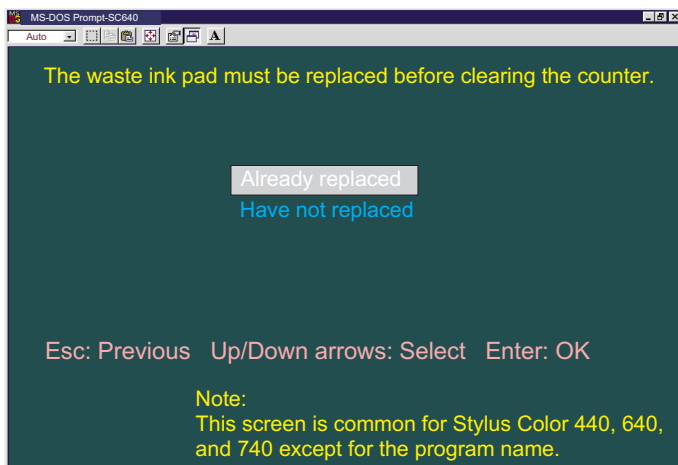

Figure 5-17. Current Protection Counter Clear Screen

5. Press the Enter key while the reverse cursor is indicating **Already replaced**. The screen below appears.

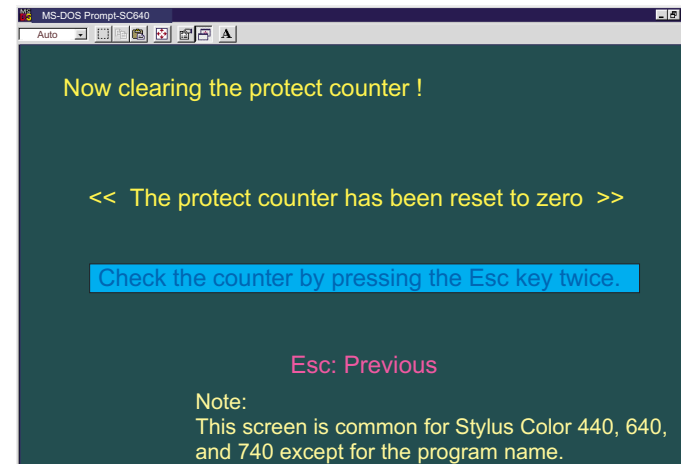

Figure 5-18. Zero Clear of Protect Counter Value



- Be sure to replace the installed waste ink pad with a new one after or before you clear the current protection counter value.
- If you select **Have not replaced**, the current screen automatically returns to the previous screen (Figure 5-17).

### 5.2.2.6 Market/Destination Check (only for Stylus Color 740)

As already mentioned, there are two models for Stylus Color 740, Standard model and NLSP model, and you are required to set the suitable destination depending on the type of the main board supported. Without this operation (Market/destination setting), users can not use the NLSP characters despite their printers are equipped with the CG-ROM(IC6) on the main board.

For this reason, always confirm the market/destination status on the **Destination Setting Screen for Stylus Color 740** (Figure 5-19) after you change or set a CG.



- **Do not select "NLSP" unless your Stylus Color 740 supports the NLSP characters. You can distinguish the NLSP model from the Standard one by checking the following points on the C257 Main board:**
  - \*Standard: There is no IC6 on C257 Main board.
  - \*NLSP: There is IC6 on C257 Main board.
- **On the other hand, if you set the destination to "Standard" despite your Stylus Color 740 supports NLSP characters, they will not be used.**
- **Even though your spare C257 Main board is a NLSP version, it has already been set as a standard version in the EEPROM. Therefore, you have to set it as a NLSP version in the EEPROM after installing a new NLSP version board (with IC6 mounted).**

1. Enter the main menu. (See Section 5.2.2.2 .)
2. Apply the adjustment menu. The following screen appears.

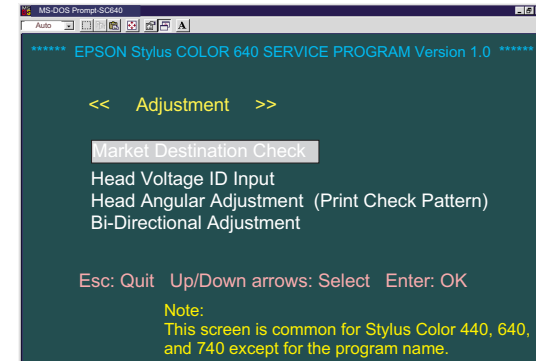

Figure 5-19. Adjustment Menu of the Program

3. By using the Up/Down arrow key, select **Market Destination Check**. The following screen appears.

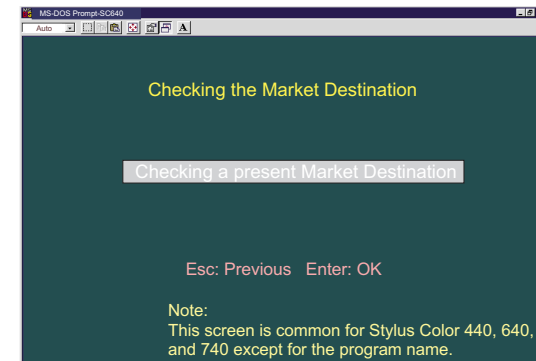
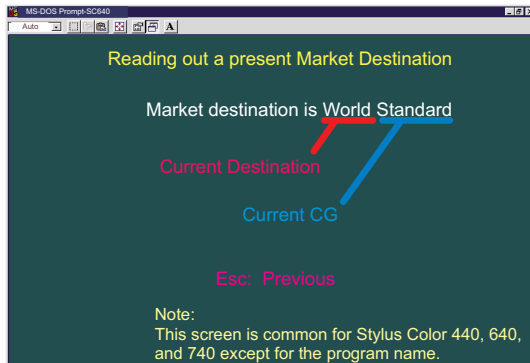

Figure 5-20. Market/Destination Checking Screen



4. Press the Enter key, and the screen below appears. The terms **World** and **Standard** show the current value set in the destination and CG addresses in the EEPROM.



**Figure 5-21. Market/Destination Confirmation Menu**

5. You can return to the adjustment menu by pressing the Esc key twice.

### 5.2.2.7 Head Voltage ID Input

Head voltage value adjustment function enables you to write printhead ID. This operation is considered the most important to maintain proper ink discharging system. If an ID is not written correctly, it results in white or color lines and also gives bad influence on dot weight. This adjustment is required in the following cases.

1. When exchanging the main board
2. When exchanging the printhead
3. When exchanging the printer mechanism



**Before or after performing this operation, refer to the table 5-2 and perform any appropriate adjustments or operations.**

1. When replacing any of the parts above, make a note of VH voltage ID appointed in advance. You can find the VH voltage ID on the following position:
  - Printhead: On the side face of the printhead.
  - Printer mechanism: On the label of the packing box of the printer mechanism.
2. Apply the main menu (Figure 5-21). (See Section 5.2.2.2.)
3. By using the Up/Down arrow key, select **Adjustment** in the main menu.

4. By using the Up/Down arrow key, select **Head Voltage ID Input** in the adjustment menu. (Figure 5-19.)  
The following screen appears.

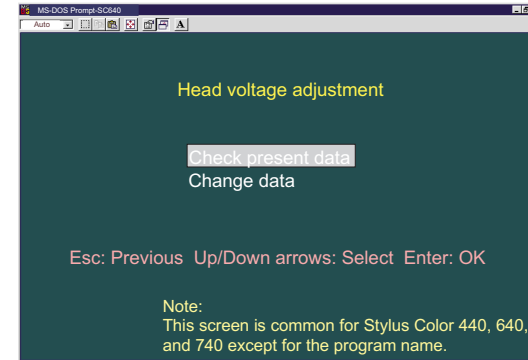

**Figure 5-22. Head Voltage ID Check/Input Select Menu**

5. By using Up/Down arrow key, select **Change data**, and the following screen appears.

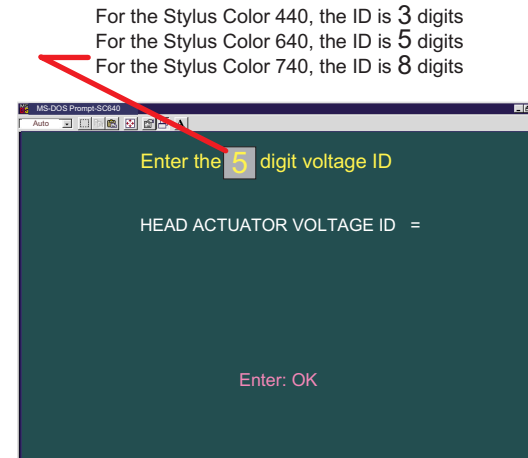

**Figure 5-23. Head Voltage ID Input Menu**

6. When you input the head ID value, the screen automatically advances consequently, as shown below:

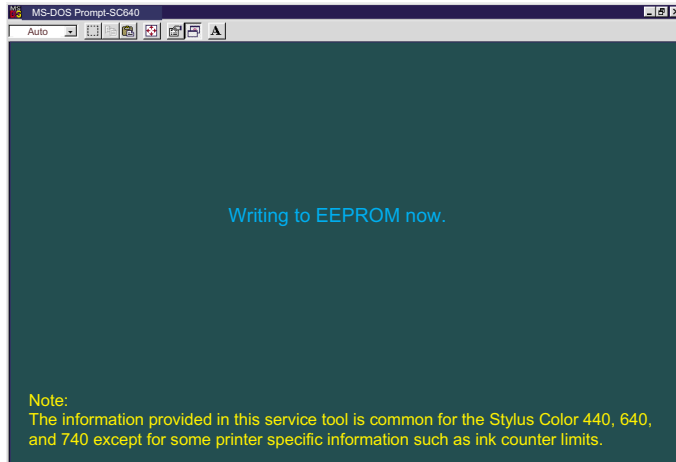

This process takes about 5 seconds.

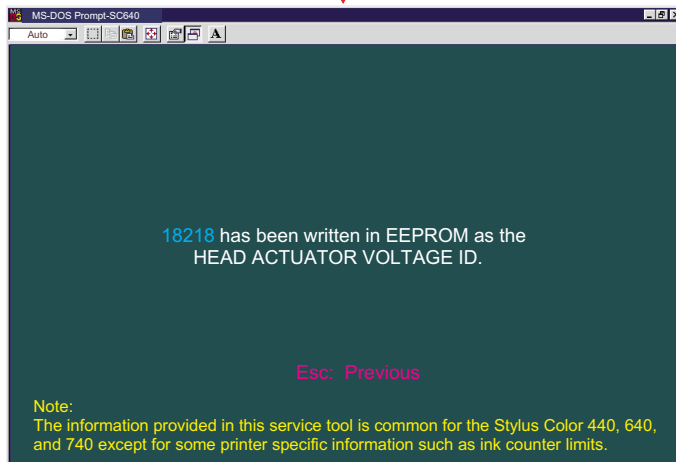

Figure 5-24. Head Voltage ID Writing Screen

7. Press the Esc key once. The screen returns to the Head Voltage ID Check/Input Select Menu. (See Figure 5-22.)
8. By using the Up/Down arrow key, select **Check present data** on the screen. The screen below appears.

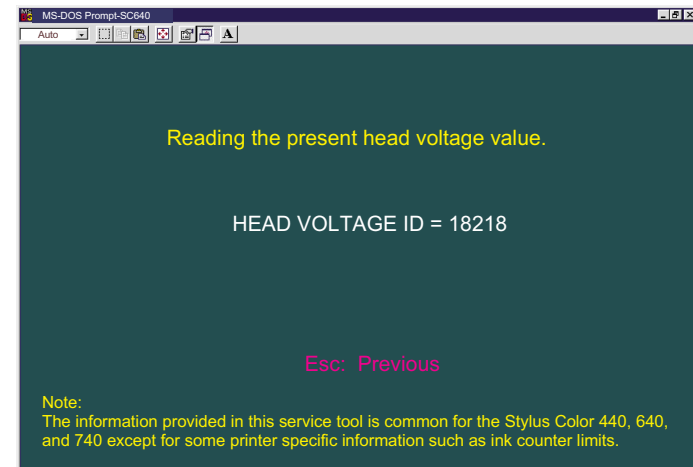

Figure 5-25. Input ID Confirmation Menu

### 5.2.2.8 Head Angular Adjustment

During production, slight variations are created in printheads and carriage (which are used as a printhead base.) If these differences are not adjusted, they can adversely influence the printhead angle, and color overlapping is not performed correctly and color/white line problem occurs as a result. Therefore, in order to adjust the printhead angle correctly, the exclusive lever for adjusting the printhead angle is installed on the side of the carriage unit. By moving this lever, you are able to adjust the printhead angle without removing the ink cartridge. This adjustment is required in the following cases.

- When a printhead is replaced.
- When the carriage unit is replaced.
- When the angle adjustment lever is moved.

Print the check pattern in the adjustment program to determine the angle degree needed for the printhead. Then move the adjustment lever in the carriage unit to set the printhead angle referring to the printed check pattern.



**Before or after performing this operation, refer to Table 5-2 and perform appropriate adjustments or operations.**

1. Remove the upper case from the main unit. (Refer to Chapter 4.)

**NOTE:**

*If you perform this adjustment with the upper case installed, select “**Move the carriage to the head angular adjustment position**” on Current Head Angular Confirmation Menu (1) screen (Figure 5-26) before loosening the screw.*

2. Apply the main menu (Figure 5-21). (See Section 5.2.2.2.)
3. By using the Up/Down arrow key, select **Adjustment** in the main menu. By using the Up/Down arrow key, select **Head Angular Adjustment**. The following screen appears.

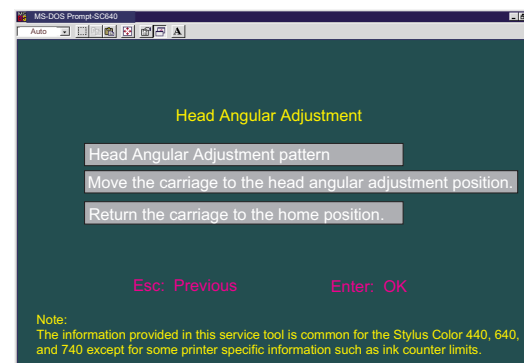

**Figure 5-26. Current Head Angular Confirmation Menu (1)**

4. Select Head Angular Adjustment Pattern and press Enter key. The screen below appears and the printer prints the head angular adjustment pattern (Figure 5-28).

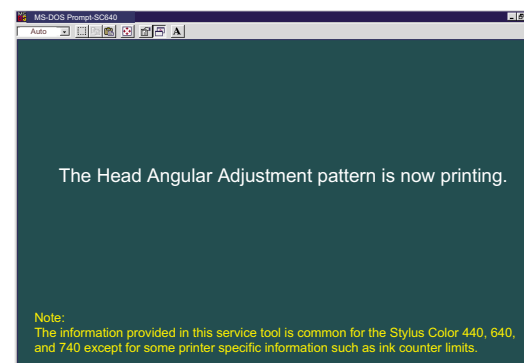

**Figure 5-27. Current Head Angular Confirmation Menu (2)**



Figure 5-28. Sample of Head Angular Adjustment Pattern

- Loosen the printhead securing screw securing the printhead on the carriage. (You don't need to remove it completely.)

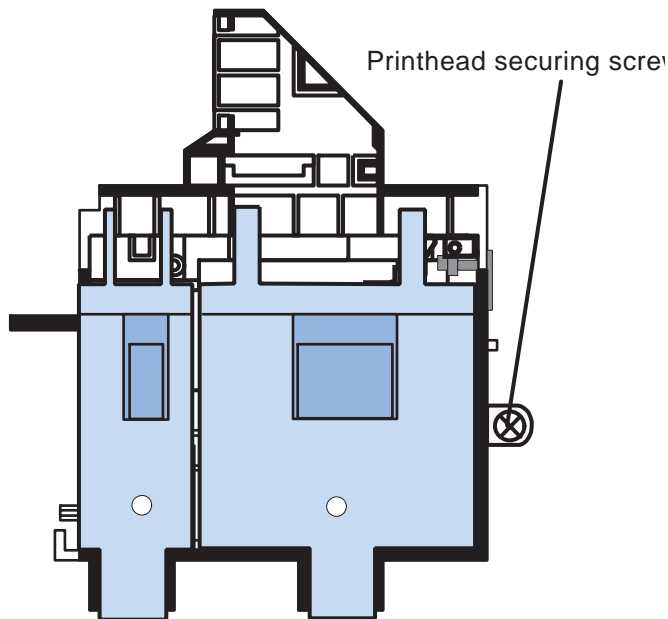

Figure 5-29. . Screw Position

**NOTE:** Make sure to loosen this screw. Otherwise, the printhead angle will no change even if the adjusting lever moves.

- Look at the black/magenta combination in the pattern and move the adjusting lever to make the magenta lines stay between the black lines with even space. The figure below shows how the pattern changes as the adjusting lever moves right (rear) or left (front).

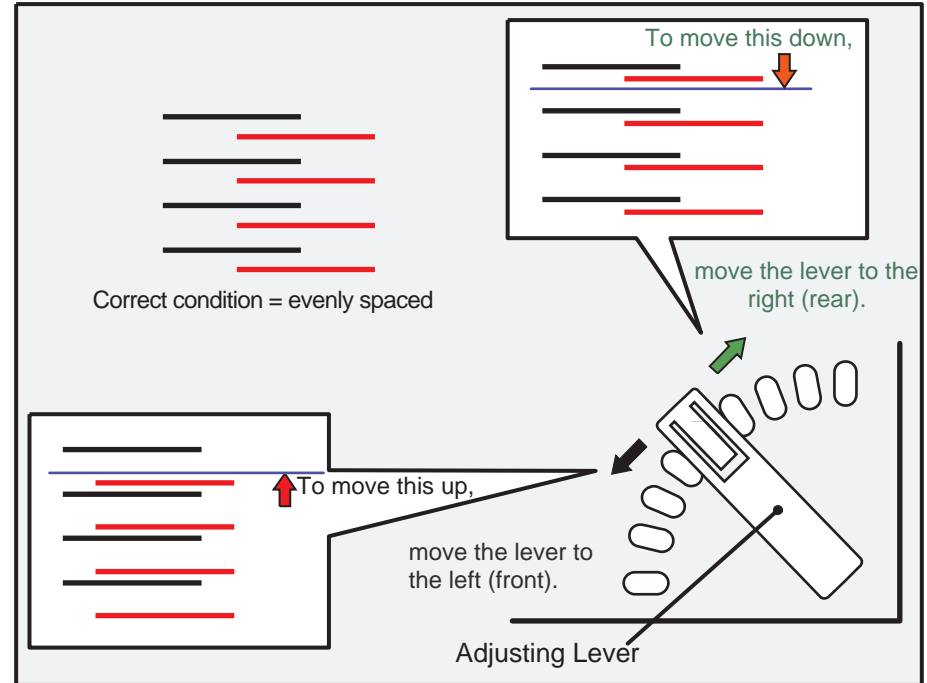
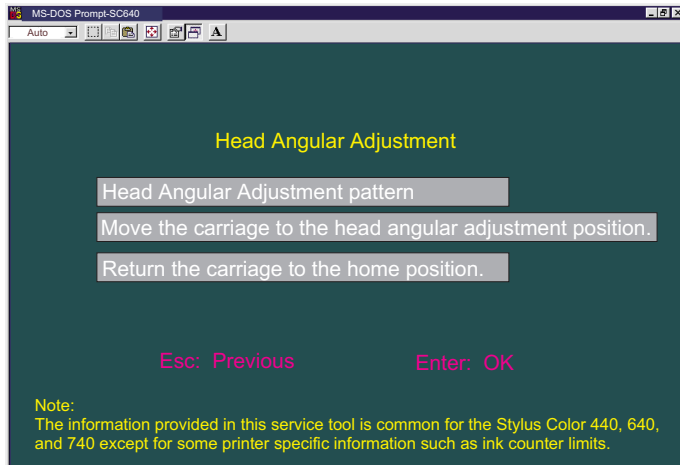

Figure 5-30.

Lever Operation and Corresponding Change in Pattern

- After changing the position of the adjust lever, select Head angular adjustment pattern again. The printer prints out a head angular adjustment pattern and the screen automatically returns to the Current Head Angular Confirmation Menu (1) shown in the figure below.



**Figure 5-31. Current Head Angular Confirmation Menu (1)**

- Verify the pattern on the printout again.
- Repeat the procedures from Step 5 to Step9 until the combination pattern of black/magenta is correct.
- After completing the adjustment, tighten the loosened screw, and reinstall the upper case only when you remove it.

### 5.2.2.9 Bi-D Adjustment

You perform this adjustment to correct differences in printing positions, which is caused by slippage of printing timing in right and left directions during the Bi-directional printing. Therefore, you are required to perform this adjustment after performing the following operations.

- Replacing the Print mechanism
- Replacing the main board
- Replacing the CR motor
- Replacing the Carriage Assembly
- Replacing the Printhead

1. Apply the main menu (Figure 5-21). (See Section 5.2.2.2.)
2. By using the Up/Down arrow key, select **Adjustment** in the main menu.
3. By using the Up/Down arrow key, select **Bi-Directional Adjustment** in the adjustment menu. (See Figure 5-19.) The following screen appears.

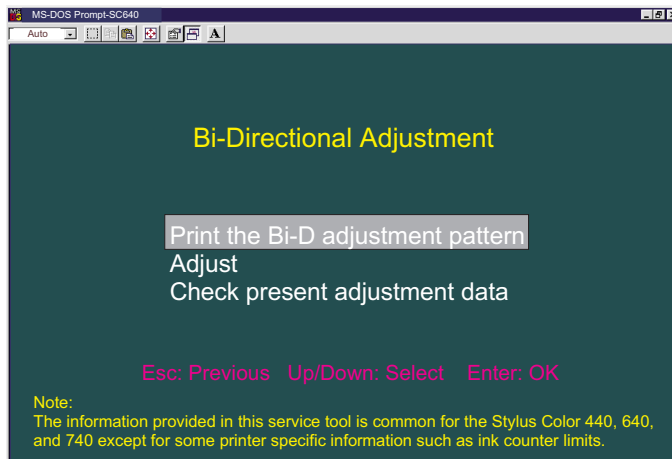

Figure 5-32. Bi-D Adjustment Menu

4. By using the Up/Down arrow key, select **Print the Bi-D adjustment pattern** on the screen, and the screen below appears.

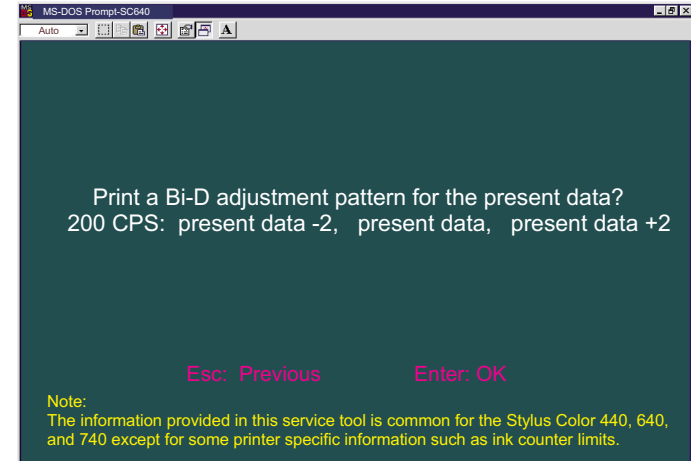

Figure 5-33. Before Printing the Bi-D pattern

5. Press the Enter key. The printer starts printing a Bi-D adjustment pattern. (See the sample pattern in the following page.)

**NOTE:**

*As shown in the sample, gaps between passes are sometimes created in different directions among patterns.*

*This unexpected change in direction is caused by an ink jet printer-specific reason, which is an ink jet printer inevitably performs a periodical cleaning specified by the flashing timer even during Bi-D pattern printing, so that the printing direction suddenly changes. However, this directional difference among Bi-D patterns should not be considered, and you can always confirm and adjust the pattern correctly by referring to gap amount only.*

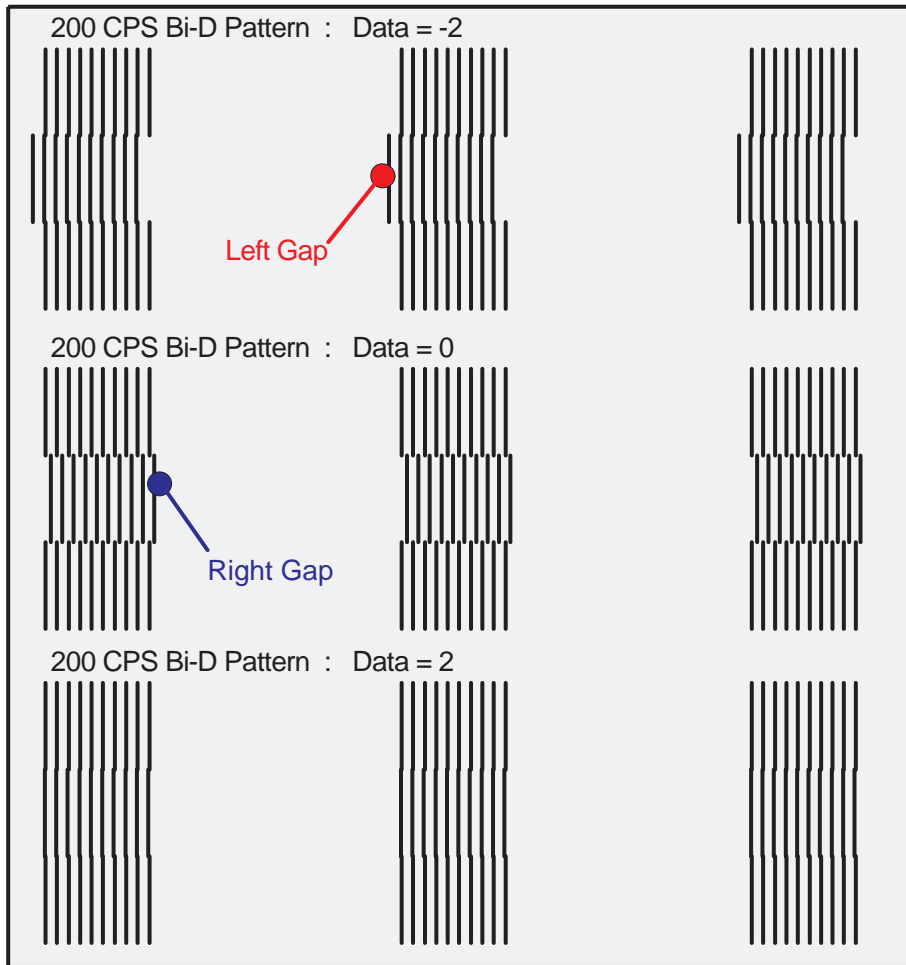

Figure 5-34. Bi-D ADjustment Pattern Sample

- By using the Up/Down key, select **Adjust** on the Bi-D adjustment menu (Figure 5-32). Then the screen below appears.

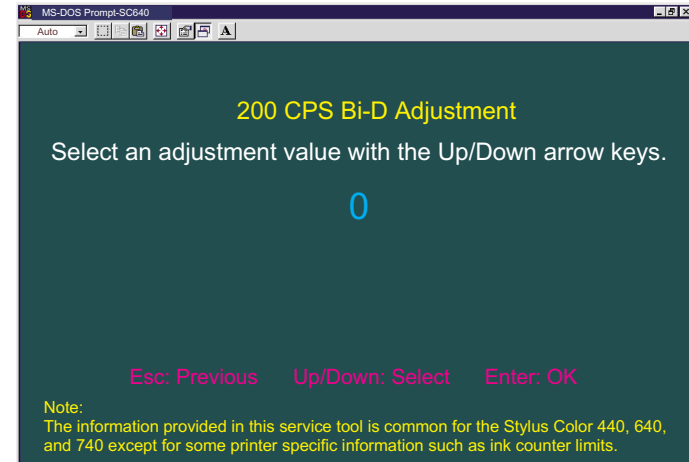

Figure 5-35. Bi-D Value Input Menu

- The value **0** (blue) appears in the center of the screen and changes up/down every time you press the Up/Down arrow key. Using the keys, apply the number for the most properly aligned pattern in the Bi-D adjustment pattern print.
- After you set the value correctly, press the Enter key, and the program stores the selected value.
- Press the Esc key once. The current screen returns to the Bi-D adjustment menu. (See Figure 5-32.)
- Repeat the procedure from Step3 to Step9 until the Bi-D adjustment pattern is correct.



**CHAPTER**

**6**

**MAINTENANCE**

## 6.1 Overview

---

This section describes the points and the procedures for maintaining the printer in its optimum condition.

### 6.1.1 Cleaning

This printer has no mechanical components which require regular cleaning. Therefore, note that the points suggested below are only to check for dirt, and perform appropriate cleaning if necessary.



- **Never use chemical solvents, such as thinner, to clean the printer. These chemicals can damage the components of the printer.**
- **Be careful not to damage the components when you attempt to clean the inside the printer.**
- **Do not scratch surface of “ROLLER, ASSEMBLY, PF”. (Use soft brush to wipe off any dusts, or use a soft cloth moistened with alcohol.)**

- **Housing:**  
Use a clean soft cloth moistened with water and wipe off any dirt. If the housing is stained with ink, use a cloth moistened with neutral detergent to wipe it off.
- **Inside the printer:**  
Use a vacuum cleaner to remove any paper dust.

### 6.1.2 Service Maintenance

If print irregularity (missing dot, white line, etc.) has occurred or the printer indicates “MAINTENANCE ERROR”, take the following actions to clear the error.

- **Head Cleaning**  
The printer has a built-in head cleaning function and is activated through the control panel operation.
  1. Confirm that the printer is in stand-by state (the POWER indicator is not blinking), and hold down the cleaning button on the control panel for more than 3 seconds.
  2. The printer enters the built-in cleaning sequence. (During the sequence, the POWER indicator is blinking.)
- **Maintenance Error Clear**  
Ink is used for the operations such as cleaning as well as printing. Therefore, the printer wastes certain amount of ink and counts the amount of waste ink and drains it into the waste ink pad. Once the amount of waste ink reaches the predefined limit, the printer indicates “MAINTENANCE ERROR” and the waste ink pad should be replaced.  
(See Chapter 1 / Page 1-25 for details.)

### 6.1.3 Lubrication

The type and amount of oil and grease used to lubricated the printer parts are determined based on the results of internal evaluations. Therefore, be sure to apply the specified type and amount of oil and grease to the specified part of the printer mechanism during servicing.



- **Never use oil and the grease other than those specified in this manual. Use of different types of lubricant can damage the printer and the components.**
- **Never apply larger amount of lubricant than specified in this manual.**

**Table 6-1. Specified Lubricants**

Type	Name	EPSON Code	Supplier
Grease	G-26	B702600001	EPSON
Oil	O-12	1038991	EPSON

**Table 6-2. Lubrication Point**

No.	Standard	Remarks
1	<Lubrication Point> Contact between "ROLLER, PF" and "PAPER GUIDE, REAR"	Do not put grease around the paper path. Use a syringe to apply it. Apply grease while rotating "GEAR, 67.2".
	<Lubricant Type> G-26	
	<Lubrication Amount> A half turn of "ROLLER, PF"	
2	<Lubrication Point> Contact points between "PAPER GUIDE, FRONT" and each roller: "ROLLER, PF" (1 point) "ROLLER, EXIT" (2 points)	Lubricate the contact points between the hooks on "PAPER GUIDE, FRONT" and each roller. Avoid applying grease around the paper path. Use a syringe to apply it.
	<Lubricant Type> G-26	
	<Lubrication Amount> 10-mm long 2-mm long	
3	<Lubrication Point> Contact points between the carriage assembly and "FRAME, UPPER"	Verify that the carriage moves smoothly after lubricating it. Use a syringe to apply it.
	<Lubricant Type> G-26	
	<Lubrication Amount> Range from the HP sensor installation point to the point where "GUIDE PLATE, CABLE" is attached.	
4	<Lubrication Point> Gears: "GEAR, 67.2" "COMBINATION GEAR, 8, 14.4" "GEAR, 23.2"	Rotate the gears after applying grease to evenly distribute it. Use a syringe to apply it.
	<Lubricant Type> G-26	
	<Lubrication Amount> 1/4 of gear tooth 1/3 of gear tooth 1/3 of gear tooth 1/3 of gear tooth	

Table 6-2. Lubrication Point

No.	Standard	Remarks
5	<Lubrication Point> The shaft for "GEAR, 16, 40.8" on "FRAME, LEFT"	Use a syringe to apply it.
	<Lubricant Type> G-26	
	<Lubrication Amount> Approximately 5-mm long	
6	<Lubrication Point> Bushings for "ROLLER, PF" Left: Inside the bushing Right: Inside the bushing (near the pump assembly)	For the right bushing, apply it from the paper path side, and wipe off any grease sticking out to the cap assembly side. Rotate "ROLLER, PF" after applying grease to evenly distribute it in the bushing.
	<Lubricant Type> G-26	
	<Lubrication Amount> Approximately 3 mm diametrically	Use a syringe to apply it.
7	<Lubrication Point> Both Left/Right Bushings for "ROLLER, EXIT"	Avoid applying grease around the paper path. Use a syringe to apply it.
	<Lubricant Type> G-26	
	<Lubrication Amount> Evenly apply inside the bushings.	
8	<Lubrication Point> Contact points between "HOLDER, PULLEY, DRIVEN" and "FRAME, UPPER"	Verify that the holder slides only with spring force after applying grease. Use a syringe to apply it.
	<Lubricant Type> G-26	
	<Lubrication Amount> 2-mm long for each point	
9	<Lubrication Point> ASF; The round hole in the right frame of ASF (to hold the roller shaft)	Avoid applying grease to "ROLLER, ASSEMBLY, LD".
	<Lubricant Type> G-26	
	<Lubrication Amount> Evenly apply inside the hole.	

Table 6-2. Lubrication Point

No.	Standard	Remarks
10	<Lubrication Point> ASF; Contact points between "HOPPER" and "LEVER, HOPPER, RELEASE"	Completely wipe off any grease sticking out to the inner side of ASF.
	<Lubricant Type> G-26	
	<Lubrication Amount> Evenly apply lubrication to the points.	
11	<Lubrication Point> The round cutout in the left frame of ASF ("GEAR, 34" is inserted to the cutout.)	Completely wipe off any grease sticking out to the inner side of ASF.
	<Lubricant Type> G-26	
	<Lubrication Amount> Evenly apply inside the hole	
12	<Lubrication Point> Oil pad in the carriage assembly	Lubricate the oil pad only when; *Replacing the carriage assembly *Replacing the oil pad Use a precise syringe to apply it. If you accidentally apply too much oil to the oil pad, throw the pad away and take a new one again. Leave the oil pad for a while to wait until oil is evenly infiltrated, then install it on the carriage assembly.
	<Lubricant Type> O-12	
	<Lubrication Amount> 0.7 cc <b>Note:</b> This is the amount to be applied to a new oil pad.	



- Never apply oil to the CR guide shaft directly. This may cause fatal damage to the components of the printer.
- Avoid applying oil excessively to the oil pad. This may cause fatal damage to the components of the printer.

*\*Never apply the oil exceeding 0.6cc.*

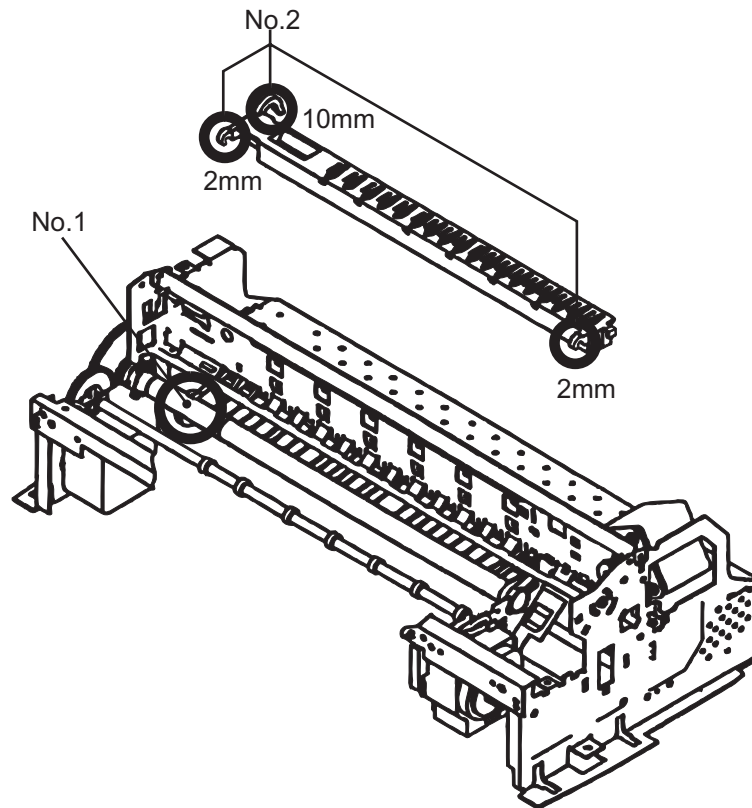
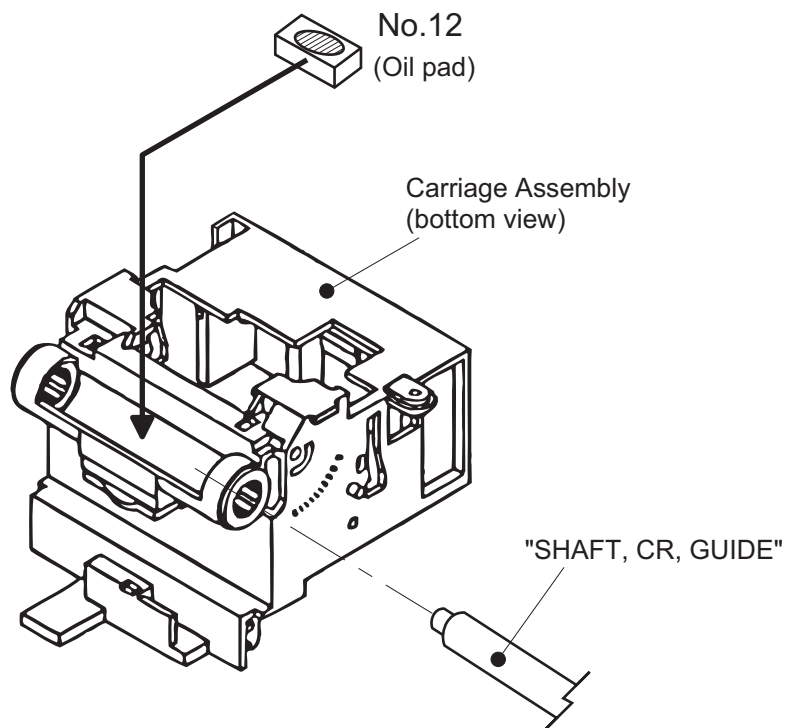

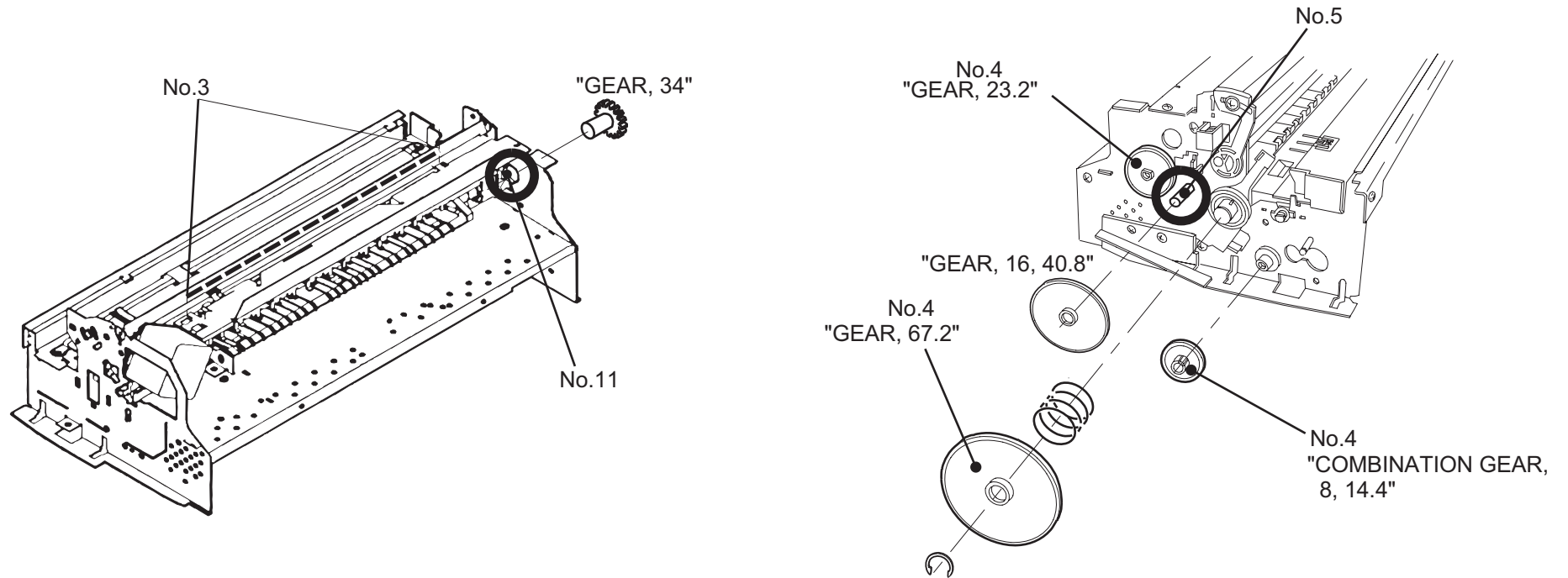

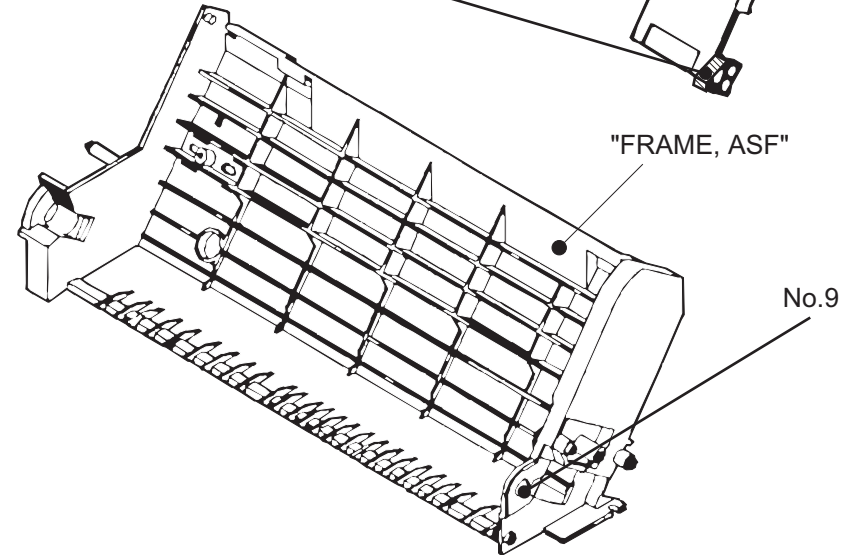
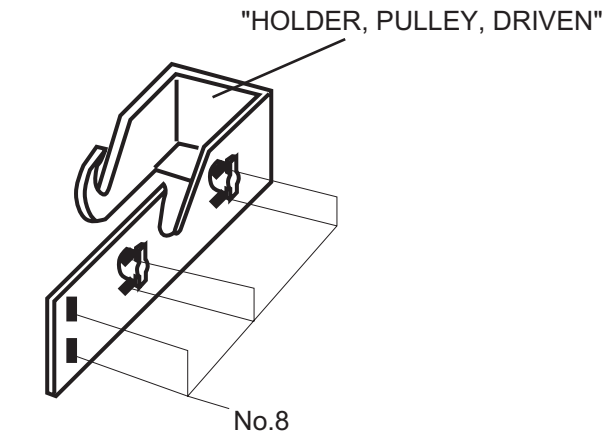
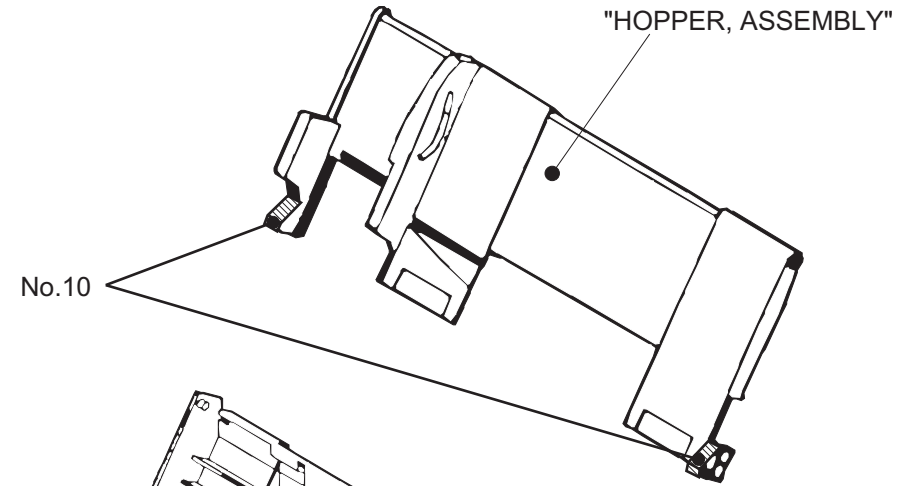
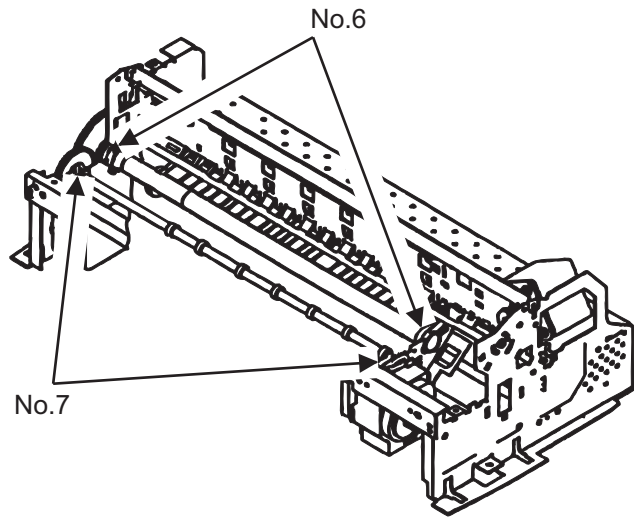

**CHAPTER**

**7**

**APPENDIX**



## A.1 Connector Summary

---

This section gives information on connectors and their pin assignment. Since all connectors and their pin assignments except for CN8 (printhead) are common for Stylus Color 440 and Stylus Color 640, they are included in one section ([Section A.1.1.](#)) Refer to [Section A.1.2](#) for the connector summary for Stylus Color 740. Each section includes the following information.

### Section A.1.1 (Stylus Color 440/640)

- C206MAIN-B, C255MAIN (Stylus Color 440)
- C256MAIN (Stylus Color 640)
- C206PSB/PSE (Stylus Color 440, Stylus Color 640)
- Printer Mechanism

### Section A.1.2 (Stylus Color 740)

- C257MAIN
- C257PSB/PSE
- Printer mechanism

### A.1.1 Connector Summary (Stylus Color 440/640)

This section provides information on connectors in the main units of the Stylus Color 440 and Stylus Color 640. Figure 1 shows how the main component units are connected.



Information contained in this section only applies to Stylus Color 440 and Stylus Color 640.



If you need information on Stylus Color 740, go to Section A.1.2.

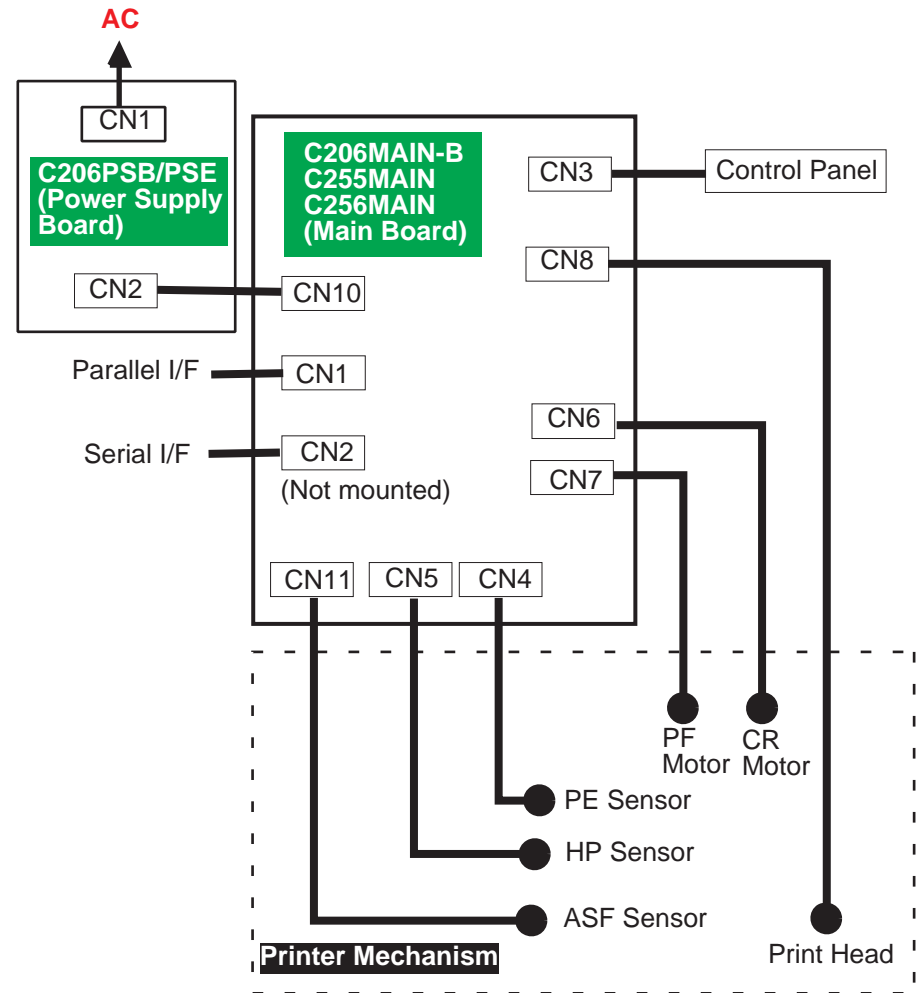

Figure A-1. Cable Connection of Stylus Color 440/640

### A.1.1.1 Connector Pin Assignment (Stylus Color 440 and Stylus Color 640)

Tables in this section provide connector pin assignments of the C206MAIN-B, C255MAIN and C256MAIN, the main boards equipped with Stylus Color 440 and Stylus Color 640.



**Information contained in this section only applies to Stylus Color 440 and Stylus Color 640.**



**Pin assignments for all connectors but CN8 (Printhead) are common. Therefore they are combined in the same tables. As for CN8 (printhead), separate tables are provided as shown below.**

- Table A-7: CN8 for C206MAIN-B, C255MAIN
- Table A-8: CN8 for C256MAIN



**If you need information on Stylus Color 740, go to Section A.1.2.1.**

**Table A-1.  
Connector Summary of C206MAIN-B/C255MAIN/C256MAIN**

Connector	Function	Table to refer to
CN1	Parallel I/F connector	Chapter 1/Table 1-10
CN2	Serial I/F connector	Chapter 1/Table 1-16
CN3	To Control panel	Table A-2
CN4	To PE sensor	Table A-3
CN5	To HP sensor	Table A-4
CN6	To CR motor	Table A-5
CN7	To PF motor	Table A-6
CN8	To Printhead	Table A-7
CN10	To Power supply board	Table A-9
CN11	To ASF sensor	Table A-10

**Table A-2. Connector CN3**

Pin	Signal Name	I/O	Function
1	LED0	Out	LED drive signal (0)
2	GND	----	Ground
3	LED1	Out	LED drive signal (1)
4	GND	----	Ground
5	LED2	Out	LED drive signal (2)
6	+5V	----	Logic power supply
7	+5V	----	Logic power supply
8	LED4	Out	LED drive signal (4)
9	SW1	In	Panel switch input (1)
10	PSC	In	Power on/off switch
11	SW0	In	Panel switch on/off (0)
12	SW2	In	Panel switch on/off (2)

**Table A-3. Connector CN4**

Pin	Signal Name	I/O	Function
1	PE	In	Sensor detect signal
2	GND	---	Ground
3	PEV	---	Sensor power supply (+5V)

**Table A-4. Connector CN5**

Pin	Signal Name	I/O	Function
1	HP	In	Sensor detect signal
2	GND	---	Ground
3	HPV	---	Sensor power supply(+5V)

Table A-5. Connector CN6

Pin	Signal Name	I/O	Function
1	CRA	Out	Phase drive signal (A)
2	CRB	Out	Phase drive signal (B)
3	CR-A	Out	Phase drive signal (-A)
4	CR-B	Out	Phase drive signal (-B)

Table A-6. Connector CN7

Pin	Signal Name	I/O	Function
1	PFA	Out	Phase drive signal (A)
2	PFB	Out	Phase drive signal (B)
3	PF-A	Out	Phase drive signal (-A)
4	PF-B	Out	Phase drive signal (-B)

Table A-7. Connector CN8 (C206MAIN-B, C255MAIN)

Pin	Signal Name	I/O	Function
1	BCO	In	Black ink cartridge detect signal
2	CCO	In	Color ink cartridge detect signal
3	THM	In	Thermistor detect signal
4	GND	---	Ground
5	LAT	Out	Head data latch pulse output
6	GND	---	Ground
7	SI2	Out	Head data output (2)
8	GND	---	Ground
9	SI1	Out	Head data output (1)
10	GND	---	Ground
11	CLK	Out	Head data output (1)
12	GND	---	Ground
13	NCHG	Out	Head all on pulse output
14	GND	---	Ground
15	VDD	---	Logic power supply (+5V)
16	GND2	---	Ground
17	GND2	---	Ground
18	GND2	---	Ground
19	COM	---	Head drive power supply
20	COM	---	Head drive power supply
21	COM	---	Head drive power supply
22	VHV	---	Head drive voltage control signal
23	VHV	---	Head drive voltage control signal

Table A-8. Connector CN8 (C256MAIN)

Pin	Signal Name	I/O	Function
1	BCO	In	Black ink cartridge detect signal
2	CCO	In	Color ink cartridge detect signal
3	THM	In	Thermistor detect signal
4	GND	---	Ground
5	LAT	Out	Head data latch pulse output
6	GND	---	Ground
7	SI3	Out	Head data output (3)
8	GND	---	Ground
9	SI2	Out	Head data output (2)
10	GND	---	Ground
11	SI1	Out	Head data output (1)
12	GND	---	Ground
13	CLK	Out	Clock pulse for head data transfer
14	GND	---	Ground
15	NCHG	Out	Head all on pulse output
16	GND	---	Ground
17	VDD	---	Logic power supply (+5V)
18	GND2	---	Ground
19	GND2	---	Ground
20	GND2	---	Ground
21	COM	---	Head drive power supply
22	COM	---	Head drive power supply
23	COM	---	Head drive power supply
24	VHV	---	Head drive voltage control signal
25	VHV	---	Head drive voltage control signal

Table A-9. Connector CN10

Pin	Signal Name	I/O	Function
1	+42V	---	Mechanism drive power supply
2	+42V	---	Mechanism drive power supply
3	GND	---	Ground
4	GND	---	Ground
5	PSC	Out	Power supply switch output signal
6	GND	---	Ground
7	GND	---	Ground
8	+5V	---	Logic power supply

Table A-10. Connector CN11

Pin	Signal Name	I/O	Function
1	ASF	In	Sensor detect signal
2	GND	---	Ground
3	ASFV	---	Sensor power supply (+5V)

### A.1.2 Connector Summary for Stylus Color 740

This section contains information on connectors in the main units of Stylus Color 740. Figure 2 shows how the main component units of the Stylus Color 740 are connected.



**Information contained in this section only applies to Stylus Color 740.**



**If you need information on Stylus Color 440 and Stylus Color 640, return to Section A.1.1.**

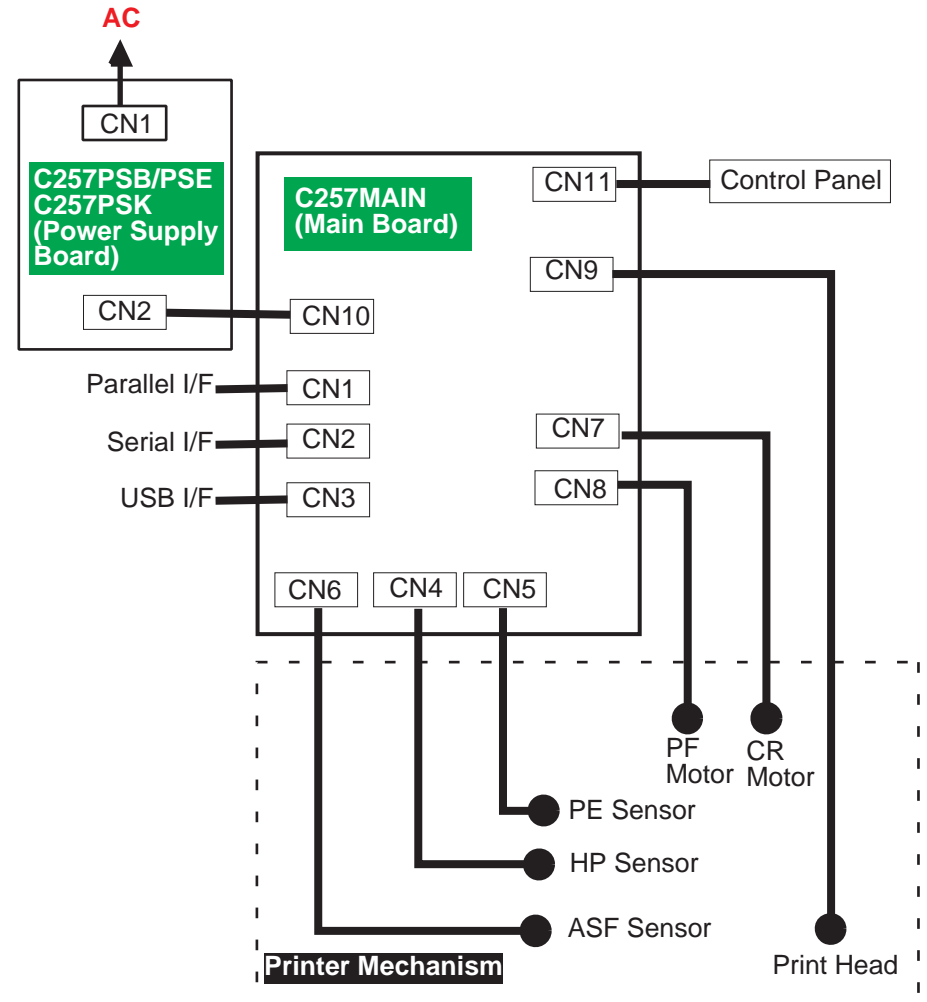

Figure A-2. Cable Connection of the Stylus Color 740

### A.1.2.1 Connector Pin Assignment (Stylus Color 740)

Tables in this section provide connector pin assignments of the C257MAIN, the main board equipped with Stylus Color 740.



**Information contained in this section only applies to Stylus Color 740.**



**If you need information on Stylus Color 440 and Stylus Color 640, return to Section A.1.1.1.**

**Table A-11. Connector Summary of C257MAIN**

Connector	Function	Table to refer to
CN1	Parallel I/F connector	Chapter 1/Table 1-10
CN2	Serial I/F connector	Chapter 1/Table 1-16
CN3	SUB I/F connector	Chapter 1/Table 1-18
CN4	To HP sensor	Table A-12
CN5	To PE sensor	Table A-13
CN6	To ASF sensor	Table A-14
CN7	To CR motor	Table A-15
CN8	To PF motor	Table A-16
CN9	To Printhead	Table A-17
CN10	To Power supply board	Table A-18
CN11	To Control panel	Table A-19

**Table A-12. Connector CN4**

Pin	Signal Name	I/O	Function
1	HP	In	Sensor detect signal
2	GND	---	Ground
3	HPV	---	Sensor power supply(+5V)

**Table A-13. Connector CN5**

Pin	Signal Name	I/O	Function
1	PE	In	Sensor detect signal
2	GND	---	Ground
3	PEV	---	Sensor power supply (+5V)

**Table A-14. Connector CN6**

Pin	Signal Name	I/O	Function
1	ASF	In	Sensor detect signal
2	GND	---	Ground
3	ASFV	---	Sensor power supply (+5V)

**Table A-15. Connector CN7**

Pin	Signal Name	I/O	Function
1	CRA	Out	Phase drive signal (A)
2	CR-A	Out	Phase drive signal (-A)
3	CRB	Out	Phase drive signal (B)
4	CR-B	Out	Phase drive signal (-B)

**Table A-16. Connector CN8**

Pin	Signal Name	I/O	Function
1	PFA	Out	Phase drive signal (A)
2	PFB	Out	Phase drive signal (B)
3	PF-A	Out	Phase drive signal (-A)
4	PF-B	Out	Phase drive signal (-B)

Table A-17. Connector CN9

Pin	Signal Name	I/O	Function
1	BCO	In	Black ink cartridge detect signal
2	CCO	In	Color ink cartridge detect signal
3	THM	In	Thermistor detect signal
4	GND	---	Ground
5	LAT	Out	Head data latch pulse output
6	GND	---	Ground
7	SI6	Out	Head data output (6)
8	SI5	Out	Head data output (5)
9	SI4	Out	Head data output (4)
10	SI3	Out	Head data output (3)
11	SI2	Out	Head data output (2)
12	SI1	Out	Head data output (1)
13	GND	---	Ground
14	CLK	Out	Clock pulse for head data transfer
15	GND	---	Ground
16	NCHG	Out	Head all on pulse output
17	GND	---	Ground
18	VDD	---	Logic power supply (+5V)
19	GND2	---	Ground
20	GND2	---	Ground
21	GND2	---	Ground
22	GND2	---	Ground
23	COM	---	Head drive power supply
24	COM	---	Head drive power supply
25	COM	---	Head drive power supply
26	COM	---	Head drive power supply
27	VHV	---	Head drive voltage control signal

Table A-18. Connector CN10

Pin	Signal Name	I/O	Function
1	+42V	---	Mechanism drive power supply
2	+42V	---	Mechanism drive power supply
3	GND	---	Ground
4	GND	---	Ground
5	PSC	Out	Power supply switch output signal
6	GND	----	Ground
7	GND	---	Ground
8	+5V	---	Logic power supply

Table A-19. Connector CN11

Pin	Signal Name	I/O	Function
1	SW2	In	Panel switch on/off (2)
2	SW0	In	Panel switch on/off (0)
3	PSC	In	Power on/off switch
4	SW1	In	Panel switch input (1)
5	LED3	Out	LED drive signal (3)
6	+5V	----	Logic power supply
7	+5V	----	Logic power supply
8	LED2	Out	LED drive signal (2)
9	GND	----	Ground
10	LED1	Out	LED drive signal (1)
11	GND	----	Ground
12	LED0	Out	LED drive signal (0)



## A.2 EEPROM Address Map

---

This section contains EEPROM map for Stylus Color 440/640 and Stylus Color 740. As it is in Section A.2, this section is separated in 2 parts as shown below. Therefore, be sure to refer to the correct section depending on the printer model.

-  **Section A.2.1**  
**EEPROM map for Stylus Color 440 and Stylus Color 640**
-  **Section A.2.2**  
**EEPROM map for Stylus Color 740**

### A.2.1 EEPROM ADDRESS Map (Stylus Color 440/640)

This section provides EEPROM address map for the Stylus Color 440 and Stylus Color 640. Since the contents of the EEPROM maps of the main boards (C206MAIN-B, C255MAIN, and C256MAIN) are mostly common, they are combined into one table except for some addresses.



**EEPROM map in this section only applies to Stylus Color 440 and Stylus Color 640.**



**Be aware that some address rows are separated for Stylus Color 440 and Stylus Color 640, and each row stores the model-specific information. Therefore, be sure to follow the correct row for the model.**



**If you need EEPROM map for Stylus Color 740, go to Section A.2.2.**

**Table A-20.**  
**Stylus Color 440/640 EEPROM Address Map**

Address	Explanation	Setting	QPIT Settings	Factory Settings
00H	Password 0		54H	-
01H			0FH	-
02H	Market	0: Word	00H	(*1)
		1: Japan		(*3)
		2: Custom (MJ)**		
		3: Custom (Stylus Color)**		
	4: Custom (other name)**			
03H	1st dot adjustment	-40 ≤ n ≤ 40 (by 1/1440 inch)	00H	(*1)
04H	Bi-D adjustment data	-36 ≤ n ≤ 36 (by 1/1440 inch)	00H	(*1)
05H	Uni-D adjustment data	-36 ≤ n ≤ 36 (by 1/1440 inch)	00H	(*1)
06H	Stylus Color 440 Reserved		00H	-
	Stylus Color 640 CG	0: STD 1: NLSP	00H	(*1)
07H	Reserved		00H	-
08H	Carriage speed adjustment data	-4 ≤ n ≤ 4 (by G.A timer unit)	00H	(*1)
09H	Stylus Color 440 Reserved		00H	-
	Stylus Color 640 Carriage speed adjustment data for 1440 dpi	-4 ≤ n ≤ 4 (by G.A timer unit)	00H	(*1)
0AH	Head actuator rank ID for VhN		12H	(*1)
0BH	Head actuator rank ID for Twh2		01H	(*1)

**Table A-21.**  
**Stylus Color 440/640 EEPROM Address Map (Continued)**

Address	Explanation	Setting	QPIT Settings	Factory Settings
0CH	Stylus Color 440 Reserved		00H	(*1)
	Stylus Color 640 Head actuator rank ID for VhM		10H	(*1)
0DH	Stylus Color 440 Reserved		00H	-
	Stylus Color 640 Head actuator rank ID for VhMS		00H	(*1)
0EH	Reserved		00H	-
0FH	Reserved		00H	-
10H	Password 1		5AH	-
11H		0FH	-	
12H	Custom EEPROM sub number		00H	00H
13H		00H	00H	
14H		00H	00H	
15H		00H	00H	
16H	Reserved		00H	-
17H	Reserved		00H	-
18H	CPSI password		00H	00H
19H		00H	00H	
1AH		00H	00H	
1BH		00H	00H	
1CH	CPSI flags	bit7: CPSI license 0: Disable, 1: Enable bit6: CPSI Font license 0: Disable, 1: Enable	00H	00H
1DH	Reserved		00H	-
1EH	Reserved		00H	-
1FH	EEPROM Revision		42H	-

Table A-22.

Stylus Color 440/640 EEPROM Address Map (Continued)

Address	Explanation	Setting	QPIT Settings	Factory Settings
20H	Password 2		5AH	-
21H			0FH	-
22H	Interface selection	0: Auto, 1: Parallel 2: Serial	00H	00H*2
23H	Interface wait time	0 to 255 (by second)	0AH	0AH
24H	Parallel I/F speed	0: High speed 1: Normal	00H	00H
25H	Stylus Color 440 Reserved		00H	-
	Stylus Color 640 Font	0: Couier	00H	00H
26H	Stylus Color 440 Reserved		00H	-
	Stylus Color 640 Pitch	0: 10 cpi	00H	00H
27H	Stylus Color 440 Print direction control	0: Bi-D 1: Uni-D 2: Auto	02H	02H
	Stylus Color 640 Print direction control	2: Auto	02H	02H
28H	Stylus Color 440 CG table	0: PC437 1: PC850	00H	(*1)
	Stylus Color 640 CG table	0: PC437 1: PC850	08H	00H
29H	Reserved		00H	-
2AH	Auto LF/Network I/F mode	bit1: Network I/F mode (0=off, 1=on)  bit0: Auto line feed (0=off, 1=on)	00H	00H

Table A-23.

Stylus Color 440/640 EEPROM Address Map (Continued)

Address	Explanation	Setting	QPIT Settings	Factory Settings
2BH	Panel mask function	bit7: Enable Self Test bit6: Enable Hex Dump bit5: Extended settings bit2: Cleaning bit1: Replace I/C bit0: Load/Eject	00H	00H (*3)
2CH		Reserved	00H	-
2DH		Reserved	00H	-
2EH		Reserved	00H	-
2FH	Reserved		00H	-
30H	Password 3		5AH	-
31H			0FH	-
32H	Reserved		00H	-
33H	Reserved		00H	-
34H	Top margin	42 to 44X360 (by 1/360 inch)	78H	78H (*3)
35H			00H	00H (*3) NOTE
36H	Stylus Color 440 Reserved		00H	-
37H	Stylus Color 640 Bottom margin	1244 to 44x360 (by 1/360 inch)	36H=F0H 37H=1EH	36H=F0H 37H=1EH
38H	Stylus Color 440 Reserved		00H	-
39H	Stylus Color 640 Page length	1244 to 44x360 (by 1/360 inch)	38H=F0H 39H=1EH	38H=F0H 39H=1EH
3AH	Reserved		00H	-
3BH	Reserved		00H	-
3CH	Reserved		00H	-
3DH	Reserved		00H	-

NOTE: The reference \*3 for the address 35H only applies to Stylus Color 440.

Table A-24.

Stylus Color 440/640 EEPROM Address Map (Continued)

Address	Explanation	Setting	QPIT Settings	Factory Settings
3EH	CR-phase of Home		00H	00H
3FH	ERROR Number		00H	00H
40H	Password 4		5AH	-
41H			0FH	-
42H	Ink flags	bit7: Reserved bit6: black "one time" bit5: color "one time" bit4: Initial fill required bit3: Reserved bit2: in cleaning seq. bit1: black CL required bit0: color CL required	00H	10H
43H	Ink flags 2	bit2: YMC cartridge changed and cleaned 0: first cartridge 1: changed bit1: Black cartridge changed and cleaned 0: first cartridge 1: changed bit0: Black cartridge changed and cleaned 0: with YMC cartridge 1: alone	00H	00H
44H	Ink Counter Cb(total) 1count=100(ng)		00H	00H
45H			00H	00H
46H			00H	00H
47H			00H	00H

Table A-25.

Stylus Color 440/640 EEPROM Address Map (Continued)

Address	Explanation	Setting	QPIT Settings	Factory Settings
48H	Ink counter CY(total) 1count=100(ng)		00H	00H
49H			00H	00H
4AH			00H	00H
4BH			00H	00H
4CH	Ink counter Cm (total) 1count=100(ng)		00H	00H
4DH			00H	00H
4EH			00H	00H
4FH			00H	00H
50H	Password 5		5AH	-
51H			0FH	-
52H	Ink counter Cc(total) 1count=100(ng)		00H	00H
53H			00H	00H
54H			00H	00H
55H			00H	00H
56H	Ink counter Csm (total) 1count=100(ng)		00H	00H
57H			00H	00H
58H			00H	00H
59H			00H	00H
5AH	Ink counter Custodial 1count=100(ng)		00H	00H
5BH			00H	00H
5CH			00H	00H
5DH			00H	00H
5EH	Reserved		00H	-
5FH	Reserved		00H	-
60H	Password 6		5AH	-
61H			0FH	-
62H	Ink counter Rb		00H	00H
63H			00H	00H
64H	Ink counter Ry		00H	00H
65H			00H	00H

**Table A-26.**  
**Stylus Color 440/640 EEPROM Address Map (Continued)**

Address	Explanation	Setting	QPIT Settings	Factory Settings
66H	Ink counter A		00H	00H*2
67H			00H	00H*2
68H	power off time		00H	00H*2
69H			00H	00H*2
6AH	CL time		00H	00H*2
6BH			00H	00H*2
6CH	accumulated printing time	0: 0 minute	00H	00H
6DH		1: 15 minutes	00H	00H
		2: 30 minutes		
		3: 60 minutes		
		4: 90 minutes		
5: 120 minutes				
6EH	Stylus Color 440 Dot size for Economy mode	0: Normal x2 dot 1: Normal x1 dot	00H	00H (*4)
	Stylus Color 640 Reserved		00H	-
6FH	Reserved		00H	-
70H	Password 7		5AH	-
71H			0FH	-
72H to 79H, 7AH to 7FH	customized model name	string of counter strings of model field for Device ID	00H	00H

**Notes:**

\*\* Change model name of IEEE1284 device ID

\*1. Adjusted at factory.

\*2. Initialized after panel initialization is performed.

\*3. 01H is a factory setting for pacific market. (This note for the address 35H is only applicable for the Stylus Color 440.)

\*4. This function uses in the case that Raster graphics of 180 x 180 dpi (It is "economy" binding in a driver.) is printed and specifies the size of a dot. An ink life can be improved, by making this binding a normal x 1 dot, although an ordinariness prints it with normal x2 dot. Yet, the printing result becomes pale even since before. This function is implemented in the firmware subsequent to version Kaxxxx. Refer to the tables below.

**Table A-27. Economy Mode Specifications**

	Normal x2 dot	Normal x1 dot
Ink life	the same as before	improved
color	the same as before	becomes pale

**Table A-28. EEPROM Value and Dot Size**

Value of EEPROM (6EH)	Dot Size
00H	Normal x2 dot
01H	Normal x1 dot

## A.2.2 EEPROM Address Map (Stylus Color 740)

This section provides EEPROM address map for the Stylus Color 740.



**EEPROM map in this section only applies to Stylus Color 740.**



**If you need EEPROM map for Stylus Color 440/640, return to Section A.2.1. (They are combined in one table.)**

**Table A-29. Stylus Color 740 EEPROM Address Map**

Address	Explanation	Setting	QPIT Settings	Factory Settings
00H	Password 0		0FH	-
01H			5AH	-
02H	EEPROM mapping revision		41H	-
03H	Board ID	0: On-board RAM is 8 Mbit 1: On-board RAM is 16 Mbit	00H	(*1)
04H	CG	0: STD, 1: NLSP	00H	(*1)
05H	Market ID	0: Standard (World) 2: Custom	00H	(*1)
06H	Custom EEPROM sub number		00H	00H
07H			00H	00H
08H			00H	00H
09H			00H	00H
0AH	Head actuator rank ID for VhN		00H	(*1)
0BH	Head actuator rank ID for Vhμ		00H	(*1)
0CH	Head actuator rank ID for VhL		00H	(*1)
0DH	Head actuator rank ID for AR		00H	(*1)
0EH	Head rank MW-ID		00H	(*1)
0FH	Reserved for Head-ID		00H	-
10H	Reserved for Head-ID		00H	-
11H	Reserved for Head-ID		00H	-
12H	Head actuator rank ID for lwAB		00H	(*1)
13H	Head actuator rank ID for lwCD		00H	(*1)

Table A-30. Stylus Color 740 EEPROM Address Map (Continued)

Address	Explanation	Setting	QPIT Settings	Factory Settings
14H	Head actuator rank ID for lWEF		00H	(*1)
15H	Bi-D Adjustment data for Normal-dot	-36<=n<=+36 (by 1/1440 inch)	00H	(*1)
16H	Bi-D Adjustment data for Micro-dot	-36<=n<=+36 (by 1/1440 inch)	00H	(*1)
17H	Bi-D Adjustment data for Variable-dot	-36<=n<=+36 (by 1/1440 inch)	00H	(*1)
18H	Uni-D adjustment data	-36<=n<=+36 (by 1/1440 inch)	00H	(*1)
19H	Reserved for adjustment data		00H	-
1AH	Reserved for adjustment data.		00H	-
1BH	1st dot position adjustment data	-40<=n<=+40 (by 1/1440 inch)	00H	(*1)
1CH	Carriage speed adjustment data	-4<=n<=+4 (by G.A. timer unit)	00H	(*1)
1DH	Carriage phase on Home		00H	-
1EH	Paper sensor adjustment data	-127<=n<=+127 (by 1/720 inch)	00H	(*1)
1FH	ERROR Code		00H	00H
20H	CPSI password		00H	00H
21H			00H	00H
22H			00H	00H
23H			00H	00H
24H	CPSI license flag	0: disable 1: enable	00H	00H
25H	CPSI font license	0: disable 1: enable	00H	00H
26H	Interface selection	0: Auto, 1: Parallel 2: Serial, 3: USB	00H	00H (*2)

Table A-31. Stylus Color 740 EEPROM Address Map (Continued)

Address	Explanation	Setting	QPIT Settings	Factory Settings
27H	Interface time-out	0 to 255 (by second, value of 0 means 10 seconds)	0AH	0AH
28H	Compatibility speed	0: Fast, 1: Slow 2: Special-1, 3: Special-2	00H	00H
29H	ECP speed *3	0: Fast, 1: Slow	00H	00H
2AH			00H	00H
2BH	I/F Control flags	bit 1: ECP mode (0=Off, 1=On) *4 bit 0: IEEE1284 mode (0=On, 1=Off) *5	00H	00H
2CH			00H	01H
2DH	Reserved for USB		00H	-
2EH	Reserved for USB		00H	-
2FH	Reserved for USB		00H	-
30H	Font	0: Roman, 1: Sans Serif 2: Courier, 3: Prestige 4: Script, 10: Roman T 11: Sans Serif, 7: Draft	00H	02H
31H	Pitch	0: 10 cpi, 1: 12 cpi 2: 15 cpi, 3: 17 cpi 4: 20 cpi, 5: Proportional	00H	00H
32H	Print direction control	0: Bi-D 1: Uni-D 2: Auto	02H	02H

\*3: BUSY signal delay time from fall-edge of a -STB signal.

(Fast: Maximum 1MB/s, Slow: Maximum 600KB/s)

\*4: Select IEEE1284 transfer mode. (ECP or Nibble)

\*5: Enable or disable reverse transfer. (When disabled, ignore -SLIN signal)

Table A-32. Stylus Color 740 EEPROM Address Map (Continued)

Address	Explanation	Setting	QPIT Settings	Factory Settings
33H	CG table	0: Italic U.S.A., 1: Italic France, 2: Italic Germany 3: Italic U.K, 4: Italic Denmark, 5: Italic Sweden, 6: Italic Italy, 7: Italic Spain, 8: PC437, 9: PC437 Greek, 10: PC850, 11: PC860, 12: PC863, 13: PC865, 14: PC861, 15: BRASCII, 16: Abicomp, 17: Roman 8, 18: ISO Latin1, 19: PC853, 20: PC855, 21: PC852, 22: PC857, 23: PC866, 24: PC869, 25: MAZOWIA, 26: Code MJK, 27: ISO8859-7, 28: ISO Latin 1T, 29: Bulgaria, 30: PC774, 31: Estonia, 32: ISO 8859-2, 33: PC 866 LAT, 34: PC 866 UKR, 35: PC AR864, 36: PC APTEC, 37: PC 708, 38: PC720, 39: Hebrew7, 40: Hebrew8, 41: PC862	08H	08H
34H	Auto LF, Network I/F mode	bit1: Network I/F mode (0=Off, 1=On), bit0: Auto line feed (0=Off, 1=On)	00H	00H
35H	Panel mask function	bit 7: Entry Self-Test bit 6: Entry Hex-Dump bit 5: Extended settings bit 4: Reserved bit 3: Reserved bit 2: Cleaning bit 1: Replace I/C bit 0: Load/Eject	00H	00H
36H	Top margin	42 to 44x360 (by 1/360 inch)	00H	00H
37H			78H	78H

Table A-33. Stylus Color 740 EEPROM Address Map (Continued)

Address	Explanation	Setting	QPIT Settings	Factory Settings
38H	Bottom margin	1244 to 44x360 (by 1/360 inch)	IEH	IEH
39H			F0H	F0H
3AH	Page length	1244 to 44x360 (by 1/360 inch)	IEH	IEH
3BH			F0H	F0H
3CH	Reserved for main		00H	-
3DH	Reserved for main		00H	-
3EH	Reserved for main		00H	-
3FH	Reserved for main		00H	-
40H	Password 1		0FH	-
41H			5AH	-
42H	Ink flag 1	bit 7: Reserved bit 6: black one-time bit 5: color one-time bit 4: Initial fill required bit 3: Reserved bit 2: ink cleaning seq. Bit 1: black CL required bit 0: color CL required	00H	00H
43H	Ink flag 2	bit 2: YMC cartridge changed and cleaned bit 1: Black cartridge changed and cleaned bit 0: Black cartridge changed and cleaned	00H	00H
44H	Ink counter Cb		00H	00H
45H			00H	00H
46H			00H	00H
47H			00H	00H
48H	Ink counter Cy		00H	00H
49H			00H	00H
4AH			00H	00H
4BH			00H	00H



Table A-34. Stylus Color 740 EEPROM Address Map (Continued)

Address	Explanation	Setting	QPIT Settings	Factory Settings
4CH	Ink counter Cm		00H	00H
4DH			00H	00H
4EH			00H	00H
4FH			00H	00H
50H	Ink counter Cc		00H	00H
51H			00H	00H
52H			00H	00H
53H			00H	00H
54H	Ink counter Clm		00H	00H
55H			00H	00H
56H			00H	00H
57H			00H	00H
58H	Ink counter Clc		00H	00H
59H			00H	00H
5AH			00H	00H
5BH			00H	00H
5CH	Ink counter Rb		00H	00H
5DH			00H	00H
5EH	Ink counter Ry		00H	00H
5FH			00H	00H
60H	Ink counter A		00H	00H(*2)
61H			00H	00H(*2)
62H	Power off time		00H	00H(*2)
63H			00H	00H(*2)
64H	CL time		00H	00H(*2)
65H			00H	00H(*2)
66H	accumulated printing time		00H	00H
67H			00H	00H
68H	Reserved for ink system		00H	-
69H	Reserved for ink system		00H	-

Table A-35. Stylus Color 740 EEPROM Address Map (Continued)

Address	Explanation	Setting	QPIT Settings	Factory Settings
6AH	Printer-ID Strings [22]		00H	00H
6BH			00H	00H
6CH			00H	00H
6DH			00H	00H
6EH			00H	00H
6FH			00H	00H
70H			00H	00H
71H			00H	00H
72H			00H	00H
73H			00H	00H
74H			00H	00H
75H			00H	00H
76H			00H	00H
77H			00H	00H
78H			00H	00H
79H			00H	00H
7AH			00H	00H
7BH			00H	00H
7CH			00H	00H
7DH			00H	00H
7EH	00H	00H		
7FH	00H	00H		

\*1: Adjusted at factory

\*2: Initialized after panel initialization of EEPROM is performed.

\*3: BUSY signal delay time from fall-edge of a -STB signal.

(Fast: Maximum 1MB/s, Slow: Maximum 600KB/s)

\*4: Select IEEE1284 transfer mode. (ECP or Nibble)

\*5: Enable or disable reverse transfer. (When disabled, ignore -SLIN signal)

## A.3 Circuit Board Component Layouts

---

This section is composed of the following components layouts.

- ➔ C206MAIN-B (Stylus Color 440)
- ➔ C256MAIN (Stylus Color 640)
- ➔ C257MAIN (Stylus Color 740)
- ➔ C206PSB/PSE (Stylus Color 440/640)
- ➔ C257PSB/PSE (Stylus Color 740)
- ➔ C206PNL (Stylus Color 440/640)
- ➔ C209PNL (Stylus Color 740)

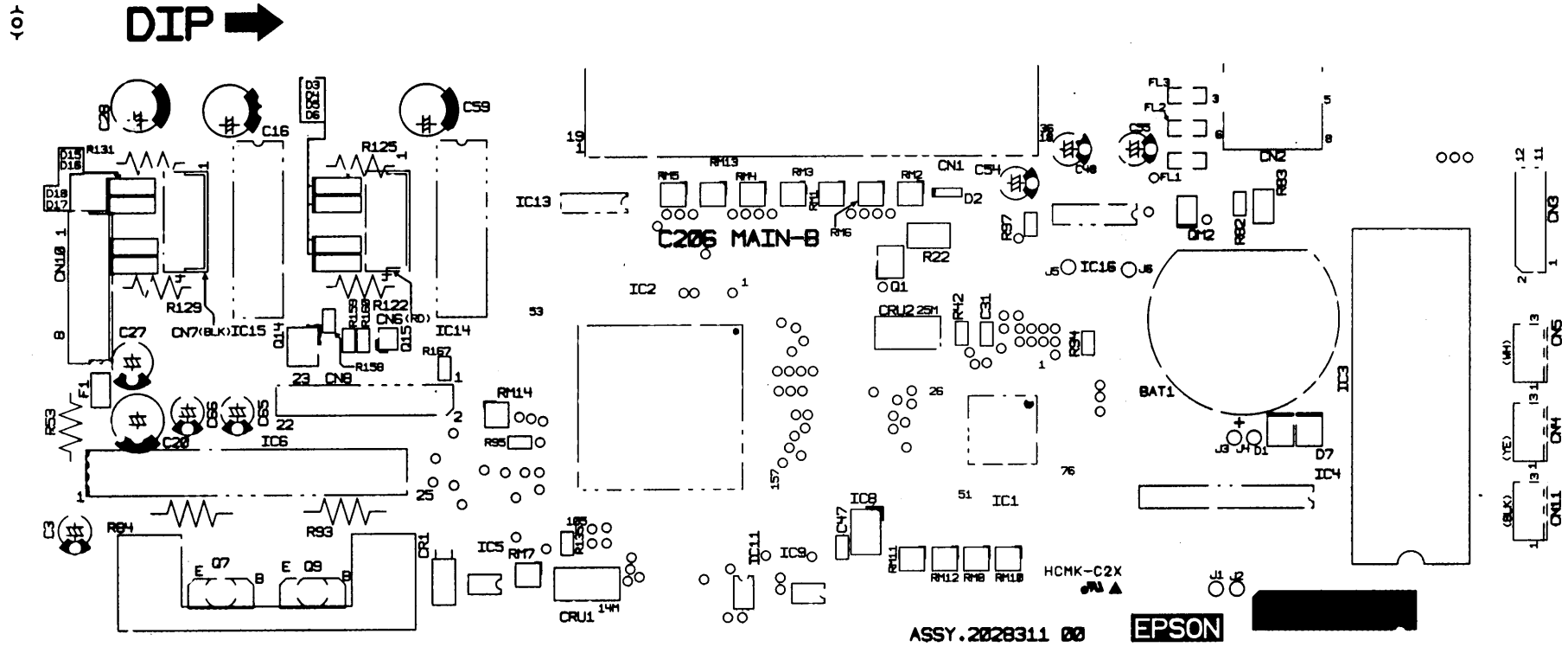

Figure A-3. C206MAIN-B Board Component Layout (1/2) (Stylus Color 440)



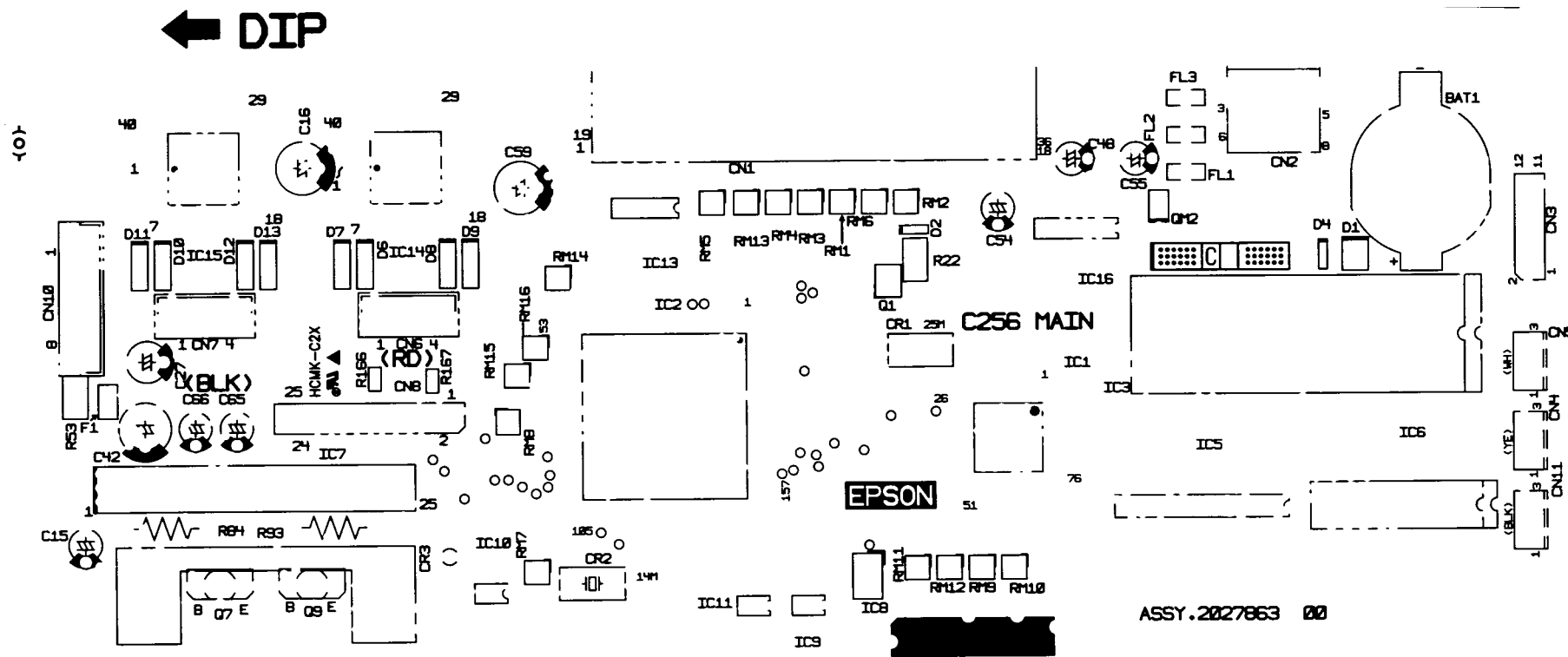

Figure A-5. C256MAIN Board Component Layout (1/2) (Stylus Color 640)

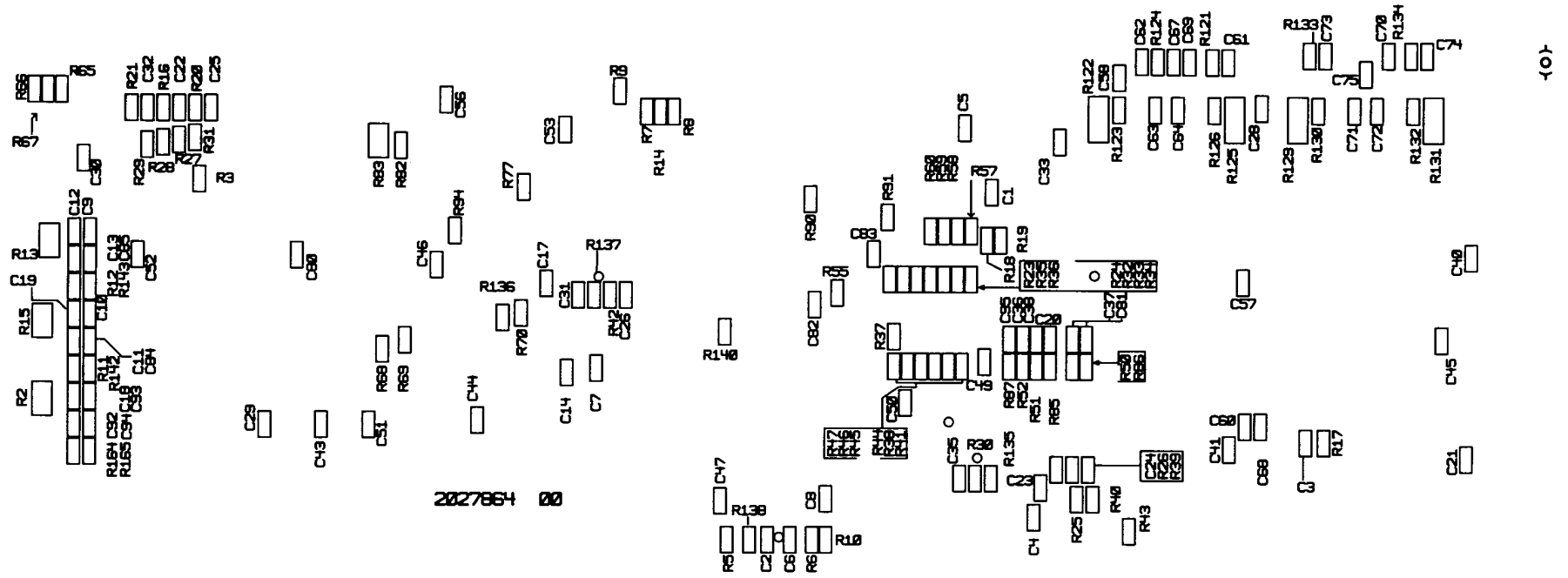

Figure A-6. C256MAIN Board Component Layout (2/2) (Stylus Color 640)

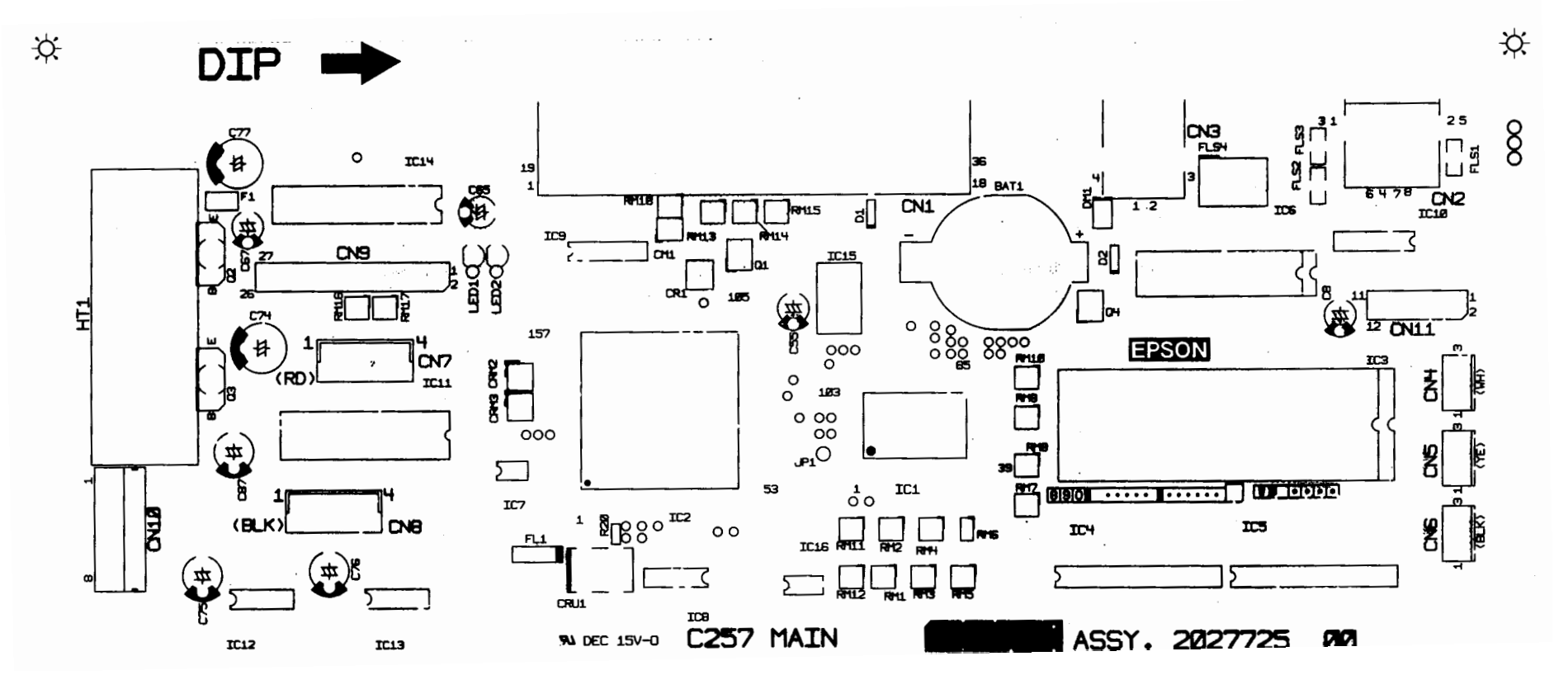

Figure A-7. C257MAIN Board Component Layout (1/2) (Stylus Color 740)

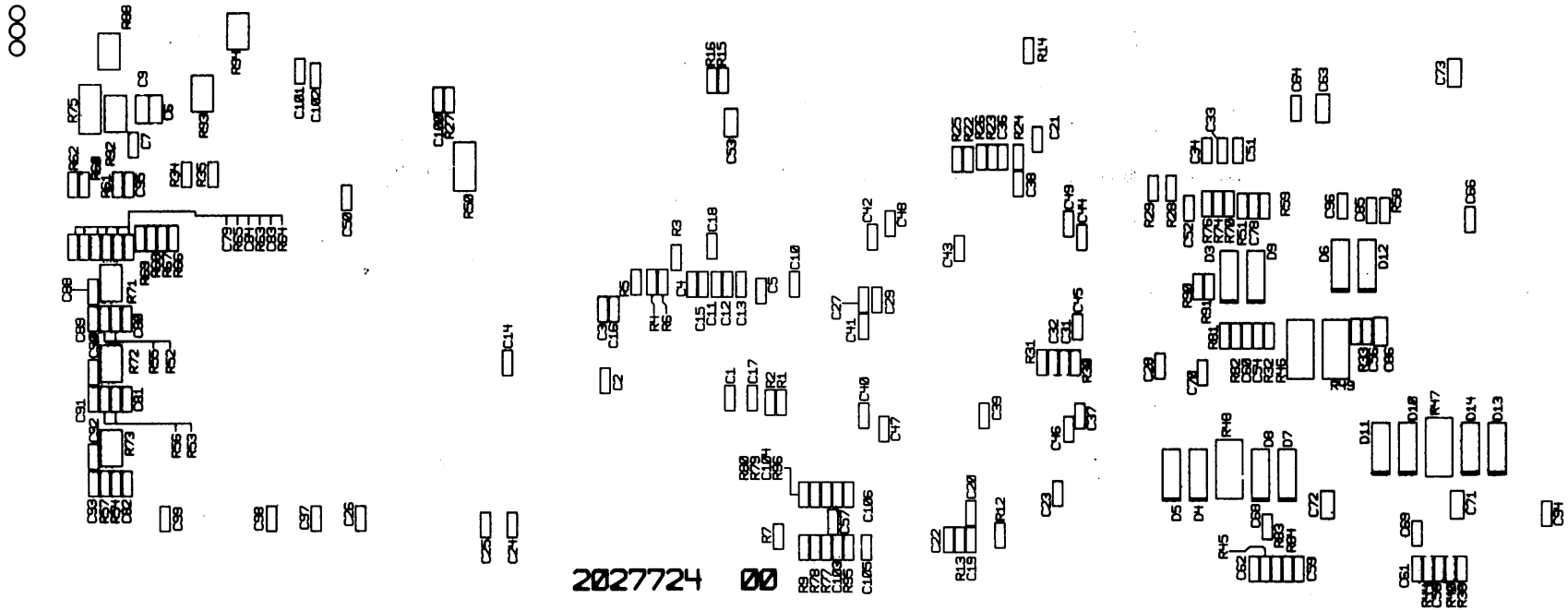

Figure A-8. C257MAIN Board Component Layout (2/2) (Stylus Color 740)



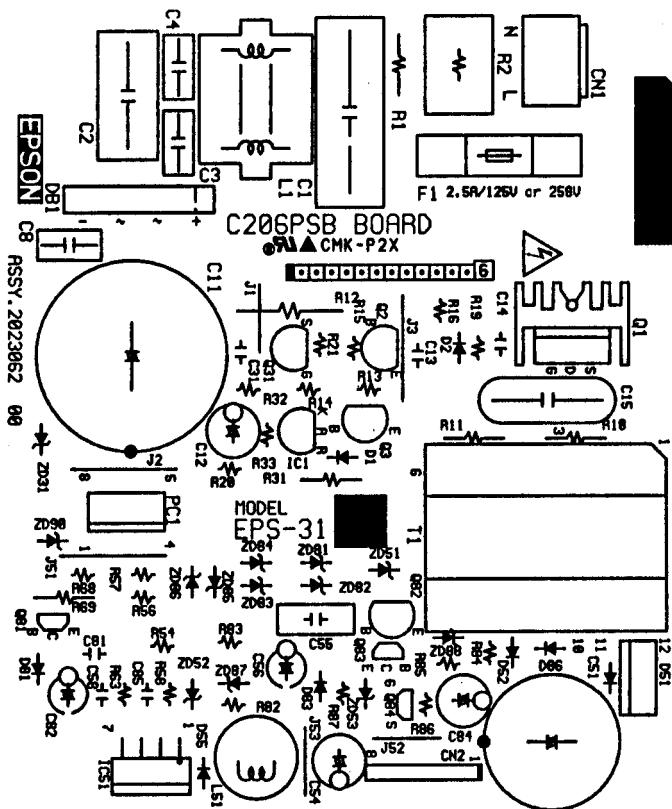

Figure A-9.  
C206PSB Board Component Layout (Stylus Color 440/640)

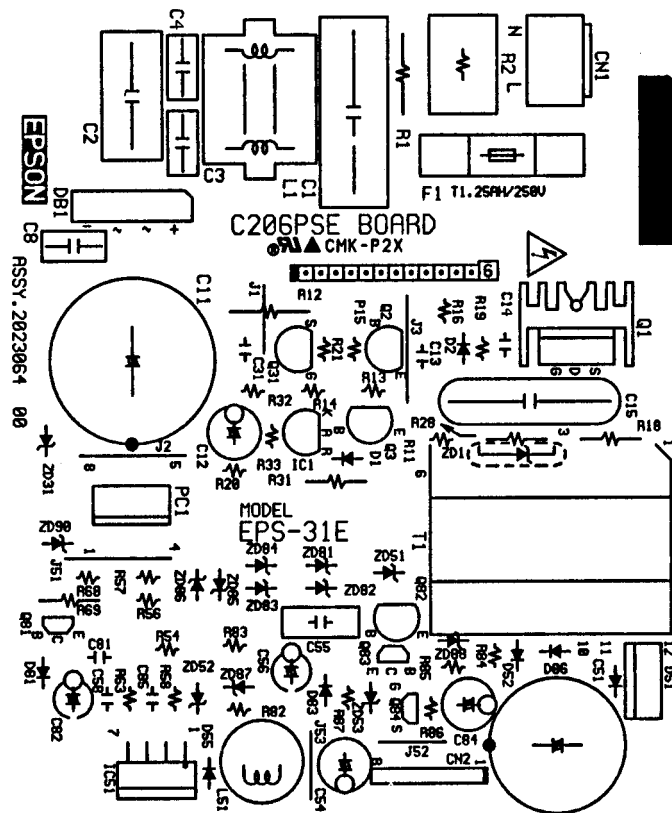

Figure A-10.  
C206PSE Board Component Layout (Stylus Color 440/640)

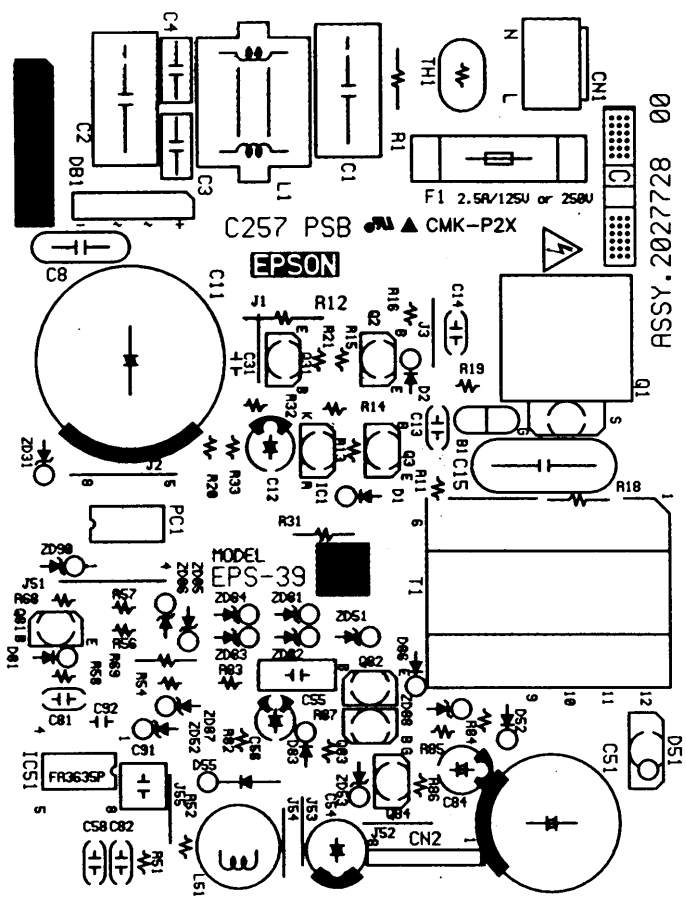

Figure A-11.

C257 PSB Board Component Layout (Stylus Color 740)

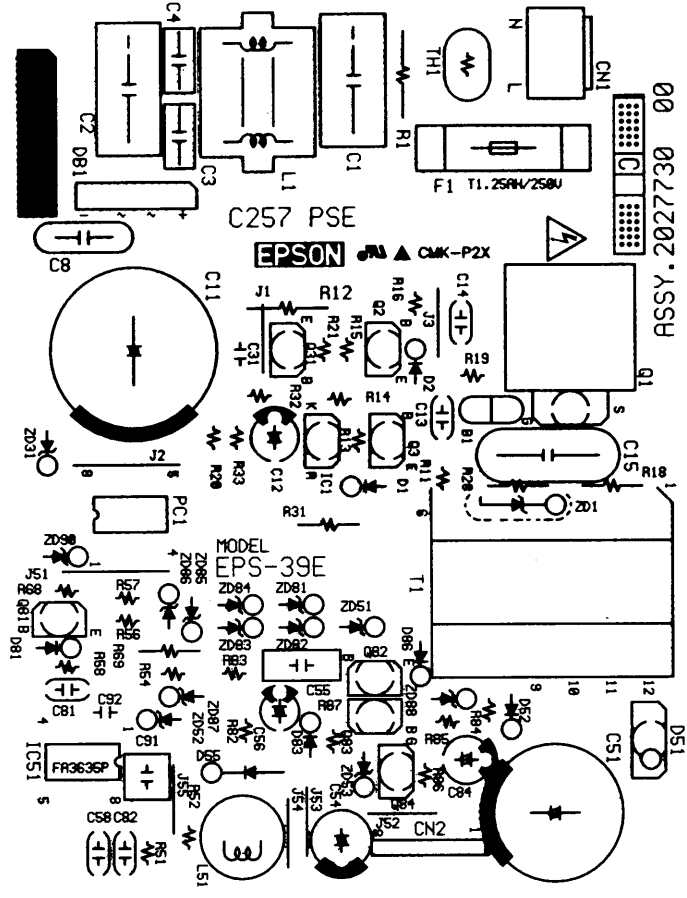

Figure A-12.

C257 PSE Board Component Layout (Stylus Color 740)

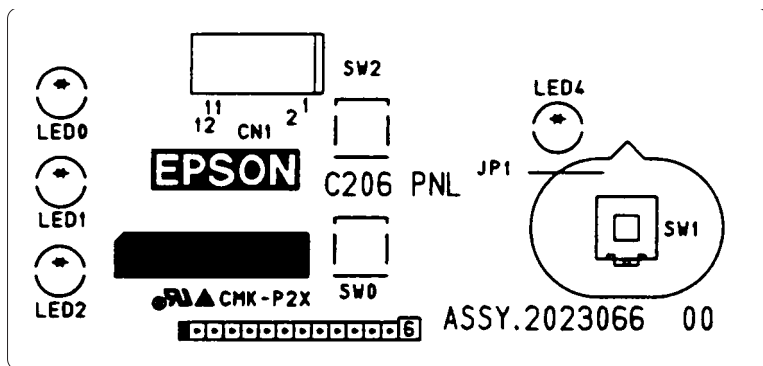

Figure A-13. C206PNL Component Layout

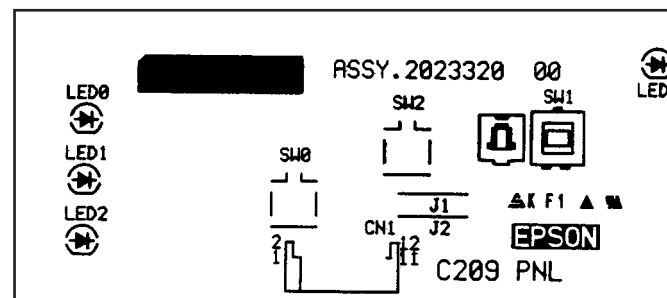

Figure A-14. C209PNL Component Layout

## A.4 Exploded Diagrams

---

This section contains the following exploded diagrams.

 Exploded diagram for Stylus Color 440 (1/3, 2/3, 3/3)

 Exploded diagram for Stylus Color 640 (1/3, 2/3, 3/3)

 Exploded diagram for Stylus Color 740 (1/3, 2/3, 3/3)

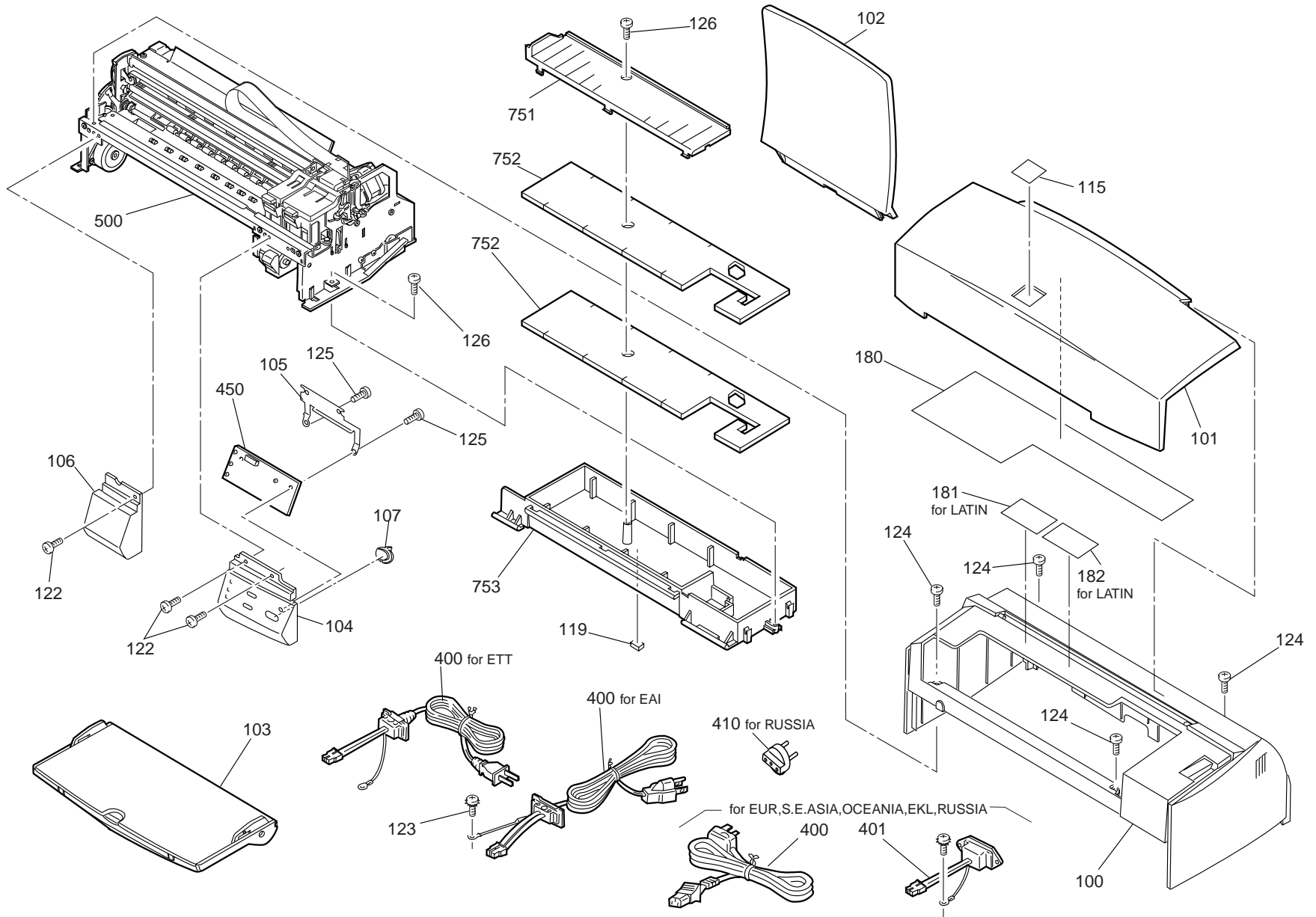

EXPLODED DIAGRAM FOR EPSON STYLUS COLOR 440 (1/3) REV.1.0

10001

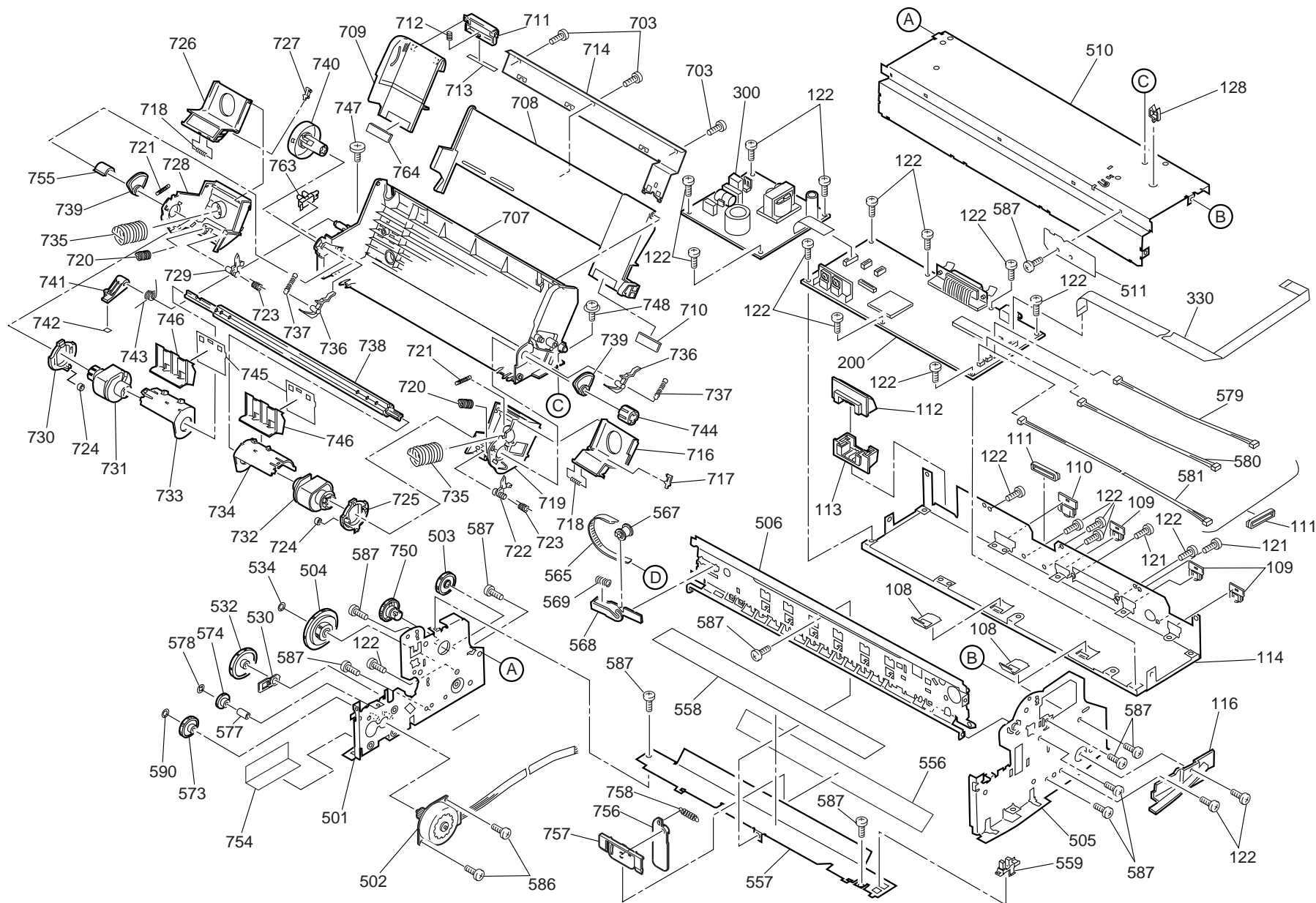

EXPLODED DIAGRAM FOR EPSON STYLUS COLOR 440 (2/3) REV.1.0

10001



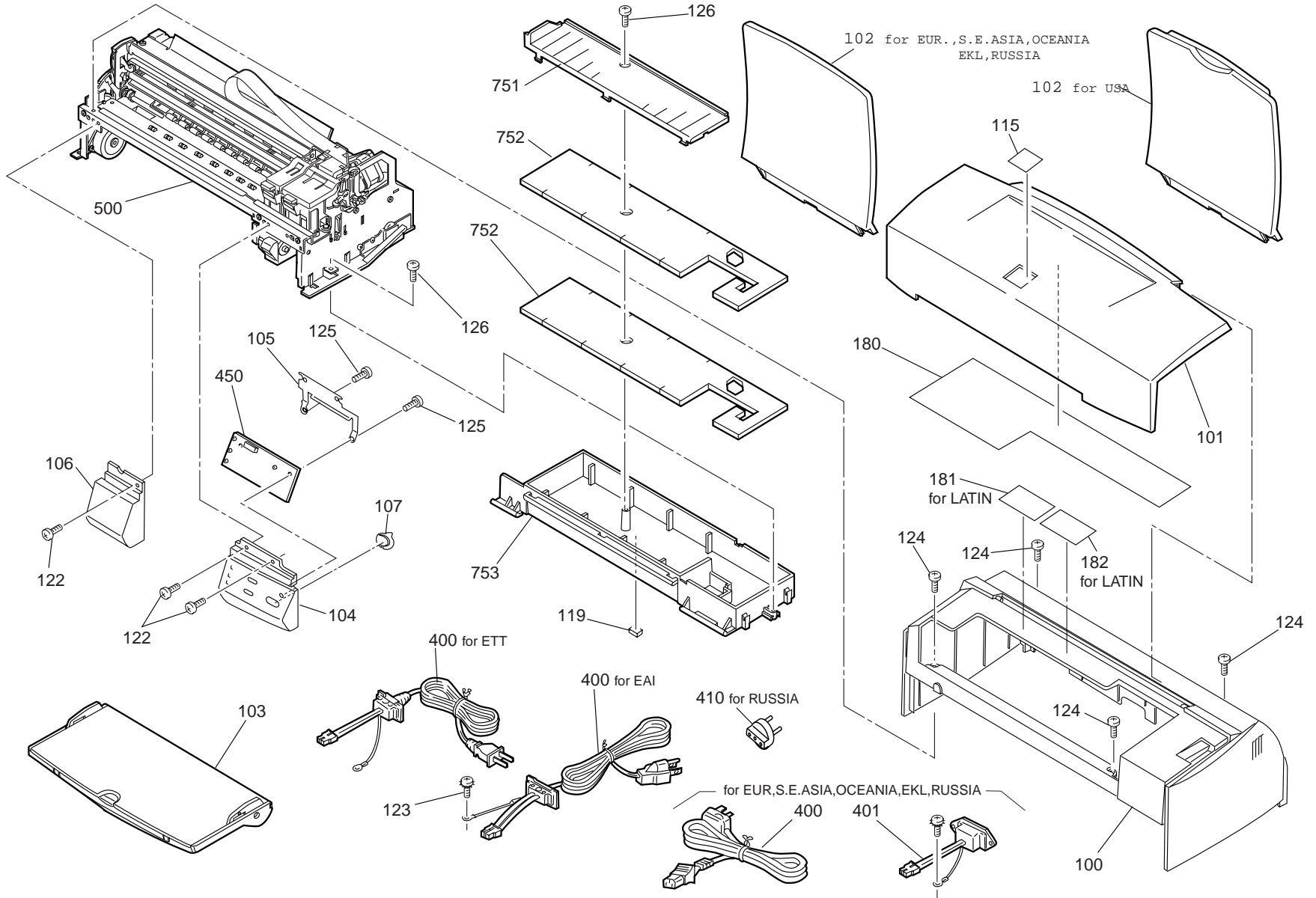

EXPLODED DIAGRAM FOR EPSON STYLUS COLOR 640 (1/3) REV.1.0 10002



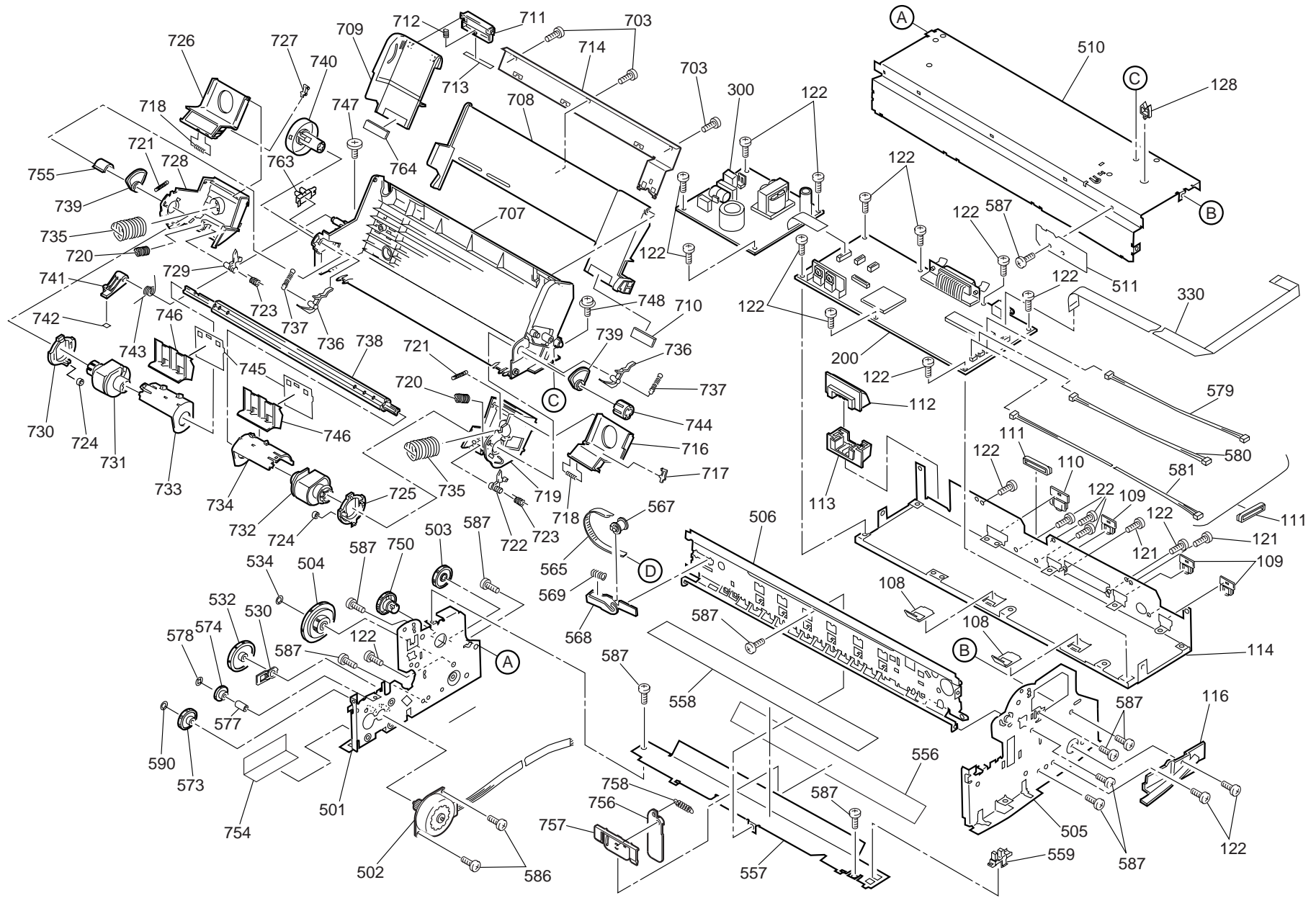

EXPLODED DIAGRAM FOR EPSON STYLUS COLOR 640 (2/3) REV.1.0 10002

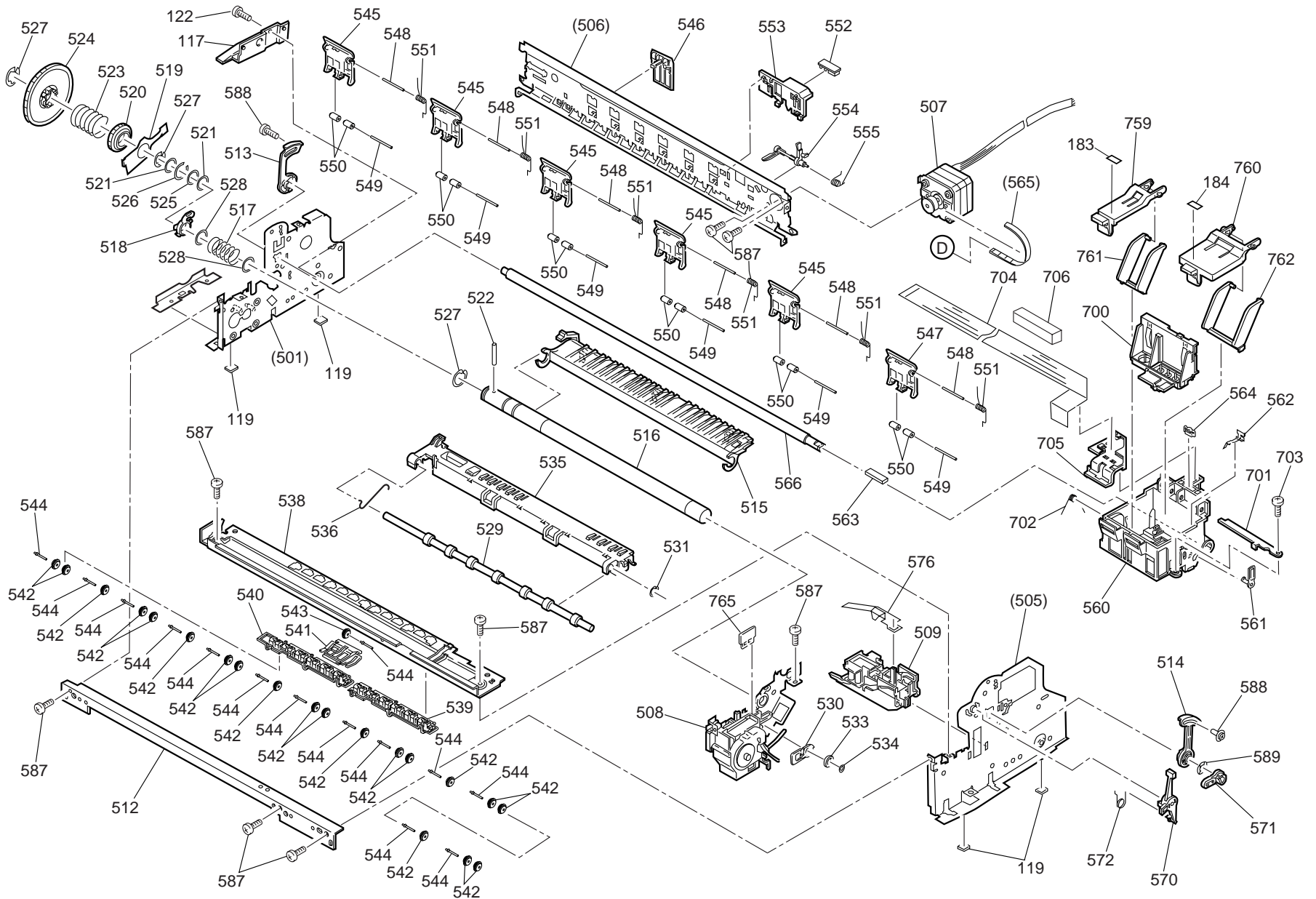

EXPLODED DIAGRAM FOR EPSON STYLUS COLOR 640 (3/3) REV.1.0

10002

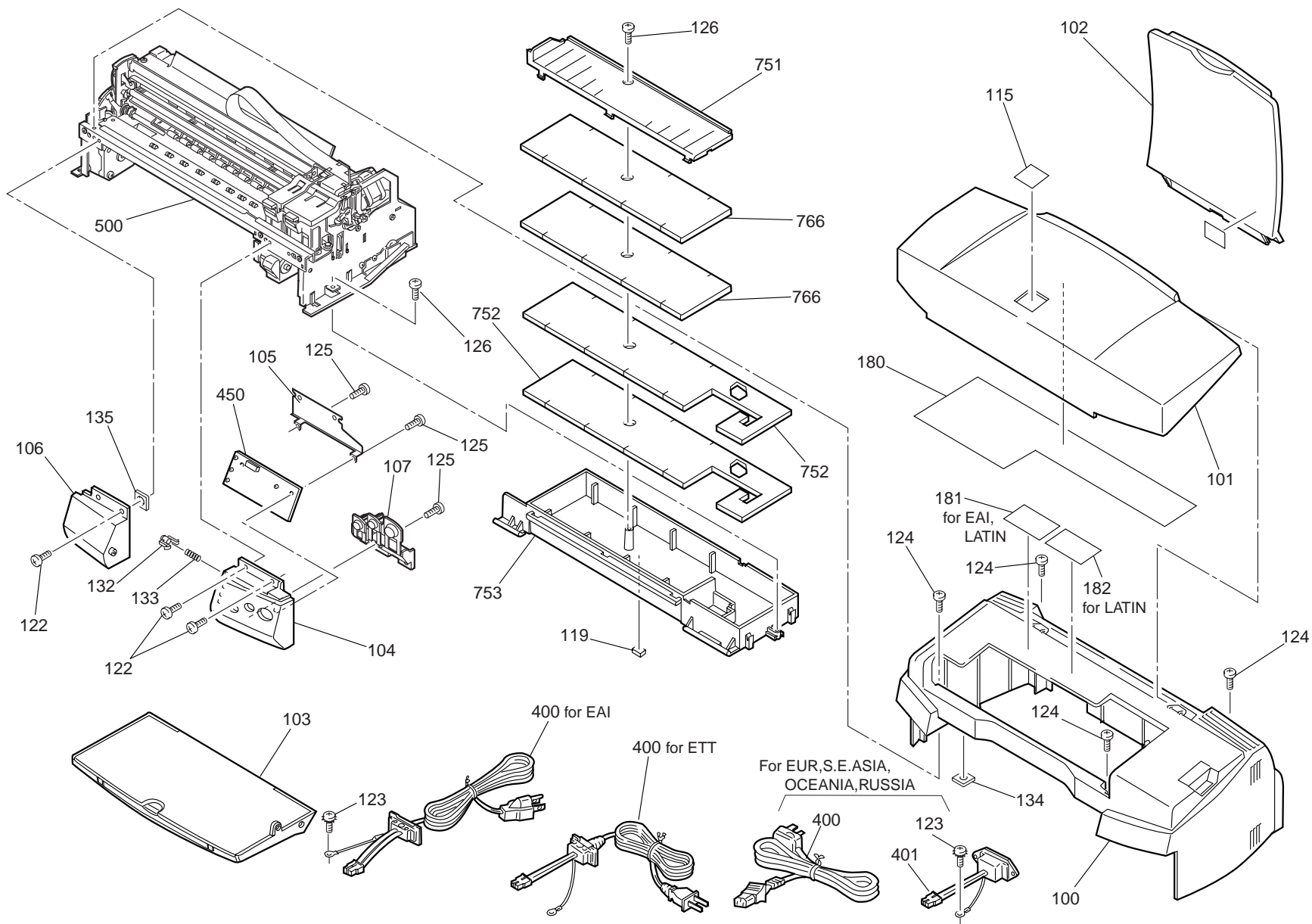

EXPLODED DIAGRAM FOR EPSON STYLUS COLOR 740 (1/3)

Rev.01 10004

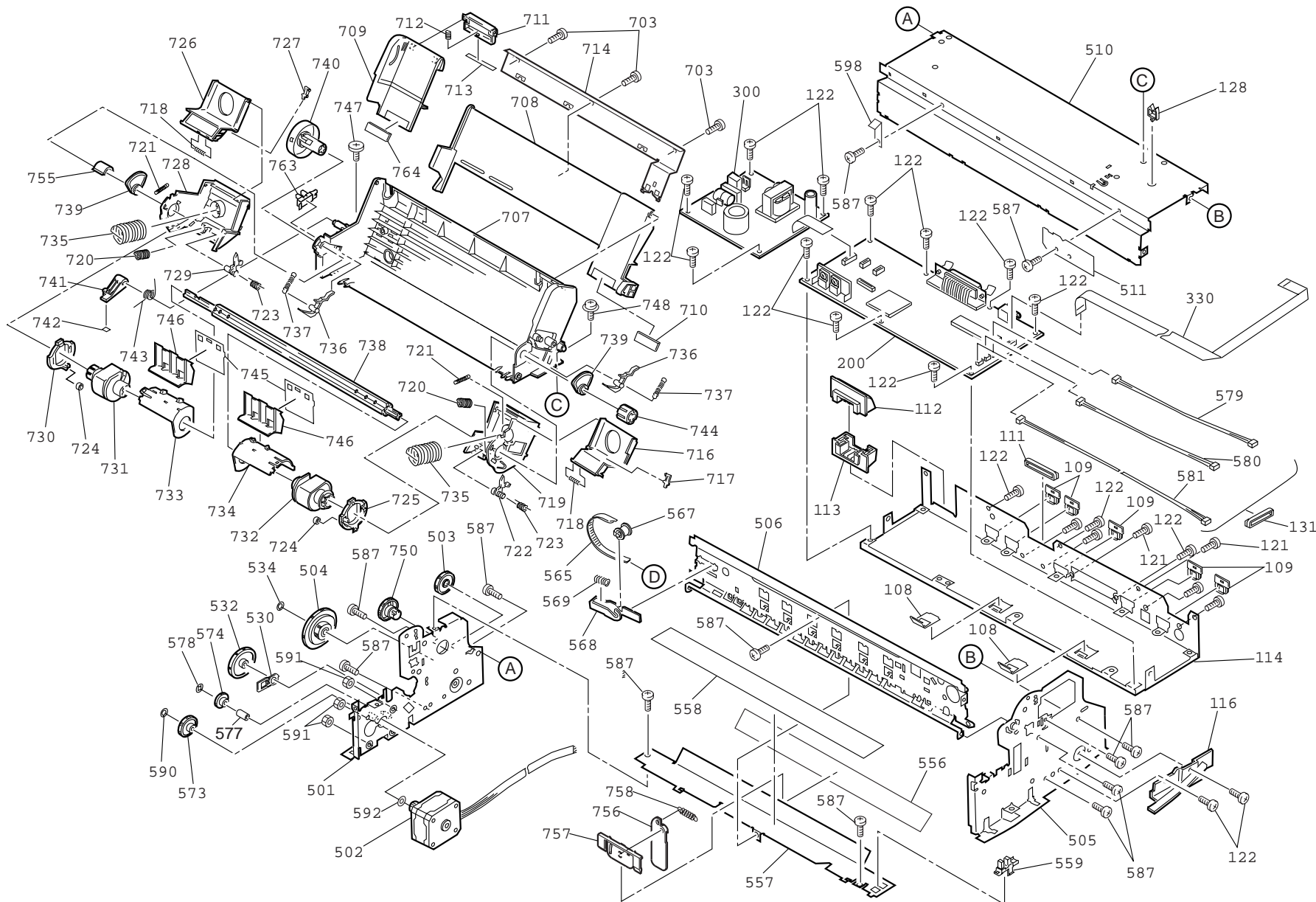

EXPLODED DIAGRAM FOR EPSON STYLUS COLOR 740 (2/3)

Rev.01 10004

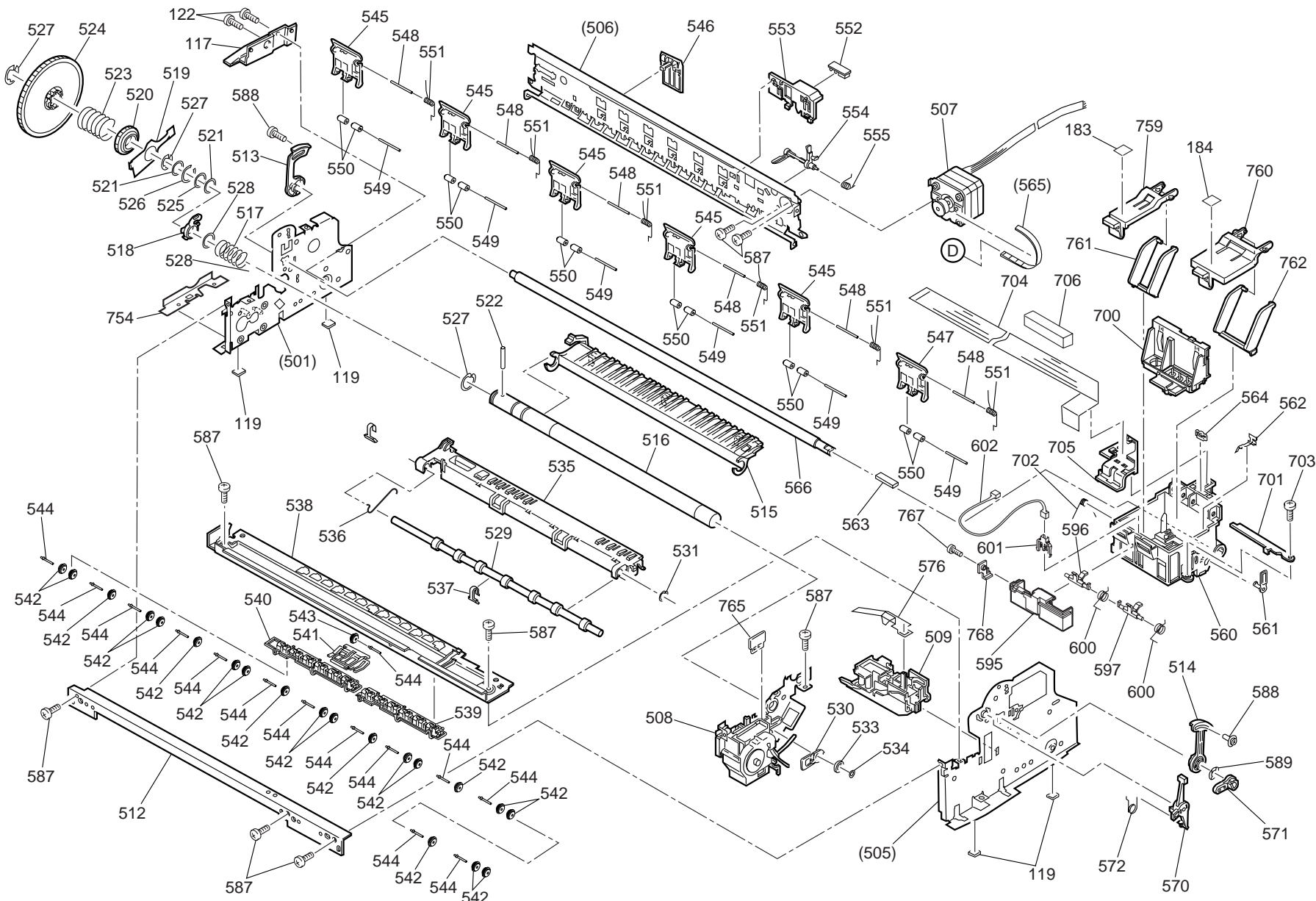

EXPLODED DIAGRAM FOR EPSON STYLUS COLOR 740 (3/3)

Rev.01 10004



## A.5 Part List

### A.5.1 Part List for Stylus Color 440/640

Table A-36. Part List for Stylus Color 440/640 (1/4)

Part Name		Part Name	
100	Housing;B	128	Mini Clamp
101	Cover, Printer;B	180	Label, Caution 1;B
102	Paper Support;B	181	Label, Accessory B
103	Stacker Assembly;B	182	Label, Accessry C
104	Panel Assembly, Right;B	183	Label, Lever Cartridge, Black
105	Shield Plate, Panel	184	Label, Lever Cartridge, Color
106	Housing, Panel, Left;B	200	Board Assembly, Main
107	Button, P/S;B	300	Board Assembly, Power Supply
108	Groundign Plate	330	Harness
109	Cover, Shield Plate, M/B, Right	400	Power Cable Assembly
110	Cover, Shield Plate, M/B, Left	450	Board Assembly, Panel
111	Cover, Cable	500	Printer Mechanism
112	Cover, Inlet, Upper;B	501	Frame Assembly, Left
113	Cover, Inlet, Lower;B	502	Motor Assembly, PF
114	Shiled Plate, M/B;C	503	Spur Gear, 23.2
115	Logo Plate	504	Combination Gear, 16, 40.8
116	Housing, Sub, Right;B	505	Frame, Right
117	Housing Sub, Left;B	506	Frame, Top
119	Foot	507	Motor Assembly, CR
121	CP Screw, M3x6	508	Pump Assembly
122	CBS-Tite Screw, M3x6	509	Cap Assembly
123	CB(O) Screw, 4x5, F/Zg	510	Frame, Bottom
124	CBS-Tite Screw, M3x10	511	Sheet, Protection, Head
125	CBP-Tite Screw, M3x8, F/Zn	512	Frame, Front
126	CBP-Tite Screw, M3x10, F/Zn	513	Bushing, Parallelism Adjustment, Left

Table A-37. Part List for Stylus Color 440/640 (2/4)

Part Name		Part Name	
514	Bushing, Parallelism Adjustment, Right	546	Paper Guide, Right
515	Paper Guide, Rear	547	Paper Guide, Left
516	Roller, PF	548	Shaft, Paper Guide, Upper
517	Compression Spring, 5.85	549	Shaft, Roller, Driven
518	Bushing, 12, Left	550	Roller, Driven;D
519	Lever, Change	551	Torsion Spring, 117.6
520	Spur Gear, 26.4	552	Board Assembly, PE
521	Spacer, C-ring	553	Holder, PE
522	Scallop Sp-AW, 2x16, F/B	554	Lever, PE
523	Compression Spring, 0.9	555	Torsion Spring, 0.22
524	Spur Gear, 67.2	556	Sheet, Guide Plate, Cable
525	Spacer, Fixing, Roller, PF	557	Guide Plate, Cable
526	Spacer, Fixing, Roller, PF;B	558	Sheet, Cable
527	Crescent Ring	559	Detector, PE
528	Plain Washer12.2x0.5x15	560	Carriage Assembly
529	Roller Assembly, Paper Eject	561	Lever, Adjust
530	Bushing, 6	562	Grouding Plate, Head
531	Retaining Ring, Type-E(4)	563	Oil Pad
532	Spur Gear, 36	564	Slider, CR
533	Spur Gear, 11	565	Timing Belt
534	Plain Washer, 4.1x0.5x6.5	566	Shaft, CR, Guide
535	Paper Guide, Front	567	Pulley Assembly, Driven
536	Grounding Spring, Paper Eject	568	Holder, Pulley, Driven
538	Frame, Paper Eject	569	Compression Spring, 19.6
539	Holder, Star Wheel, Right	570	Lever, PG
540	Holder, Star Wheel, Left	571	Lever, PG, Sub
541	Holder, Star Wheel, Front	572	Torsion Spring, 63.7
542	Star Wheel Assembly, 8(Natural)	573	Combination Spring, 6, 34.4
543	Star Wheel 8;B	574	Combination Spring, 8, 30
544	Bar Spring, Star Wheel	576	Absorber, Slider, Cap
545	Paper Guide, Upper	577	Bushing, Fixing, Combination Gear

Table A-38. Part List for Stylus Color 440/640 (3/4)

Part Name			
578	Push Nut, 2	724	Roller, LD, Sub
579	Harness, HP	725	Holder, Roller, LD, Sub, Right
580	Harness, PE	726	Pad Assy., Left
581	Harness, ASF	727	Lever, Pad, Release, Left
586	CBS-Tite Screw	728	Holder, Edge Guide, Left
587	CBS-Tite Screw, M3x6	729	Lever, Paper Return, Left
588	CBS-Tite (P4) Screw, 3x6, F/Zn	730	Holder, Roller, LD, Sub, Left
589	Leaf Spring, 6.2x0.15x11	731	Roller Assy., LD, Left
590	Plain Washer, 2.6x0.5x8	732	Roller Assy., LD, Right
700	Printehead	733	Cover, Roller, LD, Left
701	Fastener, Head	734	Cover, Roller, LD, Right
702	Torsion Spring, 49	735	Compression Spring, 1.961
703	CBP-Tite Screw, 3x6, F/Zn	736	Lever, Fixing, Edge Guide;B
704	Cable, Head	737	Tension Spring, 0.088
705	Holder, Cable	738	Shaft, Roller, LD
706	Spacer, Cable Head	739	Lever, Hopper, Release
707	Frame, ASF;B	740	Wheel, Detection
708	Hopper	741	Lever, Brake
709	Edge Guide	742	Pad, Brake
710	Cork	743	Torsion Spring, 41.2
711	Slider, Edge Guide	744	Bushing, Fixing, Shaft
712	Compression Spring, 3.23	745	Sheet, Paper Feed
713	Pad, Brake, Edge Guide	746	Holder, Sheet, Paper Feed
714	Reinforcing Plate, Hopper	747	Shaft, Mouting, CR
716	Pad Assy., Right	748	CBS (P4) Screw, 3x6, F/Zn
717	Lever, Pad, Release, Right	750	Spur Gear, 34
718	Bar Spring, Holder, Pad	751	Paper Guide, Lower
719	Holder, Edge Guide, Right	752	Absorber, Waste Ink, Large
720	Compression Spring, 1.17	753	Tray, Absorber
721	Tension Spring, 0.62	754	Spacer, Tray
722	Lever, Paper Return, Right	755	Bushing, Fixing, Shaft, Left
723	Tension Spring, 0.294	756	Paper Support, Sub, Upper

Table A-39. Part List for Stylus Color 440/640 (4/4)

757	Holder, Paper Support, Sub, Upper		
758	Torsion Spring, 0.29		
759	Cover, Cartridge, Bk		
760	Cover, Cartridge, C;B		
761	Separator, Cartridge, Bk		
762	Separator, Cartridge, C		
763	Detector, HP		
764	Cork;B		
765	Cleaner, Head, ASP		

### A.5.2 Part List for Stylus Color 740

**Table A-40. Part List for Stylus Color 740 (1/4)**

100	Housing	135	Spacer, Housing, Panel
101	Cover, Printer	180	Label, Caution 1
102	Paper Support Assembly	181	Label, Accessory
103	Stacker Assembly	183	Label, Lever Cartridge, Black
104	Panel Assembly	184	Label, Lever Cartridge, Color
105	Shield Plate, Panel	200	Board Assembly, Main
106	Housing, Panel, Left	300	Board Assembly, Power Supply
107	Button, P/S;B	330	Harness
108	Groundign Plate	400	Power Cable Assembly
109	Cover, Shield Plate, M/B, Right	450	Board Assembly, Panel
111	Cover, Cable	500	Printer Mechanism
112	Cover, Inlet, Upper;B	501	Frame Assembly, Left
113	Cover, Inlet, Lower;B	502	Motor Assembly, PF
114	Shiled Plate, M/B	503	Spur Gear, 23.2
115	Logo Plate	504	Combination Gear, 16, 40.8
116	Housing, Sub, Right;B	505	Frame, Right
117	Housing Sub, Left;B	506	Frame, Top
119	Foot	507	Motor Assembly, CR
121	CP Screw, M3x6	508	Pump Assembly
122	CBS-Tite Screw, M3x6	509	Cap Assembly
123	CB(O) Screw, 4x5, F/Zg	510	Frame, Bottom
124	CBS-Tite Screw, M3x10	511	Sheet, Protection, Head
125	CBP-Tite Screw, M3x8, F/Zn	512	Frame, Front
126	CBP-Tite Screw, M3x10, F/Zn	513	Bushing, Parallelism Adjustment, Left
128	Mini Clamp	514	Bushing, Parallelism Adjustment, Right
131	Cover, Cable;B	515	Paper Guide, Rear
132	Lock, Stacker	516	Roller, PF
133	Compression Spring, 2.94	517	Compression Spring, 5.85
134	Spacer, Housing	518	Bushing, 12, Left

**Table A-41. Part List for Stylus Color 740 (2/4)**

519	Lever, Change	550	Roller, Driven;D
520	Spur Gear, 26.4	551	Torsion Spring, 117.6
521	Spacer, C-ring	552	Board Assembly, PE
522	Scallop Sp-AW, 2x16, F/B	553	Holder, PE
523	Compression Spring, 0.9	554	Lever, PE
524	Spur Gear, 73.6	555	Torsion Spring, 0.22
525	Spacer, Fixing, Roller, PF	556	Sheet, Guide Plate, Cable
526	Spacer, Fixing, Roller, PF;B	557	Guide Plate, Cable
527	Crescent Ring	558	Sheet, Cable
528	Plain Washer, 12.2x0.5x15	559	Detector, HP
529	Roller Assembly, Paper Eject	560	Carriage Assembly
530	Bushing, 6	561	Lever, Adjust
531	Retaining Ring, Type-E(4)	562	Grouding Plate, Head
532	Spur Gear, 36	563	Oil Pad
533	Spur Gear, 11	564	Slider, CR
534	Plain Washer, 4.1x0.5x6.5	565	Timing Belt
535	Paper Guide, Front	566	Shaft, CR, Guide
536	Grounding Spring, Paper Eject	567	Pulley Assembly, Driven
537	Guide, Paper Eject	568	Holder, Pulley, Driven;B
538	Frame, Paper Eject	569	Compression Spring, 19.6
539	Holder, Star Wheel, Right	570	Lever, PG
540	Holder, Star Wheel, Left	571	Lever, PG, Sub
541	Holder, Star Wheel, Front	572	Torsion Spring, 63.7
542	Star Wheel Assembly, 8(Natural)	573	Combination Spring, 12.4, 28
543	Star Wheel 8;B	574	Combination Spring, 16, 21.6
544	Bar Spring, Star Wheel	576	Absorber, Slider, Cap
545	Paper Guide, Upper	577	Bushing, Fixing, Combination Gear
546	Paper Guide, Right	578	Push Nut, 2
547	Paper Guide, Left	579	Harness, HP
548	Shaft, Paper Guide, Upper	580	Harness, PE
549	Shaft, Roller, Driven	581	Harness, ASF



Table A-42. Part List for Stylus Color 740 (3/4)

586	CBS-Tite Screw	719	Holder, Edge Guide, Right
587	CBS-Tite Screw, M3x6	720	Compression Spring, 1.17
588	CBS-Tite (P4) Screw, 3x6, F/Zn	721	Tension Spring, 0.62
589	Leaf Spring, 6.2x0.15x11	722	Lever, Paper Return, Right
590	Plain Washer, 6.1x0.5x9.0	723	Tension Spring, 0.294
591	6N, Class 2, M3	724	Roller, LD, Sub
592	Plain Washer, 3x0.3x7	725	Holder, Roller, LD, Sub, Right
595	Holder, Detector, I/C	726	Pad Assy., Left
596	Lever, Detector, I/C, Bk	727	Lever, Pad, Release, Left
597	Lever, Detector, I/C, CL	728	Holder, Edge Guide, Left
598	Grounding Plate, Roller, PF	729	Lever, Paper Return, Left
600	Torsion Spring, 1.08	730	Holder, Roller, LD, Sub, Left
601	Detector, I/C	731	Roller Assy., LD, Left
602	Harness, I/C	732	Roller Assy., LD, Right
700	Printthead	733	Cover, Roller, LD, Left
701	Fastener, Head	734	Cover, Roller, LD, Right
702	Torsion Spring, 49	735	Compression Spring, 1.961
703	CBP-Tite Screw, 3x6, F/Zn	736	Lever, Fixing, Edge Guide;B
704	Cable, Head	737	Tension Spring, 0.088
705	Holder, Cable	738	Shaft, Roller, LD
706	Spacer, Cable Head	739	Lever, Hopper, Release
707	Frame, ASF;B	740	Wheel, Detection
708	Hopper	741	Lever, Brake
709	Edge Guide	742	Pad, Brake
710	Cork	743	Torsion Spring, 41.2
711	Slider, Edge Guide	744	Bushing, Fixing, Shaft
712	Compression Spring, 3.23	745	Sheet, Paper Feed
713	Pad, Brake, Edge Guide	746	Holder, Sheet, Paper Feed
714	Reinforcing Plate, Hopper	747	Shaft, Mouting, CR
716	Pad Assy., Right	748	CBS (P4) Screw, 3x6, F/Zn
717	Lever, Pad, Release, Right	750	Spur Gear, 34
718	Bar Spring, Holder, Pad	751	Paper Guide, Lower

Table A-43. Part Lis for Stylus Color 740 (4/4)









752	Absorber, Waste Ink, Large		
753	Tray, Absorber		
754	Spacer, Tray		
755	Bushing, Fixing, Shaft, Left		
756	Paper Support, Sub, Upper		
757	Holder, Paper Support, Sub, Upper		
758	Torsion Spring, 0.29		
759	Cover, Cartridge, Bk		
760	Cover, Cartridge, C;B		
761	Separator, Cartridge, Bk		
762	Separator, Cartridge, C		
763	Detector, HP		
764	Cork;B		
765	Cleaner, Head, ASP		

## A.6 Circuit Diagrams

---

See the following pages for the circuit diagrams below.

**NOTE:** For circuit diagram for C206MAIN-B, refer to the hard copies, as no pdf files for it is provided.

-  **C206MAIN-B circuit diagram 1/2, 2/2**  
See the hard copies.
-  **C255MAIN circuit diagram**
-  **C256MAIN circuit diagram**
-  **C257MAIN circuit diagram**
-  **C206PSB circuit diagram**
-  **C206PSE circuit diagram**
-  **C257PSB circuit diagram**
-  **C257PSE circuit diagram**
-  **C257PSK circuit diagram**

C206MAIN-B Circuit diagrams 1 of 2  
See the hard copy.

C206MAIN-B Circuit diagrams 2 of 2  
See the hard copy.

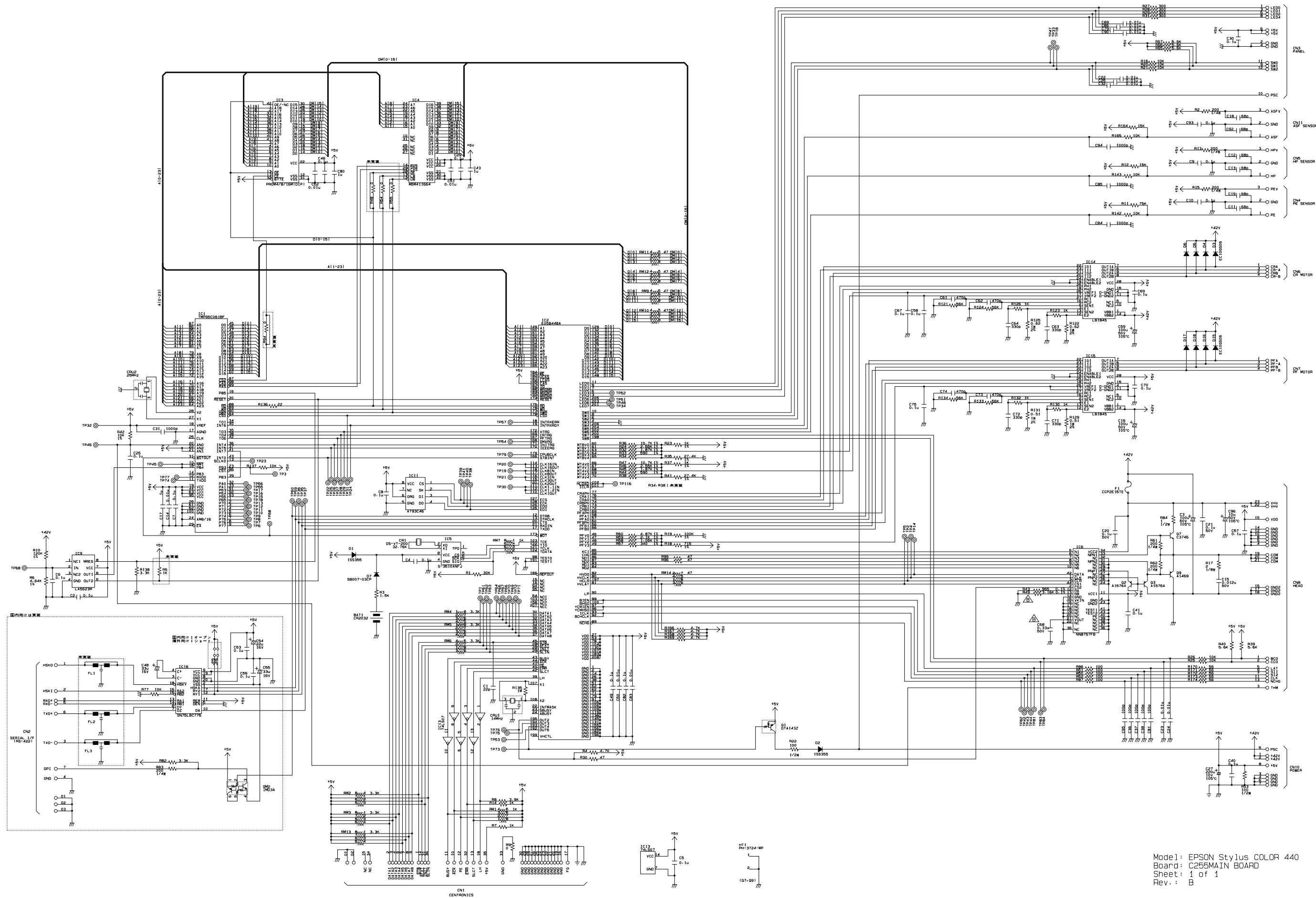

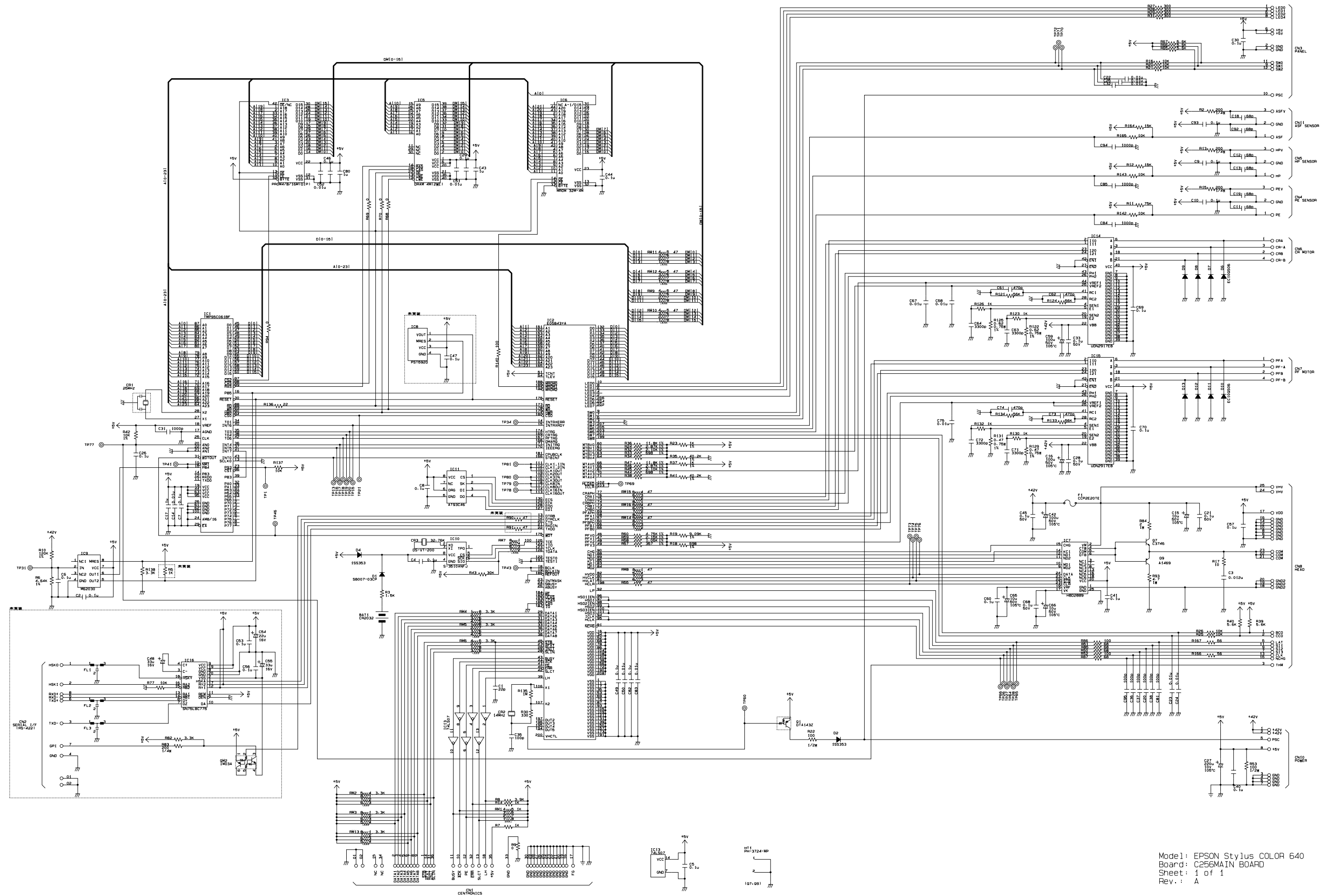

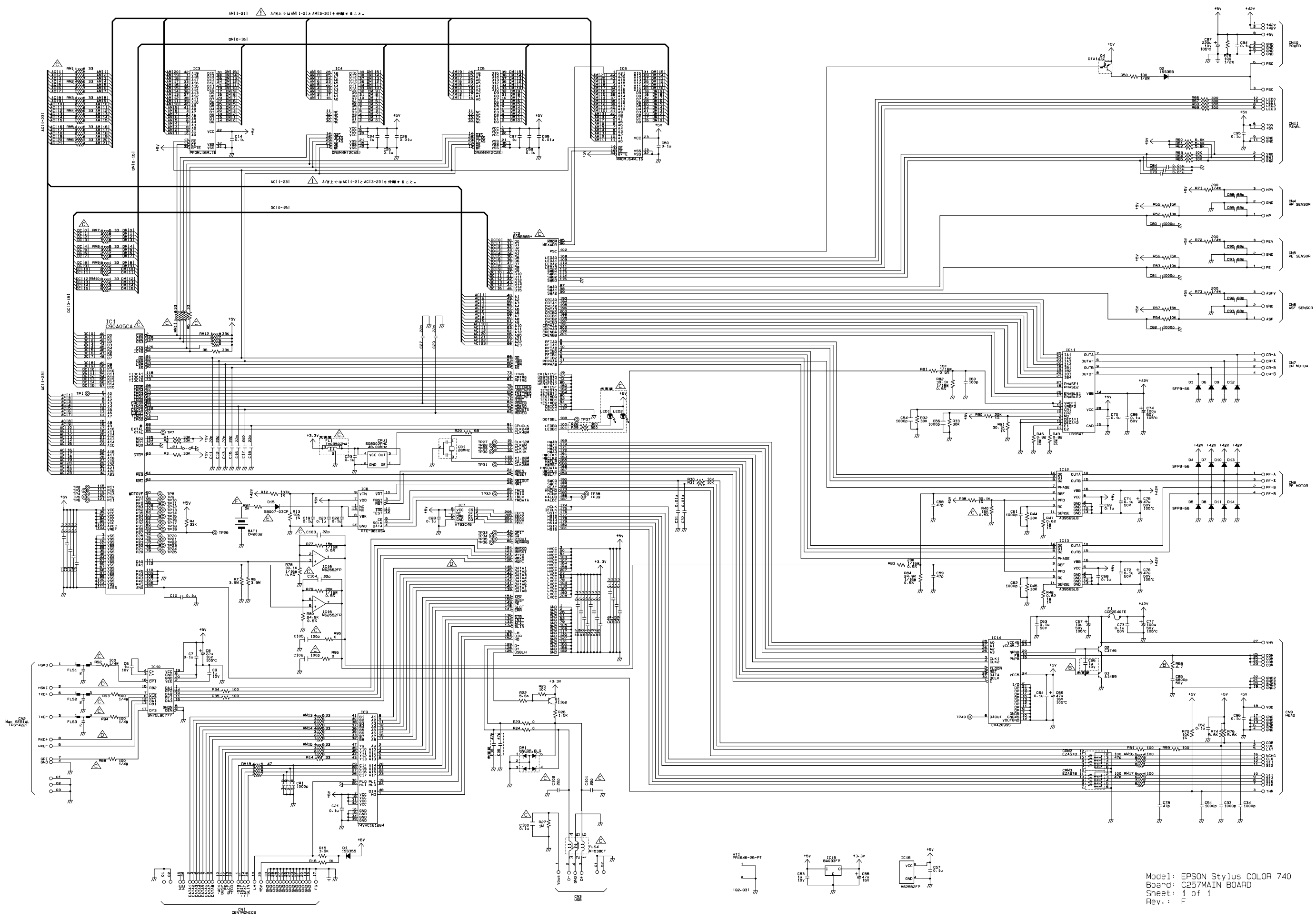

Model: EPSON Stylus COLOR 740  
 Board: C257MAIN BOARD  
 Sheet: 1 of 1  
 Rev.: F

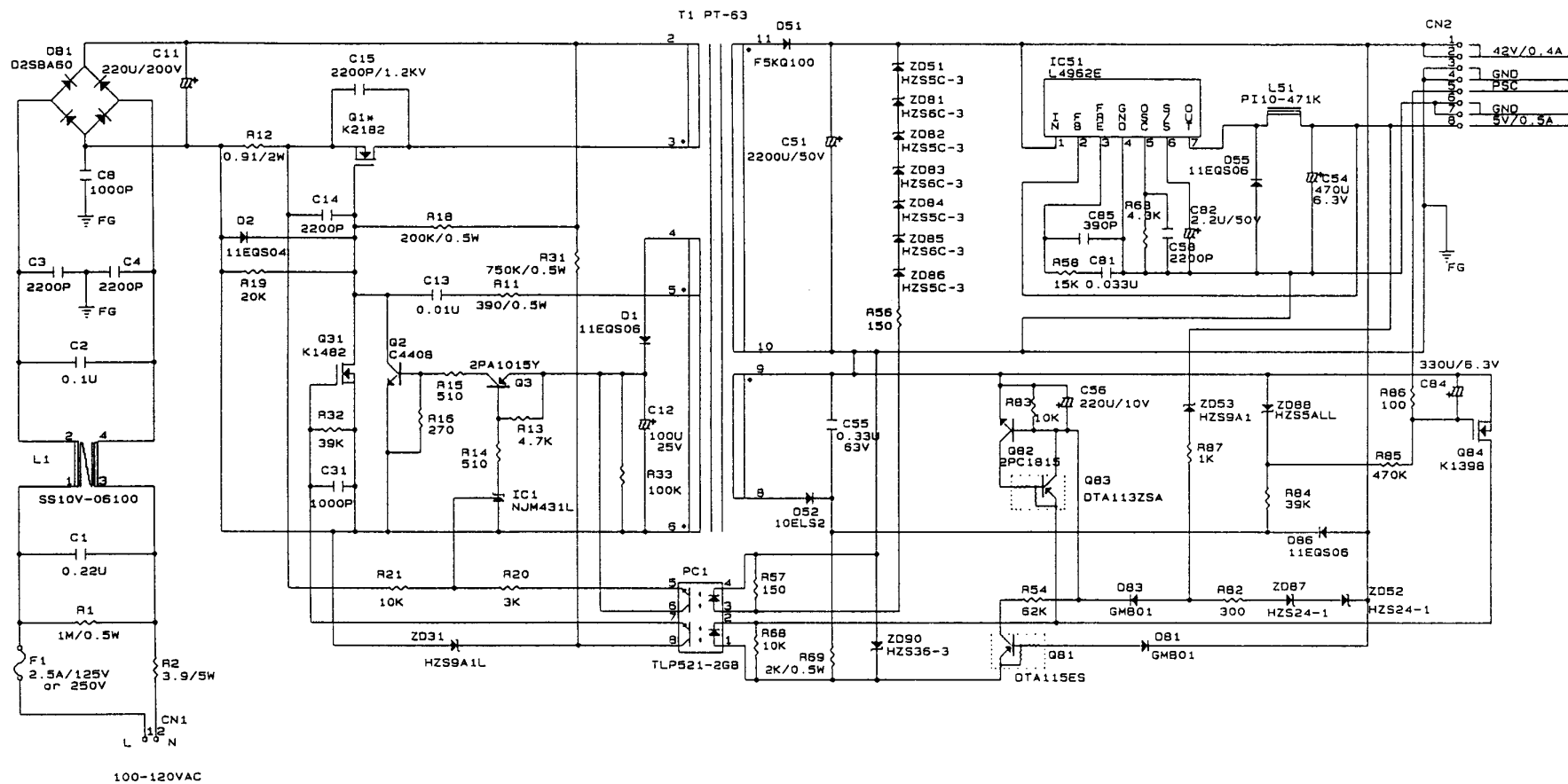

C206PSB 1/1



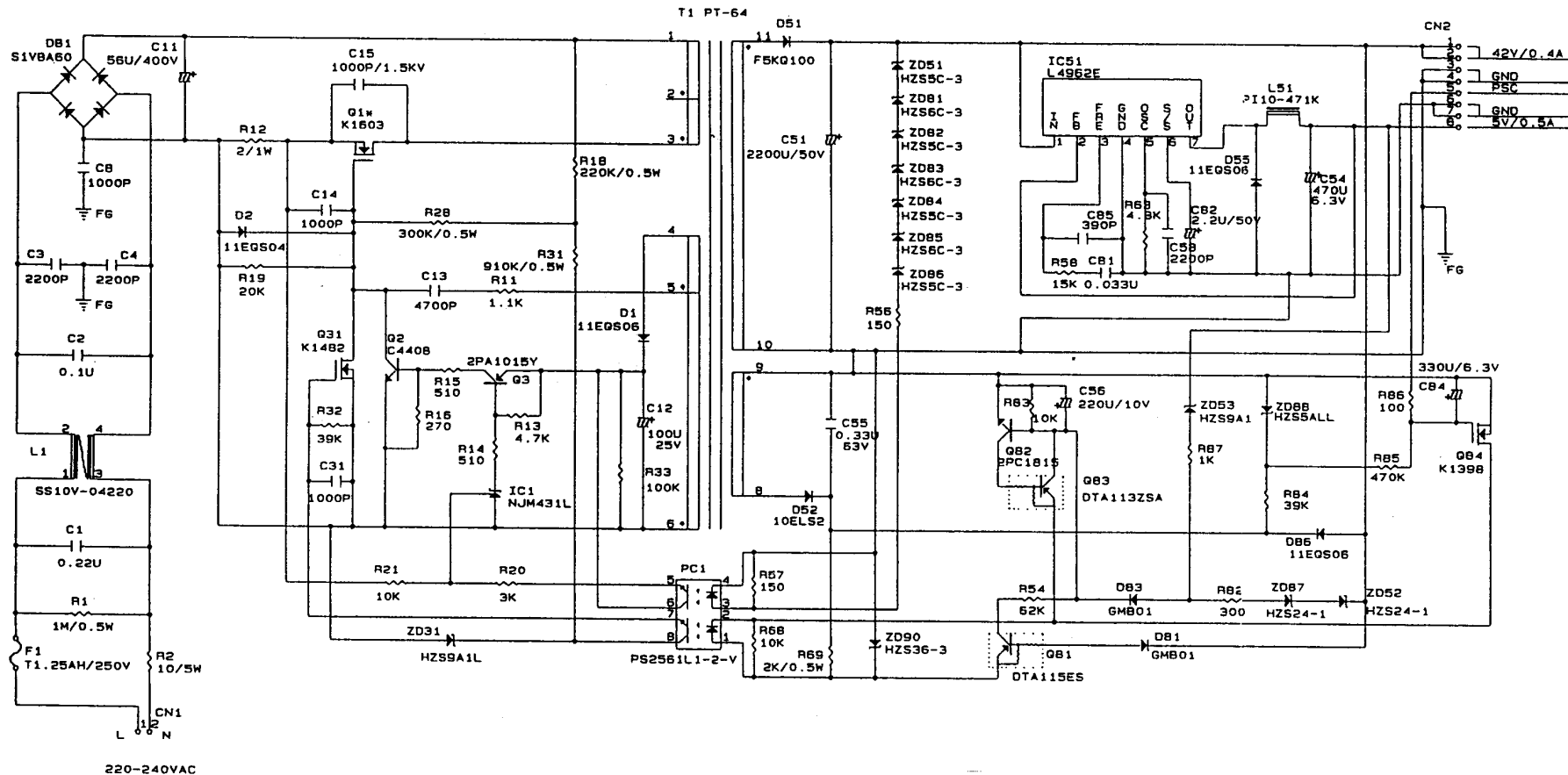

C206PSE 1/1

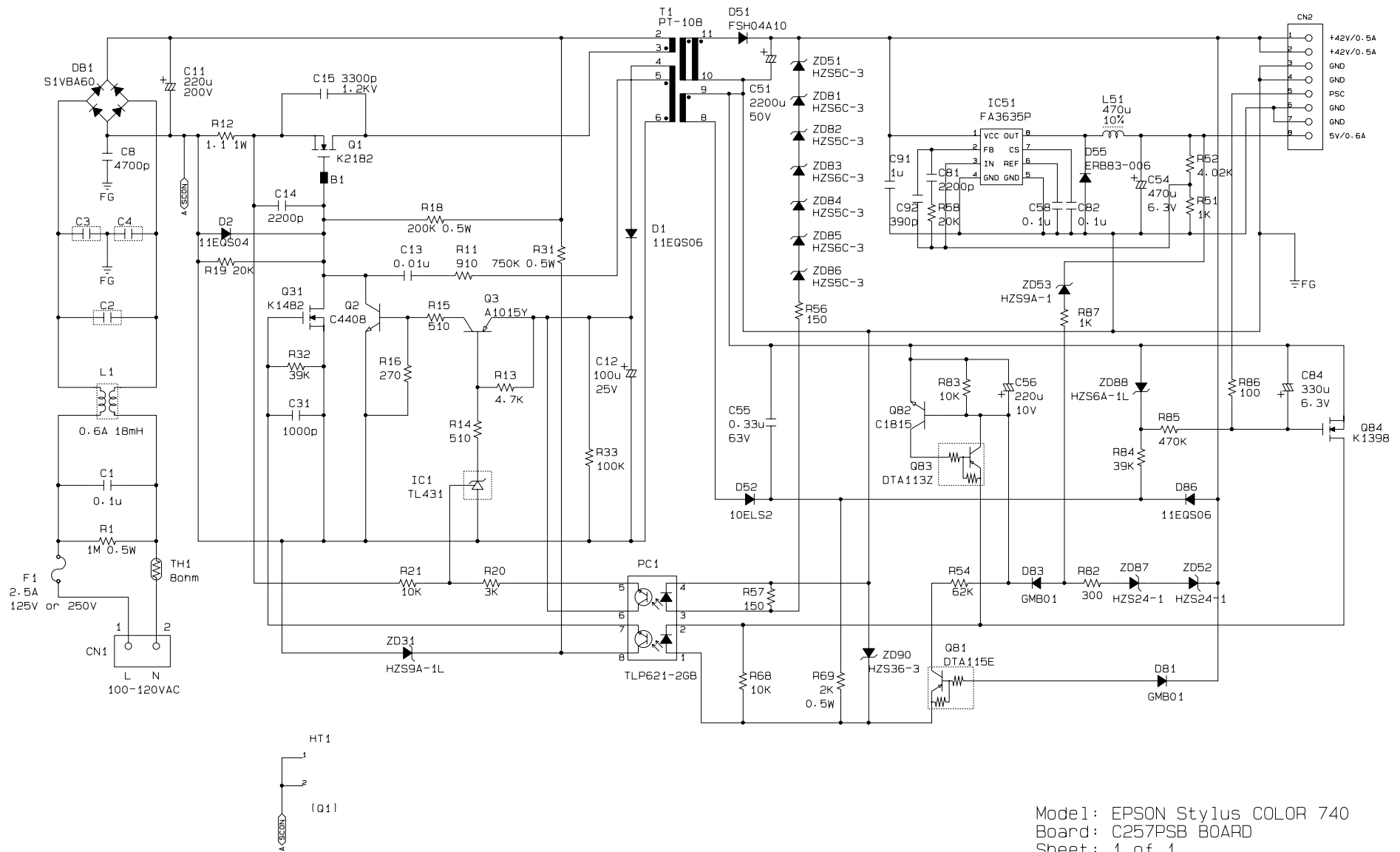

Model: EPSON Stylus COLOR 740  
 Board: C257PSB BOARD  
 Sheet: 1 of 1  
 Rev.: A



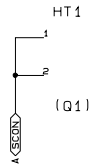
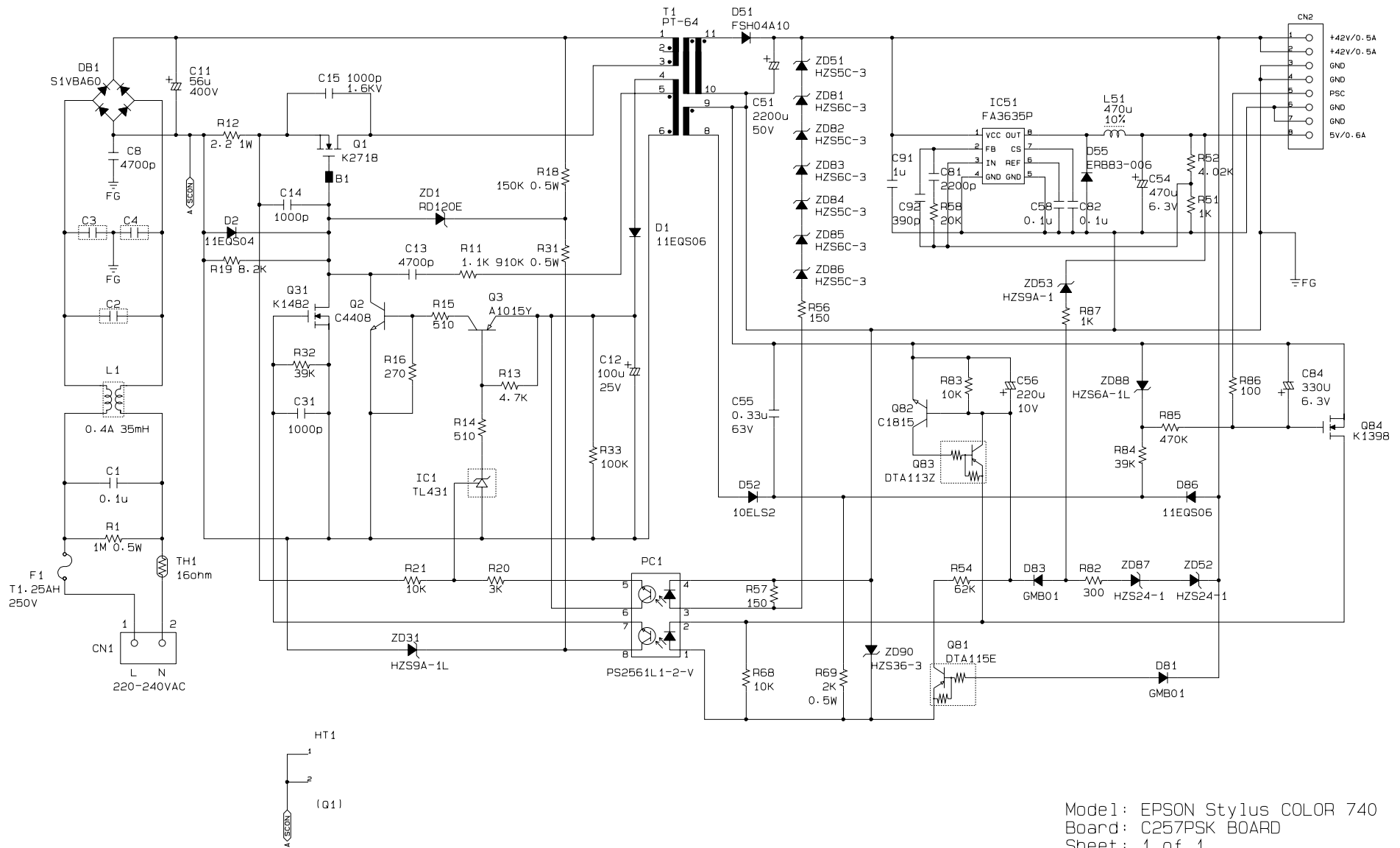

Model: EPSON Stylus COLOR 740  
 Board: C257PSK BOARD  
 Sheet: 1 of 1  
 Rev.: A